



Development of e-Courses for B.Sc.(Agriculture)
Degree Program



GPBR-311
Principles of Plant Biotechnology

Principles Of Plant Biotechnology

Author:- TNAU (ICAR)

Disclaimer:- The information on this website does not warrant or assume any legal liability or responsibility for the accuracy, completeness or usefulness of the courseware contents. The contents are provided free for noncommercial purpose such as teaching, training, research, extension and self learning.



Agriculture Study Material



Online Test, Job Information, Agriculture News

VISIT:- AGRIEXAM.COM

Principles Of Plant Biotechnology

1	Concepts of Biotechnology	1-16
2	Tissue culture and its history	17-29
3	Scope and importance in crop improvement	30-39
4	Totipotency and Morphogenesis	40-56
5	Nutritional requirements	57-70
6	Techniques of in vitro cultures	71-87
7	Micro propagation	88-99
8	Anther and microspore culture	100-110
9	Ovule culture	111-114
10	Ovary and embryo culture	115-124
11	Test tube fertilization	125-128
12	Endosperm culture	129-133
13	Factors influencing morphogenesis	134-137
14	Applications and achievements	138-150
15	Somaclonal variation and crop improvement	151-160
16	Somatic embryogenesis	161-175
17	Protoplast isolation	176-193
18	Products of somatic hybrids and cybrids	194-201
19	Genetic engineering in plants	202-220

20	Enzymes used in Genetic Engineering	221-229
21	Vectors: The carriers of DNA molecules	230-246
22	Gene cloning	247-250
23	Gene delivery methods in plants	251-266
24	Transgenic plants and their applications	267-284
25	Blotting techniques	285-301
26	DNA finger printing	302-309
27	DNA markers in plant genome analysis	310-331
28	QTL mapping	332-339
29	Marker assisted selection and Crop improvement	340-345

Concepts of Biotechnology

The term "Biotechnology" was first coined in 1919 by **Karl Ereky** which means products are produced from raw materials with the aid of living organisms.

Biotechnology is NOT new. Man has been manipulating living things to solve problems and improve his way of life for millennia. Early agriculture concentrated on producing food. Plants and animals were selectively bred and microorganisms were used to make food items such as beverages, cheese and bread. The late eighteenth century and the beginning of the nineteenth century saw the advent of vaccinations, crop rotation involving leguminous crops and animal drawn machinery. The end of the nineteenth century was a milestone of biology. Microorganisms were discovered, Mendel's work on genetics was accomplished and institutes for investigating fermentation and other microbial processes were established by Koch, Pasteur and Lister.

Biotechnology at the beginning of the twentieth century began to bring industry and agriculture together. During World War I, fermentation processes were developed that produced acetone from starch and paint solvents for the rapidly growing automobile industry. Work in the 1930s was geared towards using surplus agricultural products to supply industry instead of imports or petrochemicals. The advent of World War II brought the manufacture of penicillin. The biotechnical focus moved to pharmaceuticals. The "cold war" years were dominated by work with microorganisms in preparation for biological warfare as well as antibiotics and fermentation processes (Goodman, 1987).

Biotechnology is currently being used in many areas including agriculture, bioremediation, food processing and energy production. DNA fingerprinting is becoming a common practice in forensics. Production of insulin and other medicines is accomplished through cloning of vectors that now carry the chosen gene. Immunoassays are used not only in medicine for drug level and pregnancy testing, but also by farmers to aid in detection of unsafe levels of pesticides, herbicides and toxins on crops and in animal products. These assays also provide rapid field tests for industrial chemicals in ground water, sediment and soil. In agriculture, genetic engineering is being used to produce plants that are resistant to insects, weeds and plant diseases.

Definition

Biotechnology- Bio means life and technology means the application of knowledge for practical use *ie.*, the use of living organisms to make or improve a product.

Other definitions for the term Biotechnology

- The use of living organisms to solve problems or make useful products.
- The use of cells and biological molecules to solve problems or make useful products. Biological molecules include DNA, RNA and proteins.
- The commercial application of living organisms or their products, which involves the deliberate manipulation of their DNA molecules.
- Make a living cell to perform a specific task in a predictable and controllable way.

Biotechnology has been described as "Janus-faced". This implies that there are two sides. On one side techniques allow DNA to be manipulated to move genes from one organism to another. On the other, it involves relatively new technologies whose consequences are untested and should be met with caution.

Stages of biotechnology development

- ✓ Ancient biotechnology - 8000-4000 B.C
Early history as related to food and shelter; includes domestication
- ✓ Classical biotechnology - 2000 B.C.; 1800-1900 AD
Built on ancient biotechnology; fermentation promoted food production and medicine
- ✓ 1900-1953: Genetics
- ✓ 1953 - 1976: DNA research, science explodes
- ✓ Modern biotechnology - 1977
Manipulates genetic information in organism; Genetic engineering

Biotechnology is a collection of various technologies that enable us to improve crop yield and food quality in agriculture and to produce a broader array of products in industries.

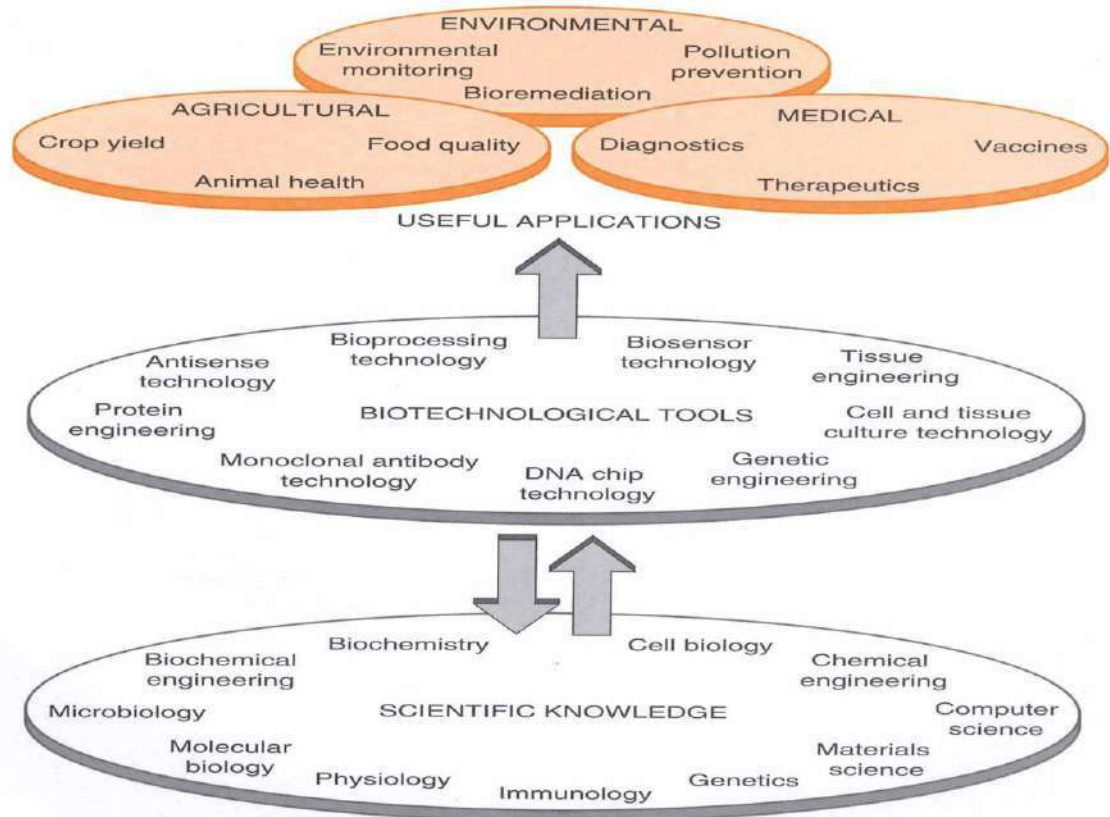

Synthesis of scientific and technical knowledge from many academic disciplines has produced the set of enabling technologies we call biotechnology. Any one technology will be applied to a number of industries to produce an even broader array of products.

Various technologies and their uses

- Genetic Engineering (Recombinant DNA) Technology
The use of cellular enzymes to manipulate DNA
Transferring DNA between unrelated organisms
- Protein Engineering Technology
Improve existing/create novel proteins to make useful products
- Antisense or RNAi Technology
Block or decrease the production of certain proteins
- Cell and Tissue Culture Technology
Grow cells/tissues under laboratory conditions to produce an entire organism, or to produce new products
- Bioinformatics Technology
Computational analysis of biological data, e.g., sequence analysis macromolecular structures, high-throughput profiling data analysis
- Functional Genomics (the -omics)

The use of genome-wide, high-throughput approaches to determine the biological function of all of the genes and their products

High-throughput technologies (the -omics)

- Transcriptomics (e.g. microarray expression profiling)
- Proteomics (e.g. structures/modifications/interactions of proteins)

Proteins are responsible for an endless number of tasks within the cell. The complete set of proteins in a cell can be referred to as its *proteome* and the study of protein structure and function and what every protein in the cell is doing is known as *proteomics*. The proteome is highly dynamic and it changes from time to time in response to different environmental stimuli. The goal of *proteomics* is to understand how the structure and function of proteins allow them to do what they do, what they interact with and how they contribute to life processes.

- Metabolomics (e.g. metabolite profiling, chemical fingerprinting, flux analysis)
Metabolomics is one of the newest 'omics' sciences. The *metabolome* refers to the complete set of low molecular weight compounds in a sample. These compounds are the substrates and by products of enzymatic reactions and have a direct effect on the phenotype of the cell. Thus, metabolomics aims at determining a sample's profile of these compounds at a specified time under specific environmental conditions
- Transgenomics (e.g. knock-out, knock-in, gene tagging, mutagenesis)
- Translational genomics

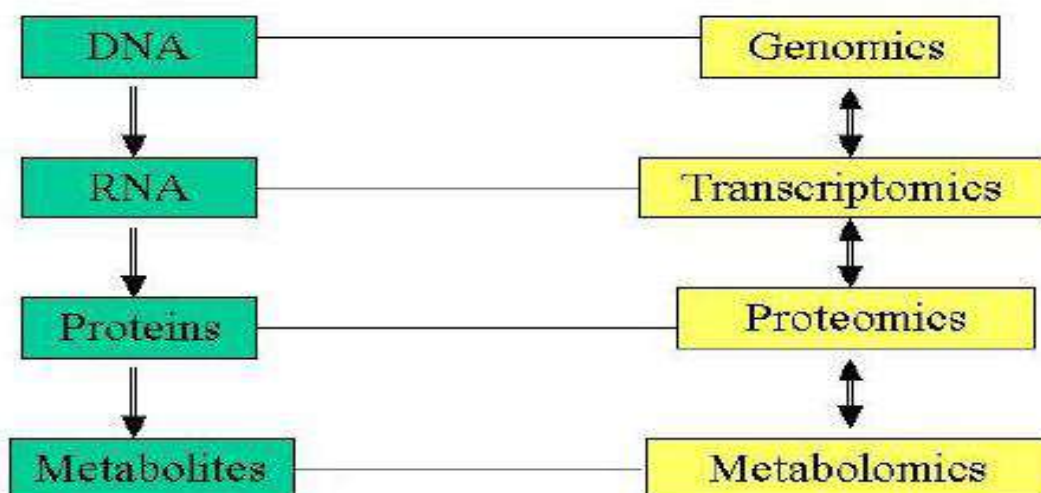

Applications of biotechnology & genomics

1. Environmental biotechnology

A. Environmental monitoring

- Diagnosis of environmental problems via biotechnology

B. Waste management

- Bioremediation: the use of microbes to break down organic molecules or environmental pollutants.

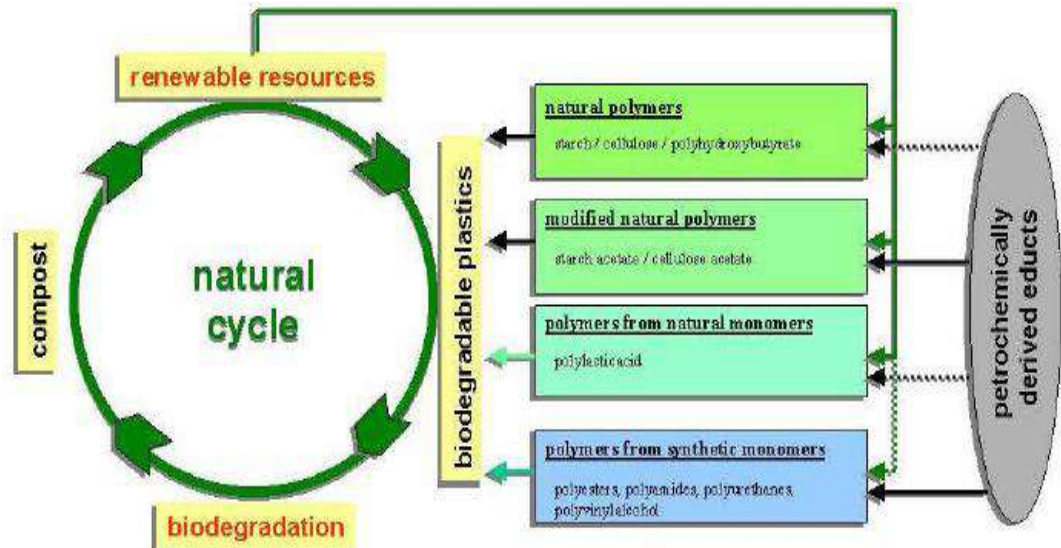

- Phyto remediation: the use of plants to remove pollutants (e.g. heavy metals) from the environment.

C. Pollution prevention

- Renewable resources
- Biodegradable products
- Alternative energy sources

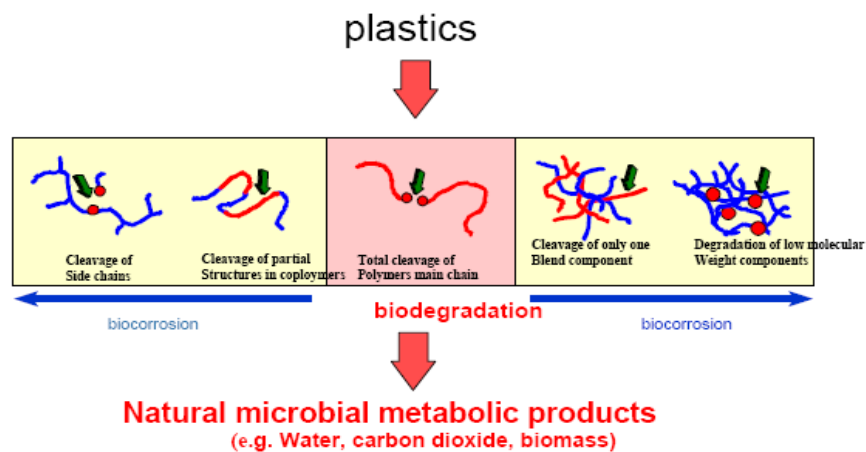

2. Medical biotechnology

- A. Diagnostics
- B. Therapeutics
- C. Vaccines
- D. Medical research tools
- E. Human Genome Research

3. Agricultural biotechnology

- A. Animal Biotechnology
- B. Crop Biotechnology
- C. Horticultural Biotechnology
- D. Tree Biotechnology
- E. Food processing

4. Evolutionary and ecological genomics

Finding genes associated with ecological traits and evolutionary diversification.
Common goals: health, productivity

Plant biotechnology /Agricultural biotechnology

A process to produce a genetically modified plant by removing genetic information from an organism, manipulating it in the laboratory and then transferring it into a plant to change certain of its characteristics . In Nutshell it's the manipulation of plants for the benefit of mankind

The plants are mainly manipulated for two major objectives

A. Crop improvement

- Herbicide tolerance (in use)
- Pest resistance (in use)
- Drought tolerance
- Nitrogen fixing ability
- Acidity and Salinity tolerance

B. Nutritional value of crops

- Improving food quality and safety
- Healthier cooking oils by decreasing the conc. of saturated fatty acids in vegetable oils
- Functional foods: foods containing significant levels of biologically active components that impart health benefits

Various technologies applied in plant biotechnology includes

- Genetic engineering/ recombinant DNA technology
- Tissue culture
- Molecular breeding – MAS

Traditional plant breeding involves cross-breeding of similar plants to produce new varieties with different traits. But it takes many generations to achieve desired result. By using various biotechnological tools, crop improvement can be achieved faster and it even facilitates to transfer genes from unrelated species

Genetic engineering

Manipulation of genes is called genetic engineering or recombinant DNA technology. It removes gene(s) from one organism and either

- Transfers them to another
- Puts them back in the original with a different combination

Various gene transfer techniques used in genetic engineering includes

- Agrobacterium mediated gene transfer: Desired trait is isolated from DNA of original organism, inserted into *Agrobacterium*, target plant is infected. Cells that accept the DNA are grown into plants with the new trait.
- Gene gun: DNA that codes for the desired trait is coated onto tiny particles of tungsten and fired into a group of plant cells. Cells that accept the DNA are grown into plants with the desired trait.

Tissue culture

Tissue culture manipulates cells, anthers, pollen grains, or other tissues; so they live for extended periods under laboratory conditions or become whole, living, growing organisms; genetically engineered cells may be converted into genetically engineered organisms through tissue culture.

Marker Assisted Selection

Marker-aided genetic analysis studies DNA sequences to identify genes, QTLs (quantitative trait loci), and other molecular markers and to associate them with organism functions, i.e., gene identification. Marker-aided selection is the identification and inheritance tracing of previously identified DNA fragments through a series of generations.

Applications of biotechnology in agriculture (plants)

A. Crop Improvement

- Plants with built in resistance to pest and Diseases.
- Plants with built in tolerance to environmental conditions
- Improved color and quality

B. Pharmaceuticals

- Plants that produce edible vaccines

C. Food

- Improved taste and nutrition
- Improved handling qualities

D. Industrial

- plants that produce plastics, fuels, and other products
- plants for environmental cleanup

E. Other

- pesticides made from naturally-occurring microorganisms and insects

Applications of biotechnology in agriculture (animals)

A. Food

- Increased milk production

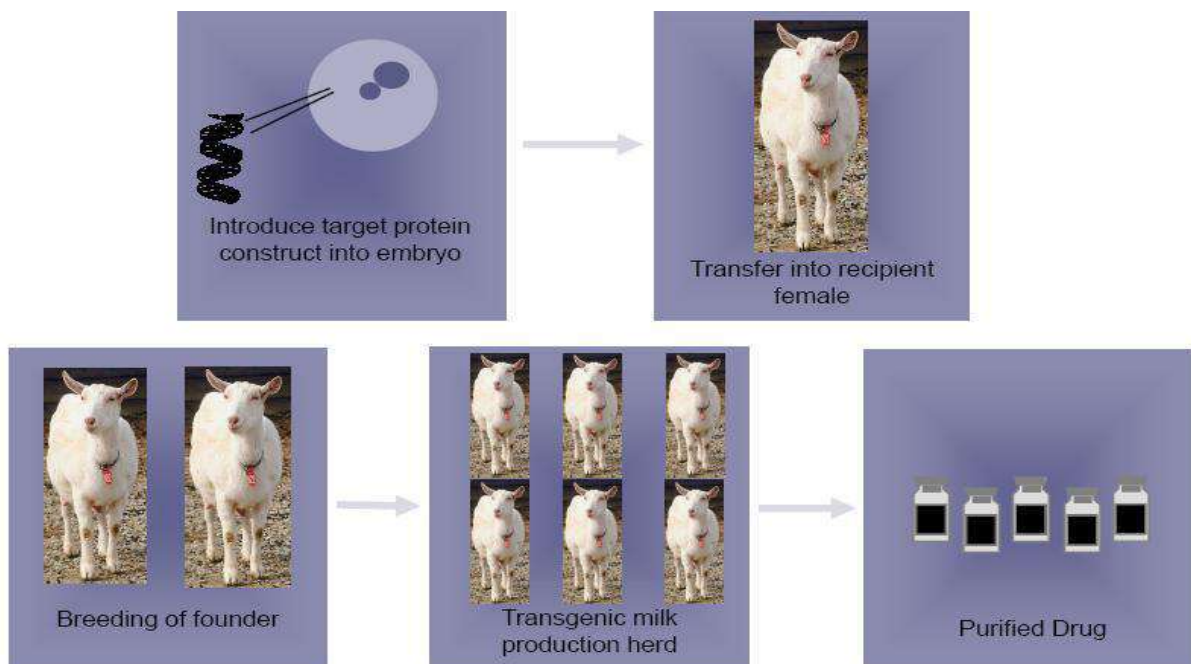

- leaner meat in pork
- growth hormones in farm-raised fish that result in earlier market-ready fish

B. Pharmaceuticals

- Animals engineered to produce human proteins for drugs, including insulin and vaccines

C. Breeding

- Disease tolerance
- Exact copies of desired stock
- Increased yields

D. Health

- Microorganisms introduced into feed for beneficial purposes
- Diagnostics for disease and pregnancy detection
- Animals engineered to produce organs suitable for transplantation into humans

History of biotechnology

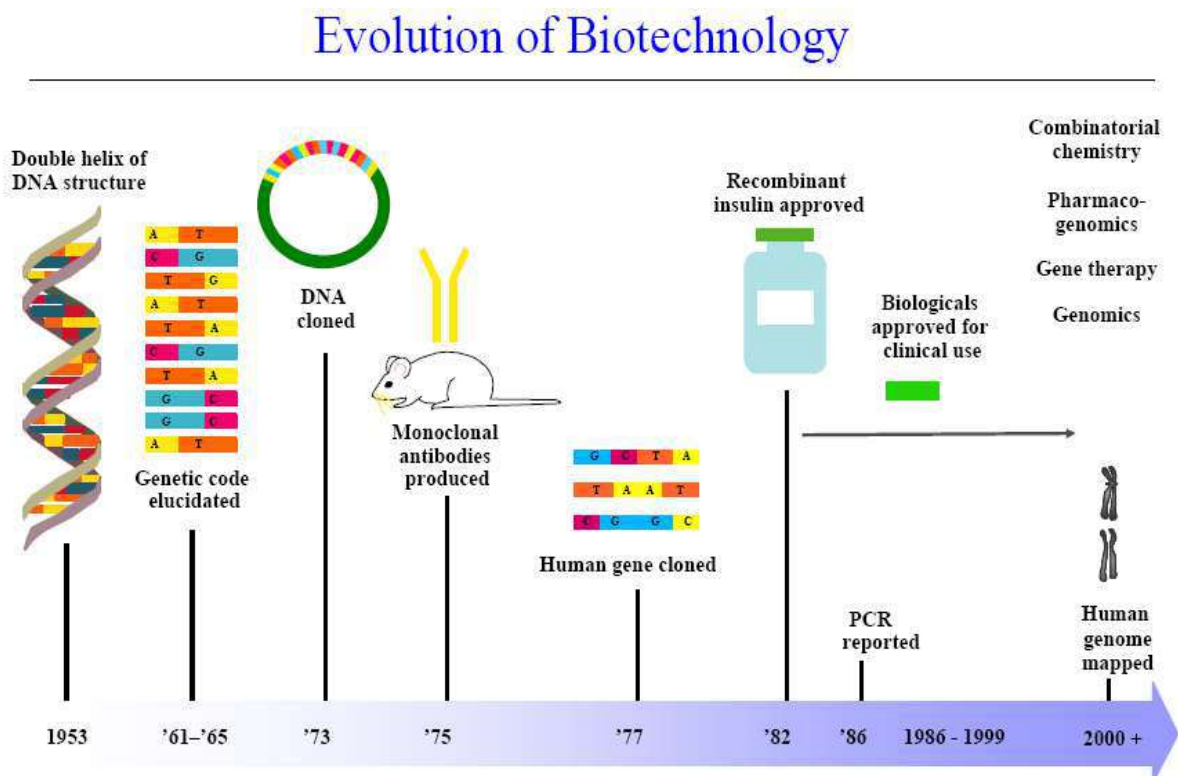

1797: First vaccination. Edward Jenner takes pus from a cowpox lesion, inserts it into an incision on a boy's arm.

1830: Proteins are discovered.

1833: First enzyme is discovered and isolated

1865: Gregor Mendel discovers the laws of inheritance by studying flowers in his garden. The science of genetics begins.

1915: Phages — viruses that only infect bacteria — are discovered

1927: Herman Muller discovers that radiation causes defects in chromosomes.

1944: DNA is proven to carry genetic information by Oswald Avery, Colin MacLeod and Maclyn McCarty.

1953: James Watson and Francis Crick describe the double helical structure of DNA. They shared the 1962 Nobel Prize in Medicine or Physiology with Maurice Wilkins.

1955: The amino acid sequence of insulin is discovered by Frederick Sanger.

1958: DNA is made in a test tube for the first time. Sickle cell disease is shown to occur due to a change in one amino acid

1971: The first complete synthesis of a gene occurs. Discovery of *restriction enzymes* that cut and splice genetic material very specifically occurs. This opens the way for gene cloning.

1973: Stanley Cohen and Herbert Boyer perfect genetic engineering techniques to cut and paste DNA using restriction enzymes.

1975: Georges Kohler and Cesar Milstein develop the technology to produce monoclonal antibodies — highly specific, purified antibodies derived from only one clone of cells that recognize only one antigen. They shared the

1984: Nobel Prize in Physiology or Medicine with Neils Jerne.

1981: The first transgenic animals are produced by transferring genes from other animals into mice.

1983: The polymerase chain reaction (PCR) technique, which makes unlimited copies of genes and gene fragments, is conceived. Kary Mullis, who was born in Lenoir, N.C., wins the 1993 Nobel Prize in Chemistry for the discovery.

1986: First recombinant vaccine is approved for human use: hepatitis B. First anti-cancer drug is produced through biotech: interferon.

1987: First approval for field tests of a genetically modified food plant: virus-resistant tomatoes.

1994: Genetically modified tomatoes are sold in the U.S. for the first time.

1990: The Human Genome Project — an international effort to map all of the genes in the human genome — is launched.

2002: The draft version of the human genome is published.

1997: Scientists report the birth of Dolly, the first animal cloned from an adult cell.

1998: Human embryonic stem cell lines are established. They offer hope to many because they may be able to replace diseased or dysfunctional cells.

2003: The SARS (severe acute respiratory syndrome) virus is sequenced three weeks after its discovery.

2004: The first cloned pet — a kitten — is delivered to its owner. She is called CopyCat (or Cc for short).

2006: A recombinant vaccine against human papillomavirus (HPV) receives FDA approval. The virus causes genital warts and can cause cervical cancer.

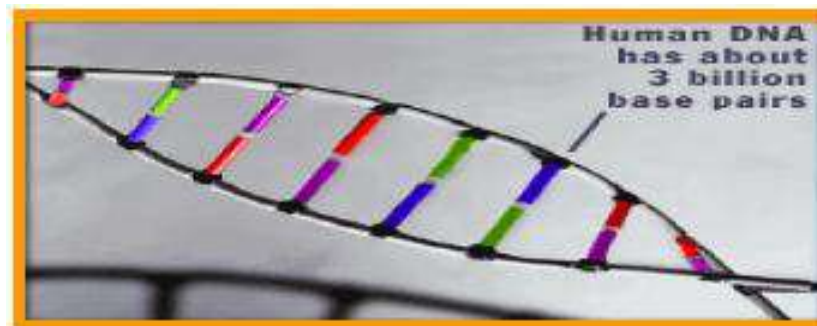

Source:

<http://www.woodrow.org/teachers/bi/1993/intro.html>

<http://www.biotechno.netfirms.com/Biotechnology.htm>

http://en.wikipedia.org/wiki/Genetic_engineering

http://en.wikipedia.org/wiki/Marker_assisted_selection

Questions

1. The term "Biotechnology" was first coined in
a) **1919** b) 1916 c) 1991 d) 1961
2. The term "Biotechnology" was first coined by
a) Neuberg b) Lipmann c) Frederick Sanger's d) **Karl Ereky**
3. Biotechnology is used in areas including
a) Agriculture b) Bioremediation c) Food processing d) **All the above**
4. In agriculture, genetic engineering is being used to produce plants that are resistant to
a) insects b) weeds c) plant diseases d) **All the above**
5. Immunoassays are used for
a) drug level testing b) detection of unsafe levels of pesticides, herbicides and toxins on crops and in animal products
c) **both a and b** d) None of the above
6. Genetic engineering is
a) **use of cellular enzymes to manipulate DNA** b) Improve existing/create novel proteins to make useful products
c) Block or decrease the production of certain proteins d) Grow cells/tissues under laboratory conditions to produce an entire organism, or to produce new products
7. Protein engineering is
a) use of cellular enzymes to manipulate DNA b) **Improve existing/create novel proteins to make useful products**
c) Block or decrease the production of certain proteins d) Grow cells/tissues under laboratory conditions to produce an entire organism, or to produce new products
8. Antisense or RNAi technology is

- a) use of cellular enzymes to manipulate DNA
- b) Improve existing/create novel proteins to make useful products
- c) **Block or decrease the production of certain proteins**
- d) Grow cells/tissues under laboratory conditions to produce an entire organism, or to produce new products

9. Cell and tissue culture technology is

- a) use of cellular enzymes to manipulate DNA
- b) Improve existing/create novel proteins to make useful products
- c) Block or decrease the production of certain proteins
- d) **Grow cells/tissues under laboratory conditions to produce an entire organism, or to produce new products**

10. Bioinformatics technology is

- a) use of cellular enzymes to manipulate DNA
- b) Improve existing/create novel proteins to make useful products
- c) Block or decrease the production of certain proteins
- d) **Computational analysis of biological data**

11. Functional Genomics

- a) **High-throughput approaches to determine the biological function of all of the genes and their products**
- b) Improve existing/create novel proteins to make useful products
- c) Block or decrease the production of certain proteins
- d) Computational analysis of biological data

12. Translational genomics include(s).....

- a) Transcriptomics alone
- b) Proteomics alone
- c) Metabolomics and Transgenomics
- d) **All the above**

13. Metabolomics include(s)

- a) Metabolite profiling
- b) Chemical fingerprinting
- c) Flux analysis
- d) **All the above**

14. Various technologies applied in plant biotechnology includes

- a) Genetic engineering/ recombinant DNA technology b) Tissue culture
 c) Molecular breeding - MAS **d) All the above**
15. Vaccination was first attempted by
- a) Gregor Mendel b) Oswald Avery
 c) Colin MacLeod **d) Edward Jenner**
16. Vaccination was first attempted in the year.....
- a) 1797** b) 1777
 c) 1787 d) 1767
17. Laws of inheritance was discovered by
- a) Gregor Mendel** b) Oswald Avery
 c) Colin MacLeod d) Edward Jenner
18. The science of genetics was born in the year.....
- a) 1865** b) 1856
 c) 1855 d) 1846
19. Phages infect
- a) Only bacteria** b) Only viruse
 c) Both a & b d) None of the above
20. Name the scientist who discovered that radiation causes defects in chromosomes

- a) Gregor Mendel b) Oswald Avery
 c) Colin MacLeod **d) Herman Muller**
21. DNA is proven to carry genetic information by.....
- a) Oswald Avery b) Colin MacLeod
 c) Maclyn McCarty **d) All the above**
22. DNA is proven to carry genetic information in the year

- a) 1944
- c) 1948

- b) 1946
- d) None of the above

23. Double helical structure of DNA is described by

- a) James Watson
- c) **Both**

- b) Francis Crick
- d) None of the above

24. The amino acid sequence of insulin is discovered by

- a) James Watson
- c) **Frederick Sanger**

- b) Francis Crick
- d) None of the above

25. Sickle cell disease occurs due to a change inamino acid(s).

- a) **One**
- c) Three

- b) Two
- d) None of the above

26. The first complete synthesis of a gene occurred in the

- a) 1917
- c) 1791

- b) **1971**
- d) None of the above

27. Genetic engineering technique, to cut and paste DNA using restriction enzymes is perfected by

- a) Stanley Cohen
- c) **Both**

- b) Herbert Boyer
- d) None of the above

28. The technology to produce monoclonal antibodies is developed by

- a) Georges Kohler
- c) **Both**

- b) Cesar Milstein
- d) None of the above

29. developed the polymerase chain reaction (PCR) technique.

- a) **Kary Mullis**
- c) Cesar Milstein

- b) Georges Kohler
- d) None of the above

30. First recombinant vaccine approved for human use is

- a) **hepatitis B**

- b) polio

c) hepatitis C

d) None of the above

31. is the first genetically modified plant approved for field tests.

a) virus-resistant tomatoes

b) virus-resistant brinjal

c) virus-resistant cotton

d) None of the above

32. Genetically modified tomatoes are sold in the U.S. for the first time in the year

a) 1994

b) 1971

c) 1991

d) None of the above

33. The Human Genome Project is launched in

a) 1990

b) 1991

c) 2000

d) None of the above

34. The draft version of the human genome is published in

a) 1990

b) 2000

c) 2002

d) 2004

Tissue culture and its history

Plant tissue culture broadly refers to the cultivation *in vitro* of all plant parts, whether a single cell, a tissue or organ under aseptic conditions. Recent progress in the field of plant tissue culture made this area as one of the most dynamic and promising experimental biology.

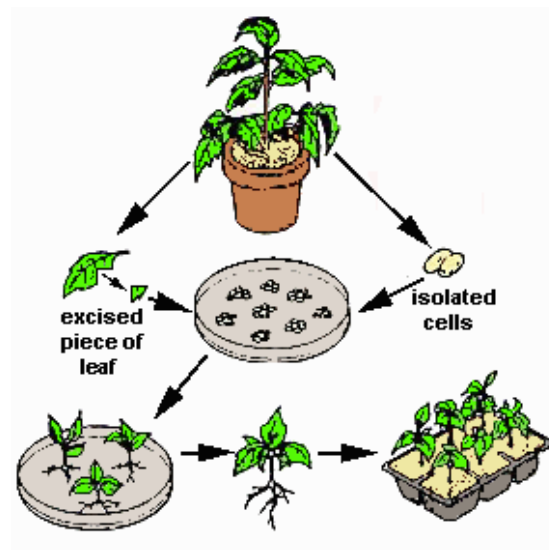

Overview of tissue culture process

This new technique has enabled us to increase the knowledge in the following field of studies.

- Totipotency, nutrition, metabolism, division, differentiation and preservation of plant cells.
- Morphogenesis and plant regeneration from individual cells or tissues through the process namely organogenesis or somatic embryogenesis.
- Variations generated through *in vitro* culture.
- Evolution of haploids through anther and pollen culture including ovule culture.
- Wide hybridization programmes through ovule, ovary and embryo cultures to overcome both pre zygotic and post zygotic sterility mechanisms
- Micropropagation of plant materials
- *In vitro* selection of mutants tolerant to biotic and abiotic stresses.
- *In vitro* culture and secondary metabolite biosynthesis.
- Plant genetic engineering through *in vitro* culture methods and DNA transfer technique.

Thus plant cell, tissue and organ culture permeates plant biotechnology and cements together its various aspects like Physiology, Biochemistry, Genetics and Cell Biology.

Like other subjects, plant cell and tissue culture has its own origin and development. The chronology of major events in this field is presented for the benefit of the new entrants into this field.

1756- Duharmel du Monceau H. L discovered callus formation from the decorticated elm tree. This very old work was foreword for the discovery of plant tissue culture.

1839- Schwann, T.H expressed the view that each living cell of a multicellular organism would be capable of developing independently if provided with proper external conditions.

1853- Trecul. A performed experiment on callus formation by decorticated trees such as *Robinia*, *Pawlonia* and *Ulmus*.

1878- Vochting. H obtained very luxuriant callus from *Brassica rapa* and proposed the polarity in development of buds from the upper portion and roots or callus and from the lower portion of a stem piece.

1885- Roux, W.Z made the first experimental step in tissue culture when he removed a fragment of the neural plate of a chick embryo and cultivated in warm salt solution.

1893- Reching, C described callus formation on isolated stem fragments and root slices.

1901- Morgan, T.H coined the term totipotency to describe the capability of a cell to form an individual plant.

1902- Haberlandt, G – Father of plant tissue culture published a paper on "Experiments on the culture of isolated plant cells: In that he says "I should like to point out the fact that, in my cultures, despite the conspicuous growth of the cells which frequently occurred, cell division was never observed. It will be the problem of future culture experiments to discover the condition under which isolated cells undergo division". He clearly set forth the purposes and potentialities of cell culture after having attempted and failed in the culture of isolated plant cells. The reasons for his failure may be (i) use of three monocotyledonous genera for much of his work, (ii) culture of mature differentiated green mesophyll and pallisade tissues, (iii) contamination during culture growth.



Haberlandt, G – Father of plant tissue culture

1907- Harrison, R.G devised methods of cultivating fragments of living nerve.

1910- Carrel, A was the first scientist who demonstrated the culture of living cells outside the body of an organism.

1922- Kotte, W succeeded in cultivating small root tips of pea and maize in various nutrients. The roots developed well and their growth was maintained for long periods but no subculture was attempted.

1922- Robbins, W.J started cultivation of excised root tips and stem tips of maize under sterile conditions; however, the cultures did not survive independently.

1925- Liabach, F demonstrated the most important application of the embryo culture by crossing *Linum perenne* with *L. austriacum* to get hybrid plants from shriveled seeds.

1934- Gautheret, R.J made preliminary attempts with liquid medium for cultivating plant tissues but failed completely. Later he cultured the explants on medium solidified with agar, and got healthy calli from the explants.

1934- White, P.R obtained indefinite survival of cultured tomato roots on sub culturing in liquid medium.

1939- White, P.R., Gautheret, R.J. and Nobecourt, P simultaneously announced the possibility of cultivating plant tissues for unlimited periods.

1941- Van Overbeek, J., Conklin, M.E. and Blackeslee, A.F established importance of coconut milk for growth and development of very young *Datura* embryos.

1942- White, P.R. and Braun, A.C initiated studies on crown gall and tumour formation in plants.

1944- Skoog, F started his work on organogenesis in tobacco callus.

1946- Ball, E.A showed development of plantlets from sterile cultures of stem tips in *Tropaeolum* and *Lupinus*. He is considered as father of micropropagation.

1947- La Rue C.D initiated endosperm cultures of *Zea mays* and obtained subcultures.

1948- Skoog, F. and Tsui, C studied the chemical control of growth and bud formation in tobacco stem segments and callus cultured *in vitro* and suggested that callus induction and shoot initiation can be regulated by making manipulations in the culture medium.

1949- Street, H.E. and Dormer, K.J initiated work on root culture and its nutrient requirements.

1951- Morel, G. and Wetmore, R.H got successful culture from monocots, once considered as recalcitrants to the cultural conditions.

1952- Steward, F.C., Caplin, S.M. and Miller, F. K discovered the synergistic action of 2, 4-D and coconut milk in a culture of potato tissue.

1952- Morel, G. and Martin, C were the first to demonstrate that virus free plants can be recovered from infected plants through shoot meristem culture.

1953- Muir, W.H found out the cultural conditions favouring the isolation and growth of single cells from higher plants *in vitro* and established nurse culture technique.

1954- Muir, W.H. Hildebrandt A.C. and Riker. A.J obtained the first suspension cultures by transferring callus fragments to agitated liquid medium

1955- Miller, C.O., Skoog, F., Von Saltza, M. and Strong, F.M identified a cell division factor viz., 6-furfualamino purine commonly called kinetin.

1957- Skoog, F. and Miller, C.O advanced the hypothesis that shoot and root initiation in cultured callus can be regulated by particular ratios of auxins and cytokinin.

1957- Skoog, F. and Miller, C.O discovered and introduced the idea of synergistic effects of auxins and cytokinins in promoting cell division in tobacco.

1958- Steward, F.C., Mapes, M.O. and Mears, K observed the phenomenon of somatic embryogenesis in suspension culture of carrot. They also reported that cells in suspension derived from explanted roots of cultivated carrots were capable of forming unorganised cell clusters, which in turn could yield first roots, then shoots and ultimately whole plants.

1959- Reinert, J observed the somatic embryo formation from callus cultures of carrot grown on an agarified medium.

1959- Melchers, G. and Bergmann L were first to culture haploid tissues other than pollen.

1960- Cocking, E.C discovered the technique of isolation and culture of protoplasts after digesting the cell walls enzymatically and demonstrated new cell wall regeneration on protoplasts from tomato fruit locule tissue.

1960- Bergmann L was first to obtain callus by plating cells from suspension cultures on to solid medium. This plating involved mixing cells with warm sugar medium just prior to gelation in petridish (Bergmann plating technique)

1960- Morel, G discovered a technique to produce virus free progenies by meristem culture in *Cymbidium*.

1964- Guha, S. and Maheshwari, S.C cultured mature anthers of *Datura innoxia* to study the physiology of meiosis and accidentally noticed the development of embryoids from the anthers plated on basal medium supplemented with kinetin and coconut milk.

1965- Vasil, V. and Hildebrandt, A.C described rearing of a mature tobacco plant from a single cell grown initially in microculture.

1966- Torrey, J.G advanced the hypothesis that organogenesis in callus is initiated with the formation of clusters of meristematic cells called meristemoids.

1966- Stroun, M. Anker, P., Charles, P. and Le Doux L made DNA transfer in tomato under *in vitro* conditions.

1970- Kasha, K. J and Kao, K.N produced haploid plants of *Hordeum vulgare* by *in vitro* culturing of embryos obtained by cross *Hordeum vulgare* with *Hordeum bulbosum* in which elimination of *bulbosum* chromosome occurred.

1971- Takebe, I., Labib, G. and Melchers, G regenerated whole plants from isolated mesophyll protoplasts of tobacco.

1971- Bendich, A.J. and Filner, P used the cells and tissues in culture for transformation studies.

1972- Withers, L. and Cocking, E.C laid foundation for the protoplast fusion technique.

1973- Potrykus, I made the first attempt on chloroplast and nucleus transfer from *Petunia hybrida* into albino protoplasts of the same species.

1974- Melchers, G. and Labib, G proposed hybrids resembling the sexual hybrids by fusing protoplasts of two varieties of *Nicotiana tabacum*

1974- Murashige, T developed the concept of developmental stages in cultures *in vitro*: Stage I: Explant establishment; Stage II: Multiplication of propagule and Stage III: Rooting and hardening for planting into soil.

1975- Morel, G established cold storage of regenerated plants for a year.

1976- Mullin, R.H. and Schlegel, D.E successfully employed cold storage to maintain *in vitro* virus free plantlets of strawberry.

1976- Seibert, M established shoot initiation from carnation shoot apices frozen to -196°C.

1978- Zelcer, A., Aviv, D. and Galun E developed a protoplast fusion procedure called Donor - Recipient protoplast fusion to favour organelle transfer among plants.

1979- Polacco, J.C. Sparks, R.B. and Havir, E.A described the cloning of soyabean urease structural gene by the vector mediated transfer system.

1980- Gleba Y. Y. and Hoffmann F synthesized a new plant "*Arabidobrassica* by fusing the protoplasts *Arabidopsis* and *Brassica*.

1981- Larkin, P.J. and Scowcroft, W.R developed the concept of somaclonal variation: A novel source of variability from cell cultures for plant improvement.

1981- Patnaik, G., Wilson, D. and Cocking, E.C regenerated a whole plant from a single free cultured tobacco protoplast.

1982- Krens, F.A., Molondijk, L. Williams G. J. and Schilperoort, R.A developed poly ethylene glycol method for the direct delivery of DNA into protoplasts.

1983- Zambryski, P. Joos, H., Genetello, C., Leemans, J. Van Montagu M. and Schell Constructed Ti plasmid vector for the introduction of DNA into plant cells without alteration of their normal regeneration capacity.

1984- Watts , J. W. and King, J. M developed a simple method for large scale electrofusion of protoplasts.

1984- Brisson, N. Paszkowski, J. Penswick, J. R. Gronenborn, B. Potrykus, I. and Hohn, T Achieved transformation in which part of the cauliflower mosaic virus genome was replaced by selectable marker.

1985- Gheysen, G. Dahese, P., Van Montaque, M. and Schell, J developed very efficient gene transfer system using natural gene transfer mechanism of *Agrobacterium tumifaciens*.

1985- Cocking E. C exposed plasma membrane in the tips of root hairs of wide range of crop plants. The procedure enabled whole seedlings to have the plasma membrane at the tips of their root hairs exposed to foreign DNA and other microorganisms.

1985- Tabata, M. and Fujita, Y developed the technique of elucidation of the physical and chemical factors controlling the biosynthesis of the red naphthoquinone pigments by *Lythospermum erythrorhizon*.

1986- Crossway, A. Oakes, J.V., Irvine , J.M., Ward B. Knauf, V.C. and Shewmaker, C.K developed a direct way of transferring cloned genes into protoplasts by microinjection of DNA directly into the nucleus of tobacco mesophyll protoplasts.

1986-Hamill, J. D. Parr, A. J., Robins, R. J. and Rhodes, M.J.C established hairy root cultures of *Beta vulgaris* and *Nicotinna rustica* following infection with *Agrobacterium rhizogenes* and the transformed cultures synthesized their characteristic secondary products at levels comparable with those of *in vitro* roots from the same variety.

1986- Abdullah, R., Cocking, E.C., and Thompson, J.A demonstrated that normal green rice plants can be regenerated efficiently and reproducibly from rice protoplasts *via* Somatic embryogenesis.

1986- Pirrie, A. and Power, J.B produced fertile, interspecific gametosomatic triploid hybrids of tobacco by fusing protoplasts of leaf (2n) and pollen tetrad (n).

1986- Kinsara A., Patnaik, S.N., Cocking, E.C. and Power, J.B produced somatic hybrids between *Lycopersicon esculentum* and *L. peruvianum*.

1987- Terada, R., Kyojuka, J., Nishibayashi, S., and Shimamoto, K regenerated plantlets form somatic hybrid cells of *Oryza sativa*, and *Echinochloa oryzicola*.

1987- Ethlenfelt, N.K. and Helgeson, J.P produced tetraploid and hexaploid somatic hybrids from protoplast fusions between *Solanum bravidens* (2x, non tuber bearing species) and 2x and 4x *S. tuberosum*.

1987- Neuhaus, G., Spangenberg, G. Mittelsten Sheid, O and Schweiger, H.G effected gene transfer by microinjecting the DNA into the cells of microspore derived proembryos.

1987- De la Pe\$á, A., Lornz, H., Schell, J developed transgenic rye plants obtained by injecting DNA into young floral tillers.

1988- Nomoru, K. and Komamine, A used single cells of carrot from a cell suspension instead of protoplasts, for microinjection and the microinjected carrot cells could divide and differentiated to embryos at a frequency of about 50 percent.

1988- Rhodes, C.A., Pierce, D.A., Mettler, I. J., Mascarenhas, D. and Detmer J.J produced transgenic maize plant by electroporation.

1988- Toriyama, K., Arimoto, Y. Uchimiya, H, and Hinata K produced transgenic rice plant by electroporation.

1989- Shimamoto, K., Terada, R., Izawa, T. and Fujimoto, H produced fertile transgenic rice plants regenerated from transformed protoplasts.

1989- Prioli, L. M. and Sondahl, M. R recovered fertile plants from protoplasts of maize.

1990- Milanova, V. and Zagorska, N. A succeeded in overcoming hybrid incompatibility between *Nicotiana africana* and *N. tabacum* and produced cytoplasmic male sterile plants by embryo culture.

1990- Iida, A., Seki, M. Kamada, M. YHamada Y. and Morikawa delivered genes into cultured plant cells by DNA-coated gold particles accelerated by a pneumatic particle gun.

1991- Kyozuka, J. Fujimoto, H., Izawa, T. and Shimamoto- K succeeded in getting tissue specific expression of maize alcohol dehydrogenase I gene in transgenic rice plants and their progenies.

1991- Spangenberg, G., Fredyl, E., Osusky, M. Nagel, J. and Potrykus, I developed a method for the predictable transfer of partial genomes predictable transfer of partial genomes by using sub protoplasts (cytoplasts and karyoplasts).

1991- Sautter, C., Waldner, H. Neuhaus, G., Galli, A. Neuhaus, G. and Potrykus developed a novel method for the acceleration of micro projectiles. The method is called as micro targeting.

The history of plant tissue culture had its real beginning in 1934 when Gautheret tried to cultivate isolated cells and root tips on organised medium. The momentum from this pioneering work, a new turn in this ongoing research occurred, because of World War II. After the Second World War, American plant pathologists became interested in plant tissue culture.

As **Steward (1970)** pointed out, the plant tissue culture technique is another "**Silent Revolution in Agriculture**" having very good potentials to supplement conventional breeding approaches. Its potentials and prospects are discussed in subsequent chapters. The techniques' theoretical aspects and their applicabilities are simplified and presented.

Genetic engineering

Manipulation of genes is called genetic engineering or recombinant DNA technology. It removes gene(s) from one organism and either

- Transfers them to another
- Puts them back in the original with a different combination

Current interest in genetic engineering centres on its various applications, such as:

- Isolation of a particular gene, part of a gene, or region of a genome
- Production of particular RNA and protein molecules in quantities formerly thought to be unobtainable
- Improvement in the production of biochemicals (such as enzymes and drugs) and commercially important organic chemicals
- Production of varieties of plants having particular desirable characteristics (for example, requiring less fertilizer or being resistant to disease)
- Correction of genetic defects in higher organisms
- Creation of organisms with economically important features (for example, plants capable of maturing faster or having greater yield).

The basic requirements for successful genetic engineering are

- Restriction enzymes
- Cloning vehicles (vectors) to carry the genes of interest
- Detection and selection of cloned genes.

Various gene transfer techniques used in genetic engineering includes

- **Agrobacterium mediated gene transfer:** Desired trait is isolated from DNA of original organism, inserted into *Agrobacterium*, target plant is infected. Cells that accept the DNA are grown into plants with the new trait.
- **Gene gun:** DNA that codes for the desired trait is coated onto tiny particles of tungsten and fired into a group of plant cells. Cells that accept the DNA are grown into plants with the desired trait.

A model genetic engineering of a plant comprises the following general steps:

- Selection of a plant gene whose introduction in other plants would be of positive agricultural value;
- Identification and isolation of such genes;
- Transference of isolated genes to the plant cell;
- Regeneration of complete plants from transferred cells or tissues.

Some of the goals of plant genetic engineers include production of plants that are

- Resistant to herbicide, insect, fungal and viral pathogens
- Improved protein quality and amino acid composition
- Improved photosynthetic efficiency,
- Improved post harvest handling.

This technology could provide an additional tool for the plant breeder who is trying to improve crops by traditional methods. In addition, plants can be viewed as a genetic resource, genes being cloned into, and expressed in bacteria. These bacteria may then be used to produce desirable plant products on an industrial scale using fermenter. The first transgenic plants expressing engineered foreign genes were recovered in 1984.

Dramatic progress has been made in the last few years in the development of a gene transfer system for higher plants. About 20 crops can be genetically engineered at present. Rapid progress is being made in the genetic manipulation of many species and almost every month another successful plant transformation is reported.

Questions

1. Callus formation in the decorticated elm tree was discovered by

- a) **Duharmel du Monceau**
- b) Morgan, T.H
- c) Haberlandt
- d) Rechinger

2. Who's work was foreword for the discovery of plant tissue culture?.

- a) **Duharmel du Monceau**
- b) Morgan, T.H
- c) Haberlandt
- d) Rechinger

3. Name the scientist who expressed the view that each living cell of a multicellular organism would be capable of developing independently if provided with proper external conditions.

- a) Duharmel du Monceau
- b) **Schwann**
- c) Haberlandt
- d) Rechinger

4. Name the scientist who proposed the polarity in development of buds from the upper portion and roots or callus and from the lower portion of a stem piece.

- a) Duharmel du Monceau
- b) Morgan, T.H
- c) Haberlandt
- d) **Vochting**

5. Callus formation on isolated stem fragments and root slices is described by

- a) Duharmel du Monceau
- b) Morgan, T.H
- c) Haberlandt
- d) **Rechinger**

6. The term totipotency was coined by

- a) Duharmel du Monceau
- b) **Morgan, T.H**
- c) Haberlandt
- d) Rechinger

7. The term totipotency means

- a) **the capability of a cell to form an individual plant**
- b) the capability of a cell to form an individual cell
- c) both a & b
- d) None of the above

16. Kinetin was identified by

- a) Miller
- b) Skoog
- c) Von Saltza and Strong
- d) All the above**

17. The phenomenon of somatic embryogenesis in suspension culture of carrot was observed by

- a) Steward
- b) Mapes
- c) Mears
- d) All the above**

18. The first suspension culture by transferring callus fragments to agitated liquid medium was obtained by

- a) Hildebrandt
- b) Riker
- c) Muir
- d) All the above**

19. The somatic embryo formation from callus cultures of carrot grown on an agarified medium was observed by

- a) Hildebrandt
- b) Reinert**
- c) Muir
- d) All the above

20. the technique of isolation and culture of protoplasts after digesting the cell walls enzymatically was discovered by

- a) Hildebrandt
- b) Cocking**
- c) Muir
- d) All the above

21. The plating technique was invented by

- a) Bergmann**
- b) Riker
- c) Muir
- d) All the above

22. Meristem culture was discovered by

- a) Bergmann
- b) Riker
- c) Morel**
- d) All the above

23. Anther culture was discovered by

Scope and importance in crop improvement

Tissue-culture techniques are part of a large group of strategies and technologies, ranging through molecular genetics, recombinant DNA studies, genome characterization, gene-transfer techniques, aseptic growth of cells, tissues, organs and in vitro regeneration of plants that are considered to be plant biotechnologies. The use of the term biotechnology has become widespread recently but, in its most restricted sense, it refers to the molecular techniques used to modify the genetic composition of a host plant, i.e. genetic engineering. The applications of various tissue-culture approaches to crop improvement, through breeding, wide hybridization, haploidy, somaclonal variation and micro propagation are discussed in this chapter.

Plant breeding and biotechnology

Plant breeding can be conveniently separated into two activities: manipulating genetic variability and plant evaluation. Historically, selection of plants was made by simply harvesting the seeds from those plants that performed best in the field. Controlled pollination of plants led to the realization that specific crosses could result in a new generation that performed better in the field than either of the parents or the progeny of subsequent generations, i.e. the expression of heterosis through hybrid vigour was observed. Because one of the two major activities in plant breeding is manipulating genetic variability, a key prerequisite to successful plant breeding is the availability of genetic diversity. It is in this area, creating genetic diversity and manipulating genetic variability, that biotechnology including tissue-culture techniques is having its most significant impact. In spite of the general lack of integration of most plant-biotechnology and plant-breeding programmes, field trials of transgenic plants have recently become much more common. More than 50 different plant species have already been genetically modified, either by vector-dependent (e.g. *Agrobacterium*) or vector-independent (e.g. biolistic, micro-injection and liposome) methods. In almost all cases, some type of tissue-culture technology has been used to recover the modified cells or tissues. In fact, tissue-culture techniques have played a major role in the development of plant genetic engineering. Tissue culture will continue to play a key role in the genetic-engineering process for the foreseeable future, especially in efficient gene transfer and transgenic plant recovery.

Wide hybridization

A critical requirement for crop improvement is the introduction of new genetic material into the cultivated lines of interest, whether via single genes, through genetic engineering, or multiple

genes, through conventional hybridization or tissue-culture techniques. During fertilization in angiosperms, pollen grains must reach the stigma of the host plant, germinate and produce a pollen tube. The pollen tube must penetrate the stigma and style and reach the ovule. The discharge of sperm within the female gametophyte triggers syngamy and the two sperm nuclei must then fuse with their respective partners. The egg nucleus and fusion nucleus then form a developing embryo and the nutritional endosperm, respectively. This process can be blocked at any number of stages, resulting in a functional barrier to hybridization and the blockage of gene transfer between the two plants.

Pre-zygotic barriers to hybridization (those occurring prior to fertilization), such as the failure of pollen to germinate or poor pollen-tube growth, may be overcome using *in vitro* fertilization. Post-zygotic barriers (occurring after fertilization), such as lack of endosperm development, may be overcome by embryo, ovule or pod culture. Where fertilization cannot be induced by *in vitro* treatments, protoplast fusion has been successful in producing the desired hybrids. *In vitro fertilization* IVF has been used to facilitate both interspecific and intergeneric crosses, to overcome physiological-based self incompatibility and to produce hybrids. A wide range of plant species has been recovered through IVF via pollination of pistils and self and cross-pollination of ovules. This range includes agricultural crops, such as tobacco, clover, corn, rice, cole, canola, poppy and cotton. The use of delayed pollination, distant hybridization, pollination with abortive or irradiated pollen, and physical and chemical treatment of the host ovary have been used to induce haploidy.

Embryo culture

The most common reason for post-zygotic failure of wide hybridization is embryo abortion due to poor endosperm development. Embryo culture has been successful in overcoming this major barrier as well as solving the problems of low seed set, seed dormancy, slow seed germination, inducing embryo growth in the absence of a symbiotic partner, and the production of monoploids of barley. The breeding cycle of *Iris* was shortened from 2 to 3 years to a few months by employing embryo rescue technology. A similar approach has worked with orchids and roses and is being applied to banana and *Colocasia*. Interspecific and intergeneric hybrids of a number of agriculturally important crops have been successfully produced, including cotton, barley, tomato, rice, jute, *Hordeum X Secale*, *Triticum x Secale*, *Tripsacum x lea* and some Brassicas. At least seven Canadian barley cultivars (Mingo, Rodeo, Craig, Winthrop, Lester and TB891-6) have been produced out of material selected from doubled haploids originating

through the widely-used *bulbosum* method of cross-pollination and embryo rescue. Briefly, *Hordeum vulgare* ($2n = 14$) is pollinated with pollen from *H. bulbosum* ($2n = 14$). Normally, the seeds develop for about 10 days and then abort but, if the immature embryos are rescued and cultured on basal growth medium, plants can be recovered. The plants resulting from this cross-pollination/embryo rescue are haploids rather than hybrids and are the result of the systematic elimination of the *H. bulbosum* chromosomes. Haploid wheat has also been produced by this technique.

Protoplast fusion

Protoplast fusion has often been suggested as a means of developing unique hybrid plants which cannot be produced by conventional sexual hybridization. Protoplasts can be produced from many plants, including most crop species. However, while any two plant protoplasts can be fused by chemical or physical means, production of unique somatic hybrid plants is limited by the ability to regenerate the fused product and sterility in the interspecific hybrids rather than the production of protoplasts. Perhaps the best example of the use of protoplasts to improve crop production is that of *Nicotiana*, where the somatic hybrid products of a chemical fusion of protoplasts have been used to modify the alkaloid and disease-resistant traits of commercial tobacco cultivars.

Somatic hybrids were produced by fusing protoplasts, using a calcium-polyethylene glycol treatment, from a cell suspension of chlorophyll-deficient *N. rustica* with an albino mutant of *N. tabacum*. The wild *N. rustica* parent possessed the desirable traits of high alkaloid levels and resistance to black root rot. Fusion products were selected as bright green cell colonies, the colour being due to the genetic complementation for chlorophyll synthesis the hybrid cells. Plants recovered by shoot organogenesis showed a wide range of leaf alkaloid content but had a high level of sterility. However, after three backcross generations to the cultivated *N. tabacum* parent, plant fertility was restored in the hybrid lines, although their alkaloid content and resistance to blue mould and black root rot were highly variable. Interestingly, neither parent was known to possess significant resistance to blue mould.

Two commercial varieties, Delgold and AC Chang, have been released from the progeny of these protoplast fusion products and are presently grown on approximately 42% of the fluecured tobacco acreage in Ontario, Canada. This represents a value of approx. US\$199,000,000. Where mutant cell lines of donor plants are not available for use in a genetic complementation

selection system, it has been demonstrated that mesophyll protoplasts from donor parents carrying transgenic antibiotic resistance can be used to produce fertile somatic hybrids selected by dual antibiotic resistance. The fusion of protoplasts from 6-azauracil-resistant cell lines of *Solanum melongena* (aubergine) with protoplasts from the wild species *S. sisymbriifolium* yielded hybrid, purple-pigmented cell colonies that underwent regeneration via organogenesis. As protoplasts from the parental cell suspension cultures could not be regenerated, hybrids could be screened by their 6-azauracil resistance, capacity to synthesize anthocyanins (purple pigment) and ability to undergo shoot organogenesis. The restoration of regeneration ability through complementation has also been observed in *Nicotiana* cell-fusion products. The hybrids resulting from this study were found to be resistant to root knot nematodes and spider mites, important agricultural traits. However, they were also completely sterile and could not be incorporated into an aubergine-breeding programme. Two possible ways of solving this sterility problem, 'back' fusions of somatic hybrids with the cultivated parents and initiation of suspension cultures of the hybrid cells so that more of the wild species chromosomes can be eliminated, have so far been unsuccessful with these hybrids. Selection of hybrids and use of protoplast fusion for hybridization in crop plants has been reported in Brassicas, citrus, rice, carrot, canola, tomato, and the forage legumes alfalfa and clover. Evans & Bravo (1988) have recommended that production of novel hybrids through protoplast fusion should focus on four areas: (1) agriculturally important traits; (2) achieving combinations that can only be accomplished by protoplast fusion; (3) somatic hybrids integrated into a conventional breeding programme; and (4) the extension of protoplast regeneration to a wider range of crop species.

Haploids

Haploid plants are of interest to plant breeders because they allow the expression of simple recessive genetic traits or mutated recessive genes and because doubled haploids can be used immediately as homozygous breeding lines. The efficiency in producing homozygous breeding lines via doubled *in vitro*-produced haploids represents significant savings in both time and cost compared with other methods. Three *in vitro* methods have been used to generate haploids

- (1) Culture of excised ovaries and ovules;
- (2) The *bulbosum* technique of embryo culture; and
- (3) Culture of excised anthers and pollen.

A present, 171 plant species have been used to produce haploid plants by pollen, microspore and anther culture. These include cereals (barley, maize, rice, rye, triticale and wheat), forage crops (alfalfa and clover), fruits (grape and strawberry), medicinal plants (*Digitalis* and

Hyoscyamus), ornamentals (*Gerbera* and sunflower), oil seeds (canola and rape), trees (apple, litchi, poplar and rubber), plantation crops (cotton, sugar cane and tobacco), and vegetable crops (asparagus, brussels sprouts, cabbage, carrot, pepper, potato, sugar beet, sweet potato, tomato and wing bean). Haploid wheat cultivars, derived from anther culture, have been released in France and China. Five to 7 years were saved producing inbred lines in a Chinese maize-breeding programme by using anther culture-derived haploids. A similar saving has been reported for triticale and the horticultural crop *Freesia*. In asparagus, anther-derived haploids have been used to produce an all-male F₁ hybrid variety in France.

Somaclonal variation

In addition to the variants/mutants (cell lines and plants) obtained as a result of the application of a selective agent in the presence or absence of a mutagen, many variants have been obtained through the tissue-culture cycle itself. These soma clonal variants, which are dependent on the natural variation in a population of cells, may be genetic or epigenetic, and are usually observed in the regenerated plantlets. Somaclonal variation itself does not appear to be a simple phenomenon, and may reflect pre-existing cellular genetic differences or tissue culture- induced variability. The variation may be generated through several types of nuclear chromosomal re-arrangements and losses, gene amplification or de-amplification: non-reciprocal mitotic recombination events, transposable element activation, apparent point mutations, or re-activation of silent genes in multigene families, as well as alterations in maternally inherited characteristics. Many of the changes observed in plants regenerated *in vitro* have potential agricultural and horticultural significance. These include alterations in plant pigmentation, seed yield, plant vigour and size, leaf and flower morphology, essential oils, fruit solids and disease tolerance or resistance. Such variations have been observed in many crops, including wheat, triticale, rice, oats, maize, sugar cane, alfalfa, tobacco, tomato, potato, oilseed rape and celery. The same types of variation obtained from somatic cells and protoplasts can also be obtained from gametic tissue. One of the major potential benefits of somaclonal variation is the creation of additional genetic variability in co adapted, agronomically useful cultivars, without the need to resort to hybridization. This method could be valuable if selection is possible *in vitro*, or if rapid plant-screening methods are available. It is believed that somaclonal variants can be enhanced for some characters during culture *in vitro*, including resistance to disease pathotoxins and herbicides and tolerance to environmental or chemical stress. However, at present few cultivars of any agronomically important crop have been produced through the exploitation of somaclonal variation.

Micropropagation

During the last 30 years it has become possible to regenerate plantlets from explants and/or callus from all types of plants. As a result, laboratory-scale micropropagation protocols are available for a wide range of species and at present micropropagation is the widest use of plant tissue-culture technology. The cost of the labour needed to transfer tissue repeatedly between vessels and the need for asepsis can account for up to 70% of the production costs of micropropagation. Problems of vitrification, acclimatization and contamination can cause great losses in a tissue-culture laboratory. Genetic variations in cultured lines, such as polyploidy, aneuploidy and mutations, have been reported in several systems and resulted in the loss of desirable economic traits in the tissue-cultured products. There are three methods used for micropropagation:

- (1) Enhancing axillary-bud breaking;
- (2) Production of adventitious buds; and
- 3) Somatic embryogenesis. In the latter two methods, organized structures arise directly on the explant or indirectly from callus.

Axillary-bud breaking produces the least number of plantlets, as the number of shoots produced is controlled by the number of axillary buds cultured, but remains the most widely used method in commercial micropropagation and produces the most true to- type plantlets. Adventitious budding has a greater potential for producing plantlets, as bud primordia may be formed on any part of the inoculum. Unfortunately, somatic embryogenesis, which has the potential of producing the largest number of plantlets, can only presently be induced in a few species.

Synthetic seed

A synthetic or artificial seed has been defined as a somatic embryo encapsulated inside a coating and is considered to be analogous to a zygotic seed. There are several different types of synthetic seed: somatic embryos encapsulated in a water gel; dried and coated somatic embryos; dried and uncoated somatic embryos; somatic embryos suspended in a fluid carrier; and shoot buds encapsulated in a water gel. The use of synthetic seeds as an improvement on more traditional micropropagation protocols in vegetatively propagated crops may, in the long term, have tissue *culture* and *crop improvement* a cost saving, as the labour intensive step of transferring plants from in vitro to soil/field conditions may be overcome. Other applications include the maintenance of male sterile lines, the maintenance of parental lines for hybrid crop production, and the preservation and multiplication of elite genotypes of woody plants that have long juvenile developmental phases. However, before the widespread application of this

technology, somaclonal variation will have to be minimized, large-scale production of high quality embryos must be perfected in the species of interest, and the protocols will have to be made cost-effective compared with existing seed or micropropagation technologies.

Pathogen eradication

Crop plants, especially vegetatively propagated varieties, are generally infected with pathogens. Strawberry plants are susceptible to over 60 viruses and mycoplasmas and this often necessitates the yearly replacement of mother plants. In many cases, although the presence of viruses or other pathogens may not be obvious, yield or quality may be substantially reduced as a result of the infection. In China, for example, virus-free potatoes, produced by culture in vitro, gave higher yields than the normal field plants, with increases up to 150%. As only about 10% of viruses are transmitted through seeds, careful propagation from seed can eliminate most viruses from plant material. Fortunately, the distribution of viruses in a plant is not uniform and the apical meristems either have a very low incidence of virus or are virus-free. The excision and culture of apical meristems, coupled with thermo- or chemo-therapy, have been successfully employed to produce virus-free and generally pathogen-free material for micropropagation.

Germplasm preservation

One way of conserving germplasm, an alternative to seed banks and especially to field collections of clonally propagated crops, is in vitro storage under slow-growth conditions (at low temperature and/or with growth-retarding compounds in the medium) or cryopreservation or as desiccated synthetic seed. The technologies are all directed towards reducing or stopping growth and metabolic activity. Techniques have been developed for a wide range of plants. The most serious limitations are a lack of a common method suitable for all species and genotypes, the high costs and the possibility of somaclonal variation and non-intentional cell-type selection in the stored material (e.g. aneuploidy due to cell division at low temperatures or non-optimal conditions giving one cell type a selective growth advantage).

Plant tissue-culture technology is playing an increasingly important role in basic and applied studies, including crop improvement. In modern agriculture, only about 150 plant species are extensively cultivated. Many of these are reaching the limits of their improvement by traditional methods. The application of tissue-culture technology, as a central tool or as an adjunct to other

methods, including recombinant DNA techniques, is at the vanguard in plant modification and improvement for agriculture, horticulture and forestry.

Questions

1. Pre-zygotic barriers to hybridization are

- a) Failure of pollen to germinate
- b) Poor pollen-tube growth
- c) Both a & b**
- d) None of the above

2. Post-zygotic barriers to hybridization are

- a) Failure of pollen to germinate
- b) Poor pollen-tube growth
- c) Lack of endosperm development**
- d) None of the above

3. Pre-zygotic barriers to hybridization can be overcome by

- a) *In vitro* fertilization**
- b) Embryo culture
- c) Ovule culture
- d) Pod culture

4. Post-zygotic barriers to hybridization can be overcome by

- a) Pod culture
- b) Embryo culture
- c) Ovule culture
- d) All the above**

5. Embryo culture has been successful in overcoming the problems.....

- a) Low seed set
- b) Seed dormancy
- c) Slow seed germination
- d) All the above**

6. Delgold and AC Chang are the commercial varieties of produced by protoplast fusion

- a) Tobacco**
- b) Potato
- c) Tomato
- d) None of the above

7. The production of novel hybrids through protoplast fusion should focus on

- a) Agriculturally important traits
- b) Somatic hybrids integrated into a conventional breeding programme

c) Extension of protoplast regeneration to a wider range of crop species **d) All the above**

8. *In vitro* methods used to generate haploids

- a) Culture of excised ovaries and ovules b) *Bulbosum* technique of embryo culture
c) Culture of excised anthers and pollen **d) All the above**

9. The methods used for *in vitro* propagation

- a) Enhancing axillary-bud breaking b) Production of adventitious buds
c) Somatic embryogenesis **d) All the above**

Totipotency and Morphogenesis

Totipotency

The inherent potentiality of a plant cell to give rise to a whole plant is described as cellular totipotency. This is a capacity which is retained even after a cell has undergone final differentiation in the plant body. In plants, even highly mature and differentiated cells retain the ability to regenerate to a meristematic state as long as they have an intact membrane system and a viable nucleus. This is contradicting to animals, where differentiation is generally irreversible.

For a differentiated cell, to express its totipotency, it first undergoes dedifferentiation followed by redifferentiation. The phenomenon of a mature cell reverting to the meristematic state and forming undifferentiated callus tissue is termed 'dedifferentiation'. The phenomenon of conversion of component cells of callus tissue to whole plant or plant organs is called as 'redifferentiation'.

The phenomenon of totipotency is demonstrated with the following experiment. Slices of the carrot root (shown on the left) were cut and small pieces of tissues were taken from the phloem region. These were inoculated into a liquid medium in special flasks, which were rotated slowly. The tissue grew actively and single cells and small cell aggregates dissociated into the medium (a single cell and some cell aggregates are drawn near the flask). Some of the cell clumps developed roots, and, when transferred to a semi-solid medium, these rooted nodules formed shoots. These plants could be transferred to soil where they developed into flowering plants. Phloem tissues taken from the roots of these plants could be used to repeat the cycle.

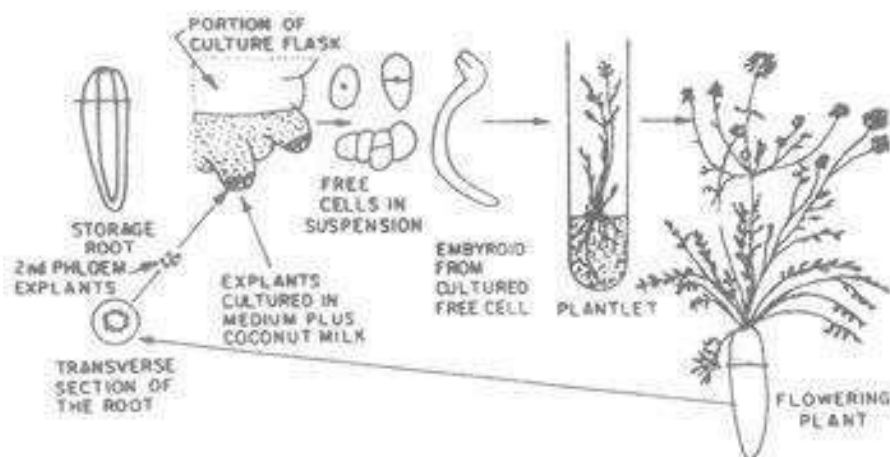

Morphogenesis

Biological organization of any life coordinated with several events as though a craftsman was moulding it according to a plan. In this process, the individual parts do not develop independently but all are knit together into an organised system. The biological science concerned with this dynamic and casual aspect of organic form is called "Morphogenesis". The derivation of this word is obvious, the origin of form. It attempts to expose the effects of various factors and how these factors manifest an organic form *in toto*. "Morphogenesis", a distinctive aspect of organization of life, is the crossroad where all the highways of biological exploration tend to converge", says Sinnott.

More studies have been made to understand morphogenetic problems of animals rather than plants. Recent developments in plant cells, tissues and organs of higher plants in culture, are making the science of plant morphogenesis a fruitful one. Working with plants has a number of advantages.

- In plants embryonic regions like meristem and cambium are permanently available for the study of development.
- The determinate type of development and abundance of organs such as leaves; flowers and fruits make the study possible under a wide range of environmental conditions.
- The behaviour of individual cells during development differs in plants from animals. In animals, the individual cells are free to move whereas this mobility is absent in plants and the cells are almost always attached firmly to the neighbours so that morphogenetic movements have no part in the development. This makes the study of morphogenetic problems simple in plants.
- The lesser plasticity of plant cells, their stationary habit, susceptibility to changes under environmental influences, ability to maintain polarity and differentiation and generation potential favour the study relatively simple one.

In the field of plant morphogenesis, the contributions were made by the scientists like, Hanstein on meristem, Winkler on chimeras, Haberlandt on hormones, Kuster on abnormal growth, Klebs on the effects of the environment and Goebel on the organography are noteworthy. Vochting (1878) stated in his "Organbildung im Pflanzenseich" that phenomenon of morphogenesis depends on the factors like polarity, differentiation and regeneration of individual cells and concluded that the fate of a cell is a function of its position.

Morphogenesis *in vitro*

Under normal conditions, a seed, the miniaturized sporophyte has the message to reconstitute an entire plant with similar shape, structure and function of the mother plant. All known about this phenomenon is that a complex adult multicellular organism has emerged from a relatively simple organized zygote through a sequence of mitosis. This *de novo* origin of structures and functions from a fertilized egg or zygote is a complicated phenomenon in which most of the events are not yet known in detail. This is the state in plants *in vivo* or in an entire plant. Considering the cells or organs cultured *in vitro*, the morphogenesis is still an event without many details. However, in the aspects of morphogenesis *in vitro*, significant progress has been made, after the discovery of totipotency of plant cells, phytohormones and the hypothesis of regulation of morphogenesis by the critical balance between auxin and cytokinin.

Various terms are used to define the phenomenon in *in vitro* studies. For example differentiation, de-differentiation, re-differentiation, regeneration and morphogenesis are terms with overlapping meanings. To give a clear-cut view for the usage of terms, the sharp differences among them exposed hereunder.

Differentiation

The term differentiation is used in many different senses in biology. In broad sense, it is defined as the process by which meristematic cells are converted into two or more types of cells, tissues or organs which are qualitatively different from each other.

De-differentiation

The term is used to denote the process of formation of unorganised tissues from the highly organized tissues.

Re-differentiation

The process of differentiation occurring in an undifferentiated tissue.

Regeneration

It is defined as the structuring of any part, which has been removed or physiologically isolated from the organism. In other words, genesis of an entire plant from cultured explants directly or *via callus* indirectly is called regeneration.

Morphogenesis

Attainment of biological organization or form is termed as morphogenesis. Under *in vitro* conditions this can be achieved by two routes: *de novo* origin of organs, either shoots or roots from the cultured tissues precisely termed as organogenesis and *de novo* origin of embryos with distinct root and shoot poles on opposite ends from the somatic cells or cells cultured *in vitro*, otherwise called as somatic embryogenesis

Figure 1. Stages of callus induction

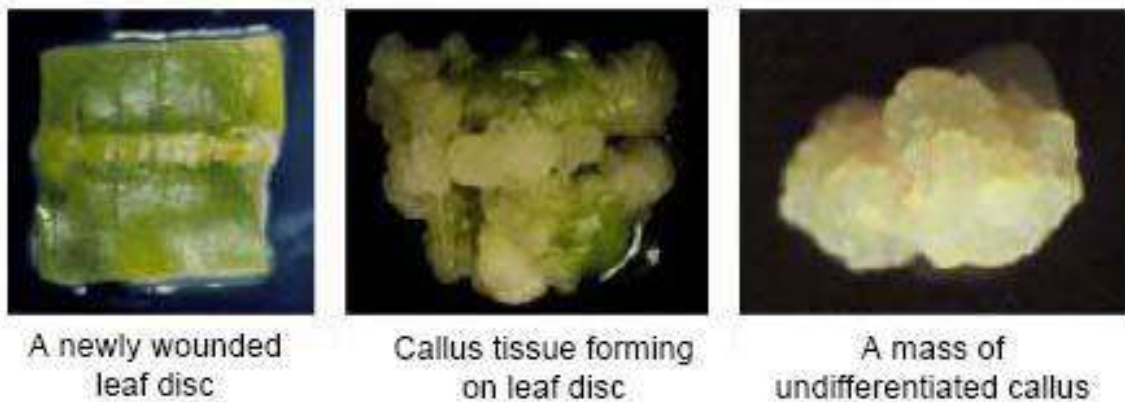

The historical background, achievements and the causes for the two routes are discussed below.

Organogenesis

In plant tissue culture, organogenesis means genesis of organs like shoots, roots, leaves, flowers, etc. The earliest report on induction of shoot organogenesis *in vitro* was by White (1939) using a tobacco hybrid; and the first observation of root formation was reported by Nobecourt (1939) using carrot callus. Till late 1950s, the basic regulatory mechanism underlying in organogenesis was not identified. Skoog and Miller (1957) were responsible to recognize the regulatory mechanism as a balance between auxin and cytokinin. As per their finding, a relatively high level of auxin to cytokinin favoured root formation and the reverse favoured shoot formation. Using this concept, it has now become possible to achieve organogenesis in a large number of plant species by culturing explants, calli and cell suspension in a defined medium.

In organogenesis, the shoot or root may form first depending upon the nature of growth hormones in the basal medium. The genesis of shoot and root from the explants or calli is

termed as caulogenesis (caulm = stem) and rhizogenesis (rhizo = root) respectively.

Figure 2. Pathways of *in vitro* organogenesis

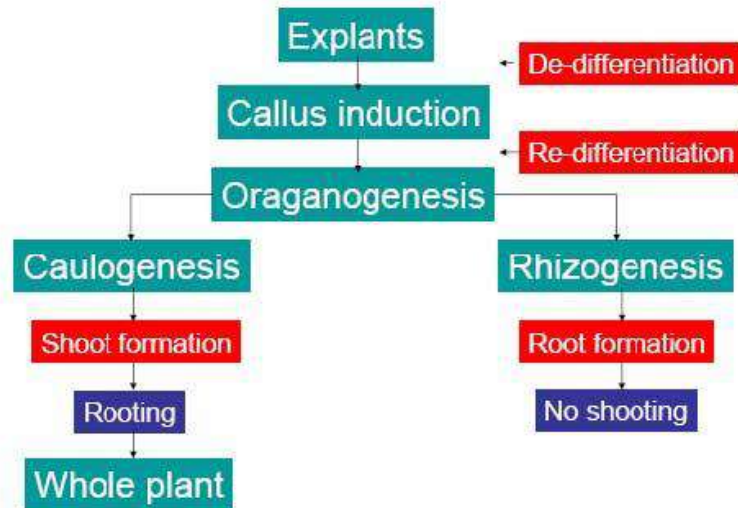

Events during organogenesis

It is a general rule that the organ formation would be through a process of differentiation in the undifferentiated mass of parenchyma. Most of the parenchymatous cells are highly vacuolated and with inconspicuous nuclei and cytoplasm, sometimes with lignification. In this group of cells, regions showing random cell division would occur, leading to radial files of differentiated tissues. These scattered cell division regions would form regions of high mitotic activity resulting in the formation of meristematic centres, otherwise termed as meristemoids. These meristemoids may be either on the surface of the calli or embedded in the tissue. Continued cell division in these meristemoids would produce small protuberances on the surface of the calli, giving nodular appearance to the tissues. From the meristemoids, the primordia of organs by repeated mitotic activity form either shoot or root. This was discovered by Torrey in 1966.

The meristemoids consist of a spherical mass of small isodiametric meristematic cells with dense cytoplasm and a high nucleo-cytoplasmic ratio. Normally, callus tissues accumulate starch and other crystals before organogenesis, but the substances disappear during meristemoid formation. During the initial stages of meristemoid formation, the cytoplasmic protrusions enter the vacuoles thus distributing the vacuoles around the periphery of each cell or dispersed throughout the cytoplasm. The nucleus is in the centre with maximum possible size. Thus cells in the meristemoids resemble the cells of highly active meristem in

an intact plant.

Figure 3. Stages of organogenesis

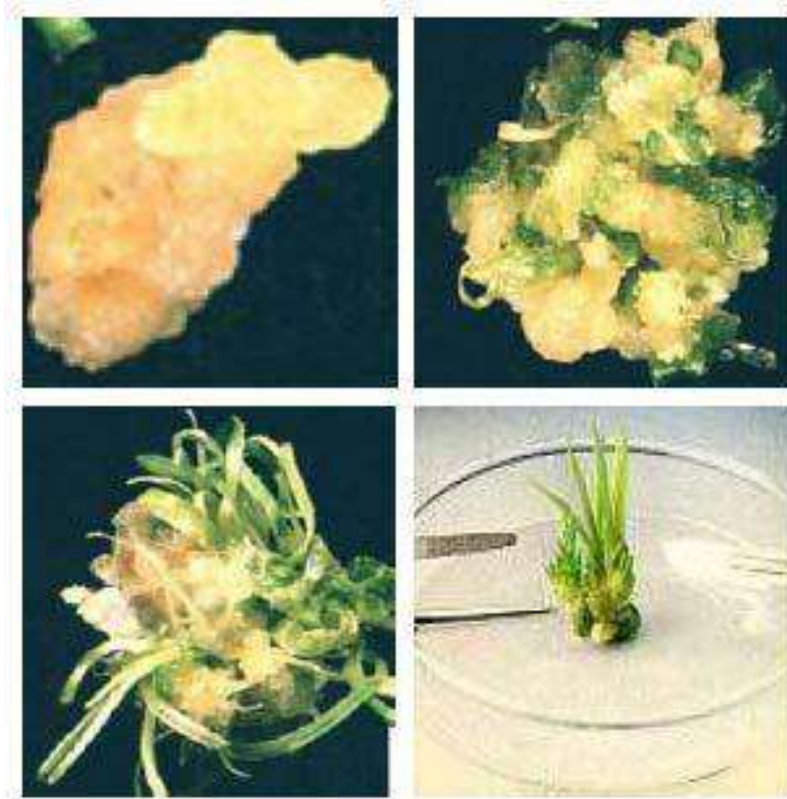

Embryogenesis

An embryo is defined as a plant in its initial stage of development. Each embryo possesses two distinct poles, one to form root and the other shoot, and is the product of fusion of gametes. In some plant species, embryos are produced without the fusion of gametes and termed as asexual embryogenesis or adventitious embryony.

In an intact plant this type of embryogenesis may occur in sporophytic tissues like integuments and nucellar tissues or from unfertilized gametic cells. Apart from the normal course of embryo formations *viz.*, zygotic embryogenesis and adventitious embryony, instances of embryo formations from the tissues cultures *in vitro* were reported. This phenomenon termed as somatic embryogenesis was first observed by Steward and his co-workers (1958) in suspension cultures of carrot followed by Reinert (1959). Since then, a number of reports of embryo formation have been published.

Figure 4. A comparison of somatic and zygotic embryogenesis

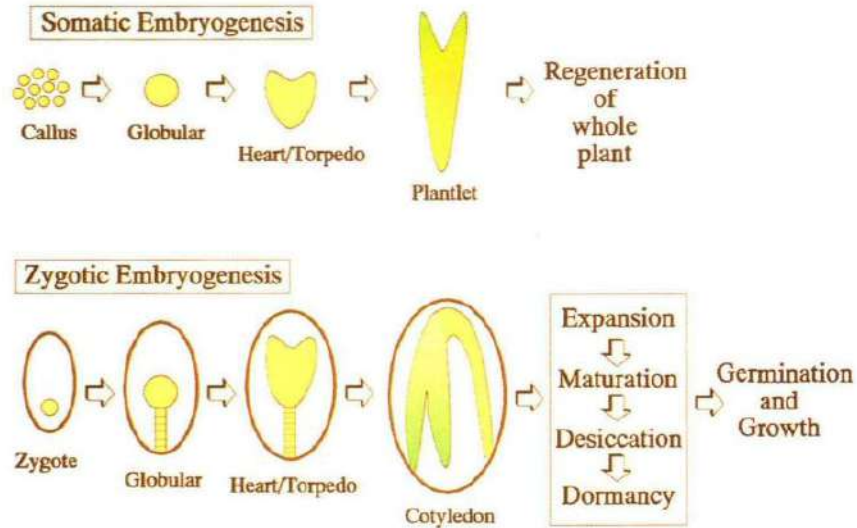

Morphologically and developmentally, somatic and zygotic embryos are most similar from the globular stage through the torpedo stage. Somatic embryos do not experience desiccation or dormancy, but rather continue to grow into fully differentiated plantlets.

Somatic embryogenesis or embryogenesis *in vitro* produces embryo like structures resembling the zygotic embryos in structure and morphogenetic potential. Despite this resemblance, the ontogeny of an embryo like structure from somatic cell differs from that of zygotic embryo, where the origin is from a single cell.

Figure 5. Pathway of somatic embryogenesis

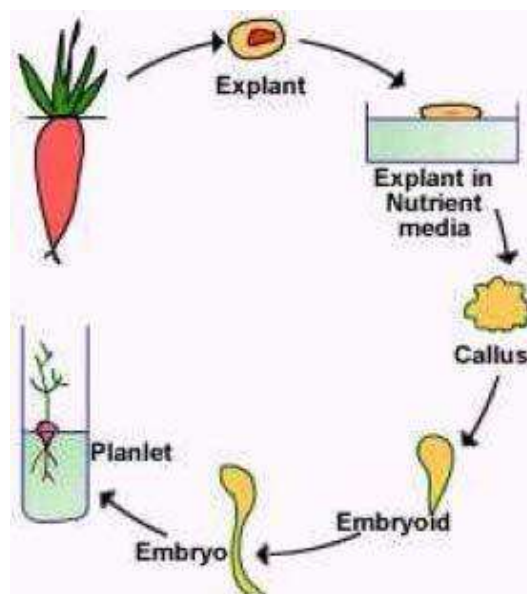

Embryoid is generally used to denote the embryo like structure from cultured tissues. These embryoids possess bipolarity, no vascular connection with the mother tissue and origin from a single cell or a group of cells.

Theories on embryogenesis

Several theories have been proposed to explain the phenomenon of somatic embryogenesis, of which the following are considered important.

Cell isolation theory: Steward and his co-workers proposed this theory in 1964. According to them, the embryo producing cells are isolated from the neighbouring cells in a cell mass. The isolation of cells, favours the embryogenesis. The isolation of cell may be induced by the constraints in the surrounding cells, due to physical and physiological separation of cells. In most cases, the connection of plasmodesmata was severed. But this generally appears to be secondary to the induction process.

Differentiation theory: This theory states that the embryos would not be produced from the differentiated cells of the explants. The cells of explants have to undergo de-differentiation to form callus. Then the cells of callus will produce embryos. In other words, de-differentiation in cells is a prerequisite for the production of somatic embryos *in vitro*.

That the embryos can be formed directly from the epidermal cells of the stem or hypocotyl indicate the possibility of embryo formation without de-differentiation. The need for differentiation depends on the explant material used during primary culture. Epidermal cells of the stem, hypocotyl and young embryos may begin embryo development without going through a callus stage, while cortical cells and cells of xylem and phloem explants require de-differentiation. This theory was proposed by Halperin in 1970.

Intercellular communication and cytodifferentiation theory: According to this theory, cytodifferentiation in cells due to intercellular communication induces embryo formation. The cytodifferentiation is regulated by diffusion gradients of nutrients, endogenous plant growth regulators and gaseous factors like O₂, CO₂ and ethylene. The changing microclimate in the culture environment affects intercellular communication and in turn cytodifferentiation. This concept was proposed by Street (1973).

Explant physiology and culture environment theory: This concept was developed by Street in 1976. He is of the view that the embryogenesis is a dependent phenomenon on the

explant and the culture environment. Explants like flower buds, young embryos and parts of young seedling are most responsive to produce somatic embryos, but not from those of mature plants. Apart from the explant physiology, culture environment is also a factor influencing the embryogenesis. For example, highly embryogenic callus culture can be maintained non-embryogenic if the medium is supplemented with high level of auxin and the same may be induced to produce embryos when transferred to auxin free medium.

Pre-determination theory: This was proposed by Tisserat *et al.* (1979). It states that the embryo production potential is pre-determined phenomenon in the cells and the *in vitro* culture provides the opportunity for embryogenesis. In other words, embryogenesis from a cell is an inherent one which is facilitated to produce embryos by optimal culture environment.

Pre and induced embryogenic determined cell theory: Though the embryogenesis is pre-determined one there are instances of non-formation of embryos directly from the explants. In these cases, an intervening callus stage comes between the primary explant and the embryos. The cells in the calli are induced to produce embryos by the manipulation of medium with relevant growth regulator. Based on this, the above theory was proposed by Sharp and his co-workers. According to this theory, there are two types of embryogenic cells: pre-embryogenic determined cells (PEDC) and induced embryogenic determined cells (IEDC).

In pre-embryogenic determined embryogenic cells, embryogeny is determined prior to mitosis while induced embryogenic determined cells the embryogeny is induced by providing suitable mitogenic substance i.e., the embryogeny is induced in the cells of callus by the application of plant growth regulators. Thus in the callus, embryogenic precursor cells or embryogenic mother cells are formed which then develop into embryogenic cells. Later these cells undergo polarised cell divisions typical of normal embryogenesis by forming globular, heart and torpedo shaped embryos.

Events during embryogenesis

In 1959, Reinert made the remarkable claim that following a succession of changes of the nutrient media, root derived callus tissue of *Daucus carota* produced normal bipolar embryos. The changes made or observed in the nutrient medium were as follows: maintenance of callus in White's medium with high level of auxin (IAA at 10 mg/litre) and subculturing of callus for several months on White's basal medium with additives like

vitamins, amino acids, amides and purines. As a result of these manipulations, the calli showed small protuberances on the surface. Histological sections of these calli showed centres of organised development. These tissues with organised centres, on transfer to auxin lacking but coconut milk containing medium produced embryoids and from embryoids, whole plants.

Figure 6. Stages of somatic embryogenesis



Patterns of embryogenesis

Two general patterns of embryogenesis *in vitro* are identified. Origin of embryos directly from the tissue cultured *in vitro* (direct embryogenesis) and origin of embryos *via* callus stage (indirect embryogenesis).

Differences between direct and indirect embryogenesis

Direct embryogenesis	Indirect embryogenesis
Embryos form from the explants directly	Embryos arise from the callus induced from the explants
A promoting substance to induce the embryo formation is needed	Auxin is need to induce callus, and cytokinin is needed to induce differentiation
The embryogenic nature of a cell is predetermined	The embryogenic nature of a cell is induced in the culture
The origin of embryos mostly from individual cells; sometimes from a group of cells	The origin may be either from single cells or from a group of cells called pro-embryonal complex

Figure 7. Direct somatic embryogenesis in sorghum

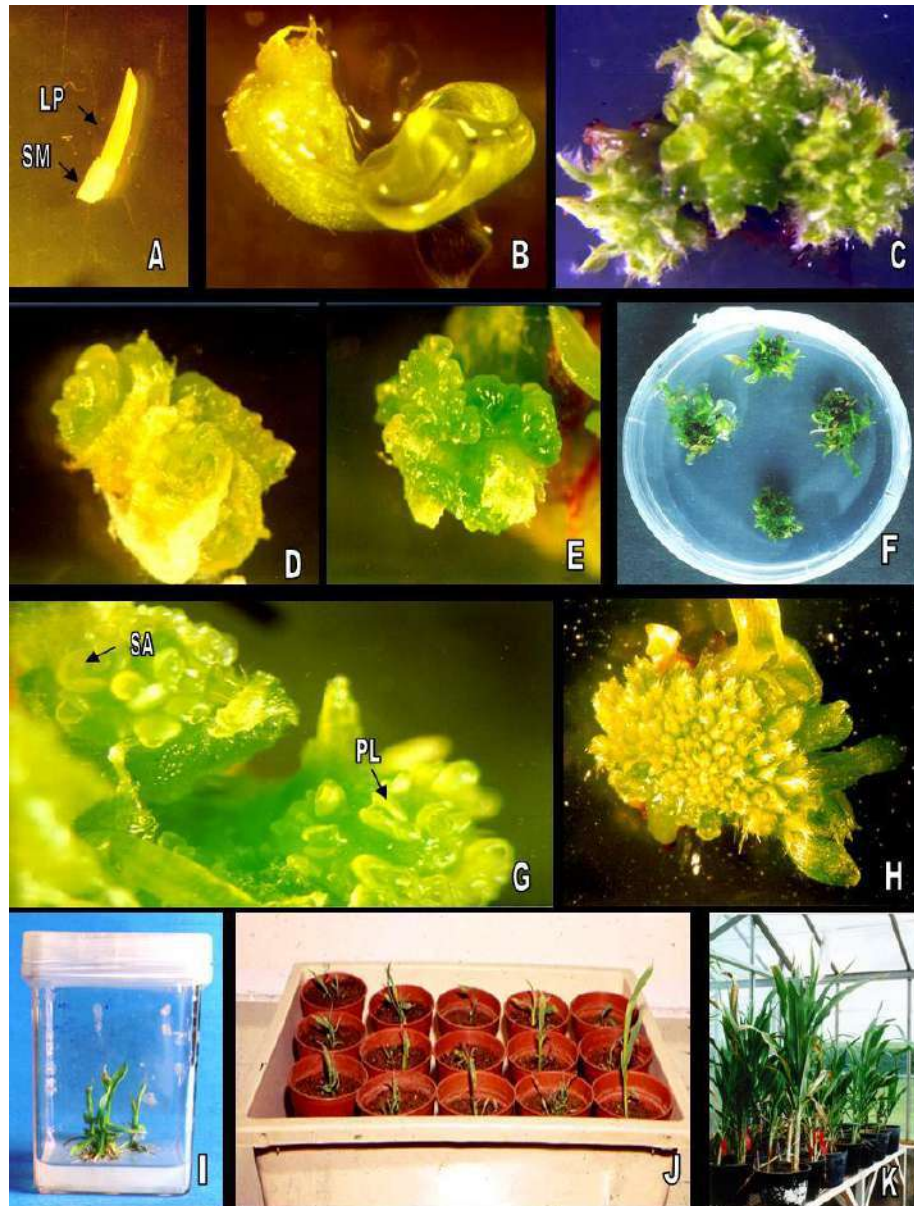

(A) One day old isolated shoot apices with primordial leaves *LP* = leaf primordia; *SM* = shoot meristem. (B) One- week old explant showing bulged meristem portion and expanded primordial leaves. (C) Three- week old meristematic mass showing multiple buds and leaf initials. (D) Individual buds (shown in Fig.1C) producing 2-8 translucent tissue strata. (E) Each of the tissue stratum giving rise to many somatic embryos. (F) Meristematic clumps showing differentiating buds. (G) Germinating somatic embryo's showing shoot apex (*SA*) surrounded by a pair of primary leaves (*PL*). (H) Differentiation of somatic embryos into plantlets. (I) Plantlets with well formed roots in magenta box. (J) Acclimatization of plantlets in the growth chamber. (K) Regenerated plants in greenhouse.

Figure 8. Indirect somatic embryogenesis in carrot

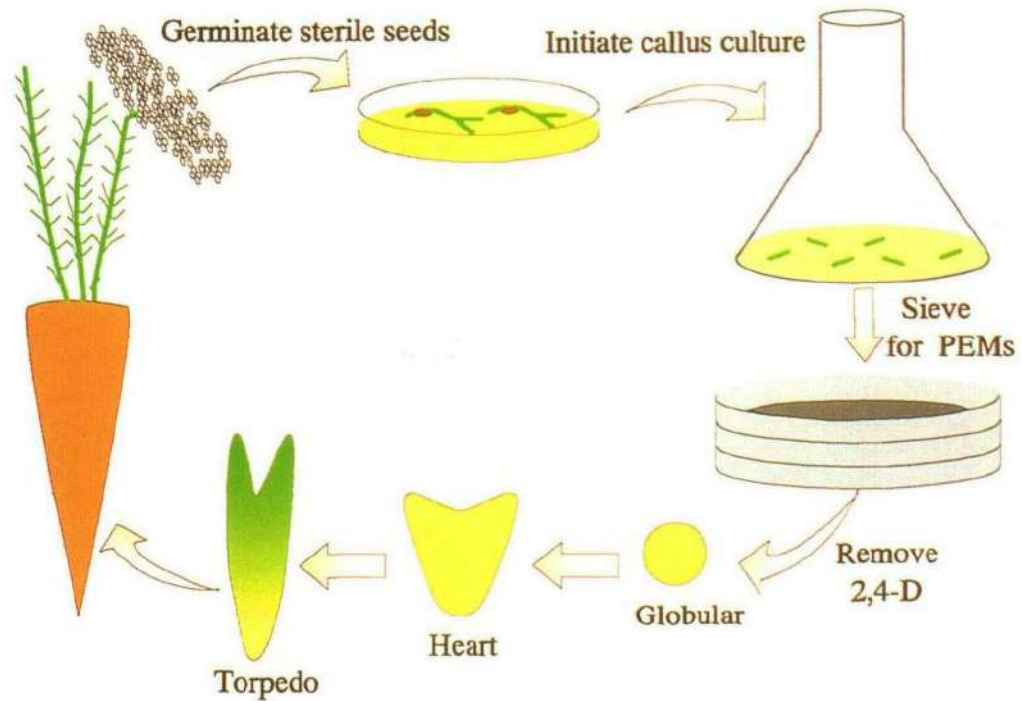

Once induction of embryogenic determined cells have been achieved, there appears to be no fundamental difference between indirect and direct somatic embryogenesis. In both processes, embryoids may arise from one or more of a group of determined cells. There are close homologies between direct and indirect embryogenesis and between single cell and multiple cell initiation of embryoids. The differences observed among these may be attributed to differences in the neighbouring cells and the mode of determination of embryogenic nature.

Questions

1. Cell differentiation in animals is

- a) **Irreversible**
- b) Reversible
- c) Both a & b
- d) None of the above

2. Cell differentiation in plants is

- a) Irreversible
- b) **Reversible**
- c) Both a & b
- d) None of the above

3. The inherent potentiality of a plant cell to give rise to a whole plant is described as

- a) Cellular totipotency
- b) **Morphogenesis**
- c) Organogenesis
- d) None of the above

4. For a differentiated cell, to express its totipotency, it should undergo dedifferentiation followed by redifferentiation

- a) Dedifferentiation
- b) Redifferentiation
- c) **Both a & b**
- d) None of the above

5. The phenomenon of a mature cell reverting to the meristematic state and forming undifferentiated callus tissue is termed as

- a) **Dedifferentiation**
- b) Redifferentiation
- c) Both a & b
- d) None of the above

6. The phenomenon of conversion of component cells of callus tissue to whole plant or plant organs is called as

- a) Dedifferentiation
- b) **Redifferentiation**
- c) Both a & b
- d) None of the above

7. The phenomenon of totipotency is demonstrated with the experiment involving

- a) Beetroot
- b) Onion
- c) **Carrot**
- d) None of the above

8. The phenomenon of morphogenesis depends on the factors like.....

- a) Polarity
- b) Differentiation
- c) Regeneration of individual cells
- d) **All the above**

9. concluded in "Organbildung im Pflanzenseichconcluded that the fate of a cell is a function of its position.

- a) **Vochting**
- b) Haberlandt
- c) Hanstein
- d) Klebs

10. Under *in vitro* conditions this can be achieved by

- a) *de novo* origin of organs
- b) *de novo* origin of embryos
- c) **Both a & b**
- d) None of the above

11. Organogenesis means genesis of organ(s) like

- a) shoots
- b) roots
- c) leaves and flowers
- d) **All the above**

12. The earliest report on induction of shoot organogenesis *in vitro* was by using a tobacco hybrid.

- a) **White**
- b) Nobecourt
- c) Skoog
- d) Miller

13. The first observation of root formation was reported by using carrot callus.

- a) White
- b) **Nobecourt**
- c) Skoog
- d) Miller

14. The regulatory mechanism ie., balance between auxin and cytokinin is recognized by.....

- a) White
- b) **Nobecourt**
- c) **Skoog & Miller**
- d) Murashigee

15. The relatively high level of auxin to cytokinin favoured during organogenesis

- a) **Root formation**
- b) Shoot formation
- c) Both root and shoot formation
- d) None of the above

16. The relatively high level of cytokinin to auxin favoured during organogenesis.

- a) Auxin
- b) Cytokinin
- c) **Gibberellic acid**
- d) None of the above

Nutritional requirements

The composition of medium for the tissue culture is the most important key factor in the successful culture of plant cells. The medium should be accurately defined of inorganic and organic chemical additives so as to provide i) the nutrients for the survival of the plant cells, tissues and organs under culture and ii) the optimal physical condition of pH, osmotic pressure, *etc.*

In the culture of plant cells formulating optimum type of medium favorable for *in vitro* culture was achieved many years ago. The **Knop's** (1865) mineral solution was the widely used medium by early investigators. **Gautherat** (1939) developed callus culture medium from **Uspenski** and **Uspenskaia** (1925) nutrient solution. A systematic study of mineral requirements of plant tissue and organs in culture was made by **Murashige** and **Skoog** (1962) followed by the scientists **Linsmaier** and **Skoog** (1965), **Vasil** and **Hildebrandt** (1966) and **Nitsch** and **Nitsch** (1969) resulting in several media to suit particular needs.

Nutrients

A standard basal medium consists of a balanced mixture of macronutrients and micronutrients (usually salts of chlorides, nitrates, sulphates, phosphates and iodides of Ca, Mg, K, Na, Fe, Zn and B, a carbon source, vitamins, phytohormones and organic additives. Among the above mentioned nutrients some are essential and some are optional. The essential components include inorganic nutrients and organic nutrients like carbohydrates besides phytohormones and vitamins, organic additives like natural extract and liquid endosperm are optional.

Inorganic salts

Inorganic nutrients of a plant cell culture are those required by the normal plants. The optimum concentration of each nutrient for achieving maximum growth rates varies considerably. The major elements are N, P, K, S, Mg and Ca. Other nutrients such as Co, Fe, B, Zn, Mo, Cu, I are microelements.

Macroelements

Nitrogen

Of all the mineral nutrients N plays a vital role in growth and differentiation of cultured tissues. The range of inorganic nitrogen varies from 25 mM to 60 mM according to the requirements. Nitrogen is generally supplied in the form of NH_4 along with NO_3 .

Ammonium ion as nitrogen source is usually unsuitable, probably because under such conditions the pH of the medium has a tendency to fall below 5 during culture, resulting in reduced availability of nitrogen. Cells can be grown with NH_4 as the sole N source when the medium is provided with organic acids such as malate, succinate, citrate or fumarate. Further, the concentration of $\text{NH}_4\text{-N}$ should not exceed 8 mM. Generally $\text{NO}_3\text{-N}$ can be used as a sole N source but often there is a beneficial effect if the media contains $\text{NH}_4\text{-N}$.

Phosphorus

Phosphorus is usually supplied in the form of phosphates. It is the primary buffering constituent in tissue culture media. Phosphorus levels greater than 2mM are often inhibitory to growth of tissues.

Potassium

The optimum concentration of K needed is 20 mM. At low nitrogen concentration presence of potassium enhances the formation of somatic embryos. The medium supplemented with potassium nitrate produces more embryos than the medium with ammonium nitrate.

Sulphur

Sulphur is provided in the form of sulphates. Besides, the sulphur containing amino acids like L-cysteine, L-methionine and glutathione are satisfactory sources for sulphur.

Calcium and Magnesium

The optimal concentration of Ca required is 3mM. An antagonism between Ca and Mg has been demonstrated and it was found that an increase in the concentration of one element increased the requirement for the other.

Microelements

The microelements viz., Fe, Mn, B, Zn, Mo, Cu, I and Co have a profound effect on growth of tissue *in vitro*. The availability of the iron is reduced at high pH due to precipitation. To avoid this, Fe is supplied as chelated EDTA complex. These elements produce toxic effect, if they are applied at higher level. A good growth of tissue can be achieved when the concentration of microelements was reduced to 10 per cent of the original level.

Organic nutrients

Carbohydrates

Carbohydrates are used as carbon sources. The standard carbon source is sucrose at a concentration of 2-5 per cent. Monosaccharides like glucose or fructose can also be used as carbon sources but are generally less suitable. Sucrose is the best source, since sucrose is dehydrolysed into usable sugars during autoclaving.

Vitamins

Vitamins are supplemented with medium to achieve the best growth of the tissues. Among the vitamins only thiamine HCL (B₁) seems to be universally required. Other vitamins are pyridoxine HCL (B₆), nicotinic acid (B₃) and calcium pantothenate (B₅). Specific requirement of each one varies with the plant species subject to culture.

Phytohormones

These are organic compounds, other than nutrients, which influence growth, differentiation and multiplication. They required in very minute quantity in the media. The requirement for these substances varies considerably with the tissue and it also depends on their endogenous level. There are many commercially available synthetic substances that mimics the PGR specific to certain species. Testing of various types, concentrations and mixtures of growth substances during the development of a tissue culture protocol for a new species is essential before using a new PGR in plant tissue culture.

There are different groups of PGRs commonly used in the media. They are auxins, cytokinins, gibberellins, ethylene and abscissic acid. Additional substances gaining recognition as hormones in plant tissue culture are: polyamines, jasmonates, salicylic acid and brassinosteroids.

1. Auxin

In nature, the hormones of this group are involved with elongation of stem, internodes, tropism, apical dominance, abscission, rooting etc. In tissue culture auxins have been used for cell division and root differentiation. The commonly used auxins in tissue culture are

1. Indole-3-acetic acid (IAA)
2. Indole-3-butyric acid (IBA)
3. Naphthalene acetic acid (NAA)
4. Dichlorophenoxyacetic acid (2, 4-D)

Auxins are usually dissolved in either ethanol or dilute NaOH.

2. Cytokinins

These hormones are essential for cell division, modification of apical dominance, shoot differentiation etc. In tissue culture media, cytokinins are incorporated mainly for cell division, differentiation of adventitious shoots from callus and organ & shoot proliferation.

Commonly used cytokinins are

1. Benzylamino purine (BAP)
2. Isopentenyl adenine (2-ip)
3. Furfurylamino purine (kinetin)
4. Zeatin

Cytokinins are generally dissolved in dilute HCl or NaOH.

Auxin - Cytokinin Interaction

1. High auxin and low cytokinin ratio: Initialize root formation, embryogenesis and callus formation.
2. Low auxin and high cytokinin ratio: Induce formation of adventitive or axillary shoots.
3. The auxin-cytokinin ratio is also essential for chloroplast formation and other processes.

Effect of different auxin and cytokinin concentration on tissue development



3. Gibberellins

Naturally occurring plant hormones involved in internode elongation, enhancement of flower, fruit and leaf size, germination and vernalization in plants. Among the 20 known gibberellins, GA₃ is used widely. Compared to auxins and cytokinins, gibberellins are used very rarely. They stimulate normal development of plantlets from *in vitro* formed adventitious embryos. They are soluble in cold water.

4. Ethylene

A gaseous plant hormone involved in fruit maturation, abscission, and senescence. All kinds of plant tissue cultures produce ethylene and the rate of production increases under stress conditions. Use of ethylene precursor (2-chloroethylphosphonic acid) in tissue culture may be promotory or inhibitory for the same process in different species. For example, it promoted somatic embryogenesis in *Zea mays* whereas the same process was inhibited in *Hevea brasiliensis*.

5. Abscisic acid

A plant hormone involved in abscission, enforcing dormancy and regulating early stages of embryo development. It is required for normal growth and development of somatic embryos and promotes morphogenesis.

6. Brassinosteroids

It promotes shoot elongation at low concentrations and strongly inhibits root growth and development. It also promotes ethylene biosynthesis and epinasty.

7. Jasmonates

Jasmonates are represented by jasmonic acid and it is a methyl ester. Jasmonic acid is considered to be a new class of plant growth substance. It inhibits many processes such as embryogenesis, seed germination, pollen germination, flower bud formation, chlorophyll formation. It is involved in differentiation, adventitious root formation, breaking of seed dormancy and pollen germination.

8. Polyamines

There is some controversy as to whether these compounds should be classified with hormones. They appear to be essential in growth and cell division.

9. Salicylic acid

It is thought to be a new class of plant growth substances. It promotes flowering, inhibits ethylene biosynthesis and reverses the effects of ABA.

Organic additives

Amino acids like glutamine, asparagine and nitrogen base like adenine are used as additives in tissue culture media. The organic acids citrate, malate, succinate and fumarate are used when the medium has nitrogen in ammoniacal form.

A wide variety of complex natural extracts like coconut water (liquid endosperm) tomato and orange juices is also used during media preparation. These complex substances possess a number of amino acids, vitamins, sugars, sugar alcohols, growth regulators and other unidentified substances with growth promoting qualities. However, these should be avoided because of their unknown and variable composition. Among the natural extract coconut water is widely used as a source of cytokinin and various amino acids.

Other complex substances often used in tissue culture media are: casein hydrolysate, yeast extract and malt extract. Potato extract is also used in China for cereal anther cultures.

Physical form of media

I. Solidified medium

Advantages

1. Explants are easily seen and recovered.
2. No Special aeration required.
3. Shoots grow more orderly.
4. Long term maintenance is possible.
5. Use of simple containers occupy little space

Disadvantages

1. Slower rate of multiplication.
2. Limited surface of explant is in contact with the medium.

II. Liquid medium

Advantages

1. Callus easily break up and shed as cells to establish a fine suspension.

2. Faster rate of multiplication
3. A greater surface of explants is in contact with medium.
4. Toxic metabolites will effectively be dispersed.

Disadvantages

1. Recovery is difficult.
2. Growth is disoriented.
3. Seeds would not germinate.
4. Protocorms and plantlets become brown and dry. Seeds submerged will show vitrification.

Commonly used tissue culture media

1. **MS** (Murashige and Skoog, 1962) and **LS** (Linsmaier and Skoog, 1972) media are used for regeneration of both monocots and dicots.
2. **B5** (Gamborg *et al.*, 1969) developed for culture of soybean cell suspensions but also has been effectively used for variety of plant regeneration. **B5** and its various derivatives have been valuable for cell and protoplast cultures.
3. **SH**: Schenk and Hildebrandt (1972) introduced this for culture of monocots and dicots. Widely used for legumes.
4. **WPM**: Lloyd and McCown (1980-1981). This is post MS media. WPM is increasingly used for propagation of Ornamental shrubs and trees in commercial labs.
5. **N6** was developed by Chu for cereal anther culture and also used for anther culture of other species.
6. In special cases, NN (Nitsch and Nitsch) was also used.

The physical form of a tissue culture medium, like the combination of nutrients is more important, since the uptake of nutrients by the tissues, their growth and development are dependent on it. To maintain the physical form of medium suitable for culturing, care should be taken to maintain the necessary (1) hydrogen ion concentration. (2) gelling agent and (3) osmotic pressure of the medium.

Hydrogen ion concentration (pH)

The pH of the medium is usually adjusted between 5.0 and 6.0 prior to the addition of agar and autoclaving. The extremes of pH should be avoided as this will block the availability of some of nutrients to the inoculum. A pH of 5.8 is found to be optimum for plant tissue

culture. Generally, pH higher than 6.0 give a very hard medium and a pH below 5.0 do not allow satisfactory solidification of agar. Further, pH in media changes during growth of plant tissues and this drift in pH is comparatively low in media with high salt concentration, because of their greater buffering capacity.

Gelling agents

Generally tissue culture media are solidified with any of the gelling agents. Agar is widely used for solidification of the medium. The optimum concentration of agar used ranges from 0.8-1.0 per cent (W/V). If the concentration of the agar is increased, the medium becomes hard and does not allow the diffusion of nutrient into the tissues. Gelatin, silica gel, acryl amide gel and starch copolymers are also used as substitutes for agar. Sometimes, the solid media will accumulate the toxic substances namely, oxidised, phenolic compounds released from tissue and hamper further growth of tissue. To absorb the toxic substances, 1 percent activated charcoal is added to the medium. One disadvantage of adding activated charcoal is that it would adsorb the growth regulators.

Liquid medium (the medium without any gelling agent) is suitable for suspension culture and it is superior to other media for the following reasons: 1) does not have impurities as in the agarified medium where the agar contains impurities, 2) aeration can be provided to the cells by keeping the suspensions under constant shakings and 3) toxic substances released from the tissues will not accumulate or localize; the substances get diluted. In liquid media cultures, filter paper bridges or glass wool can be used to support culture tissue.

Osmotic pressure

The cell cultured *in vitro* is mostly osmotically fragile and hence the osmotic pressure of the medium should be maintained at optimal level. This problem is serious one when liquid media are used. To adjust the osmotic pressure, stabilizers otherwise known as osmoticums *viz.*, sorbitol and mannitol (sugar alcohol) are used. These are non metabolisable sugars. The soluble sugar like sucrose, fructose, galactose, *etc.*, is also effective. The sucrose is added to the medium not only to provide energy but also to maintain a suitable osmolarity in the medium.

Several modifications have been made in the basic media evolved for various types of plant tissue cultures and the modifications are ever continuing processes in the field of plant

tissue culture. The reason behind this is that the selection of a particular culture medium for a particular species is difficult. Considering the difficulties the following approaches may be taken into consideration to identify a suitable medium for the work. 1) literature survey for work on similar objectives or near relative species and to try out the media in the reports, 2) experimentation with several of the well known media incorporating some variables and 3) conducting broad spectrum experiments involving most of the components (minerals, carbon source and phytohormones) with different treatments. The suitable combinations can be identified when the desired response is achieved.

Environmental factors influencing plant tissue culture

1. Genotype or variety of the plant material
2. Explant selection and its size.
3. Medium:
 - (i) Nutrients,
 - (ii) Growth regulators and
 - (iii) Other additives
4. Culture Environment:
 - (i) Temperature,
 - (ii) Relative Humidity (RH) and
 - (iii) Light

Questions

1. The mineral solution widely used by early investigators was

- a) **Knop's medium**
- b) MS medium
- c) White's medium
- d) None of the above

2. The medium in tissue culture should provide

- a) Nutrients for the survival of the plant cells, tissues and organs under culture
- b) Optimal physical condition of pH, osmotic pressure, *etc*
- c) **Both a & b**
- d) None of the above

3. The callus culture was first developed by

- a) Skoog
- b) White
- c) **Gautherat**
- d) None of the above

4. The systematic study of mineral requirements of plant tissue and organs in culture was made by

- a) Murashige and Skoog
- b) Vasil and Hildebrandt
- c) Nitsch and Nitsch
- d) **All the above**

5. The mineral nutrient that plays a vital role in growth and differentiation of cultured tissues is

- a) **N**
- b) P
- c) K
- d) All the above

6. Nitrogen is generally supplied in form.

- a) **NH₄**
- b) NO₃
- c) NO₂
- d) All the above

7. The range of inorganic nitrogen varies between in the tissue culture medium.

- a) **25 mM - 60 mM**
- b) 250 mM - 600 mM
- c) 2.5 mM – 6.0 mM
- d) 0.25 mM – 0.60 mM

8. Phosphorus levels greater than are inhibitory to growth of tissues.

- a) 2 mM
c) 200 mM
- b) 20 mM
d) 0.2 mM

9. The optimum concentration of K needed is

- a) 2 mM
c) 200 mM
- b) 20 mM**
d) 0.2 mM

10. At low nitrogen concentration presence of element enhances the formation of somatic embryos

- a) K**
c) Ca
- b) P
d) Mg

11. Sulphur is provided in the form of sulphates

- a) Sulphates**
c) Both a & b
- b) Sulphites
d) None of the above

12. The standard carbon source is

- a) Sucrose (2-5 per cent)**
c) Fructose
- b) Glucose
d) None of the above

13. The standard carbon source is

- a) Sucrose (2-5 per cent)**
c) Fructose
- b) Glucose
d) None of the above

14. Universally required vitamin in tissue culture medium is

- a) Thiamine HCL**
c) Nicotinic acid
- b) Pyridoxine HCL
d) Calcium pantothanate

15. Vitamin (s) used in tissue culture medium is/are

- a) Calcium pantothanate
c) Nicotinic acid
- b) Pyridoxine HCL
d) All the above

16. The commonly used auxins in tissue culture are

- a) IAA, IBA, NAA, 2,4 D**
- b) BAP, 2-ip, Kinetin, Zeatin

c) GA₃

d) All the above

17. The commonly used cytokinins in tissue culture are

a) IAA, IBA, NAA, 2,4 D

b) BAP, 2-ip, Kinetin, Zeatin

c) GA₃

d) All the above

18. The auxins are diluted in

a) Ethanol

b) Dilute NaOH

c) Both a & b

d) None of the above

19. The cytokinins are diluted in

a) Dilute HCl

b) Dilute NaOH

c) Both a & b

d) None of the above

20. In tissue culture auxins have been used for

a) Cell division and root differentiation

b) Differentiation of adventitious shoots from callus and organ & shoot proliferation

c) Normal development of plantlets from *in vitro* formed adventitious embryos

d) None of the above

21. In tissue culture cytokinins have been used for

a) Cell division and root differentiation

b) Differentiation of adventitious shoots from callus and organ & shoot proliferation

c) Normal development of plantlets from *in vitro* formed adventitious embryos

d) None of the above

22. In tissue culture gibberellins have been used for

a) Cell division and root differentiation

b) Differentiation of adventitious shoots from callus and organ & shoot proliferation

c) Normal development of plantlets from *in vitro* formed adventitious embryos

d) None of the above

23. High auxin and low cytokinin ratio favours

- a) **Initialize root formation, embryogenesis and callus formation** b) Induce formation of adventitive or axillary shoots
 c) Chloroplast formation and other processes d) None of the above

24. Low auxin and high cytokinin ratio favours

- a) Initialize root formation, embryogenesis and callus formation **b) Induce formation of adventitive or axillary shoots**
 c) Chloroplast formation and other processes d) None of the above

25. The auxin-cytokinin ratio is essential for

- a) Initialize root formation, embryogenesis and callus formation b) Induce formation of adventitive or axillary shoots
 c) Chloroplast formation and other processes **d) All the above**

26. The naturally occurring gibberellin is involved in

- a) Internode elongation b) Enhancement of flower, fruit and leaf size
 c) Germination and vernalization **d) All the above**

27. The gibberellins are soluble in

- a) Dilute HCl b) Dilute NaOH
c) Cold water d) Hot water

28. Ethylene is involved in

- a) Fruit maturation b) Abscission
 c) Senescence **d) All the above**

29. Abscissic acid is involved in

- a) Enforcing dormancy b) Abscission
 c) Regulating early stages of embryo development **d) All the above**

30. Abscissic acid is required for

- a) Normal growth b) **Promotes morphogenesis**
 c) Development of somatic embryos **d) All the above**

31. promotes ethylene biosynthesis and epinasty.

- a) **Brassinosteroids**
- b) Jasmonates
- c) Polyamines
- d) Salicylic acid

32. Jasmonic acid is a

- a) **Methyl ester**
- b) Ethyl ester
- c) Ether
- d) None of the above

33. The optimum pH of the tissue culture is

- a) **5.8**
- b) 6.0
- c) 4.0
- d) 7.0

34. The substitutes for agar are

- a) Gelatin
- b) Silica gel
- c) Acryl amide gel
- d) **All the above**

35. The osmoticums used in tissue culture medium are

- a) Sorbitol and mannitol
- b) Sucrose
- c) Fructose and galactose
- d) **All the above**

Techniques of *in vitro* cultures

Various terms are used to define the phenomenon in *in vitro* studies. For example differentiation, de-differentiation, re-differentiation, regeneration and morphogenesis are terms with overlapping meanings. To give a clear cut view for the usage of terms, the sharp differences among them exposed hereunder.

Differentiation: The term differentiation is used in many different senses in biology. In broad sense, it is defined as the process by which meristematic cells are converted into two or more types of cells, tissues or organs which are qualitatively different from each other.

De-differentiation: The term is used to denote the process of formation of unorganized tissues from the highly organised tissues.

Re-differentiation: The process of differentiation occurring in an undifferentiated tissue.

Regeneration: It is defined as the structuring of any part, which has been removed or physiologically isolated from the organism. In other words, genesis of an entire plant from cultured explants directly or *via* callus indirectly is called regeneration.

Morphogenesis

Attainment of biological organization or form is termed as morphogenesis. Under *in vitro* conditions this can be achieved by two routes: *de novo* origin of organs, either shoots or roots from the cultured tissues precisely termed as organogenesis and *de novo* origin of embryos with distinct root and shoot poles on opposite ends from the somatic cells or cells cultured *in vitro*, otherwise called as somatic embryogenesis. The historical background, achievements and the causes for the two routes are discussed below.

Organogenesis

In plant tissue culture, organogenesis means genesis of organs like shoots, roots, leaves, flowers, *etc.* The earliest report on induction of shoot organogenesis *in vitro* was by White (1939) using a tobacco hybrid; and the first observation of root formation were reported by Nobecourt (1939) using carrot callus. Till late 1950s, the basic regulatory mechanism underlying in organogenesis was not identified. Skoog and Miller (1957) were responsible to recognize the regulatory mechanism as a balance between auxin and cytokinin. As per their finding, a

relatively high level of auxin to cytokinin favoured root formation and the reverse favoured shoot formation. Using this concept, it has now become possible to achieve organogenesis in a large number of plant species by culturing explants, calli and cell suspension in a defined medium.

In organogenesis, the shoot or root may form first depending upon the nature of growth hormones in the basal medium. The genesis of shoot and root from the explants or calli is termed as caulogenesis (caulm = stem) and rhizogenesis (rhizo = root) respectively.

Organogenesis or de novo regeneration is referred to the development of organized structures such as shoots, roots, flower buds, somatic embryos etc., from cultured cells or tissues. *De novo* organogenesis leading to complete plantlet regeneration is a multistage process consisting of at least three distinct stages.

1. shoot bud formation,
2. shoot development and multiplication
3. rooting of developed shoots.

Caulogenesis is a type of organogenesis by which only adventitious shoot bud initiation takes place in the callus tissue. When organogenesis leads to root development, then it is known as *rhizogenesis*. Abnormal structures developed during organogenesis are called *organoids*. The localized meristematic cells on a callus which give rise to shoots and/or roots are termed as *meristemoids*.

Meristemoids are characterized as an aggregation of meristem-like cells. These can occur directly on an explant or indirectly via callus.

Thus, there are two kinds of organogenesis. A developmental sequence involving an intervening callus stage is termed '*indirect*' organogenesis:

Primary explant → *callus* → *meristemoid* → *organ primordium*

Direct organogenesis is accomplished without an intervening proliferate callus stage:

Primary explant → *meristemoid* → *organ primordium*

In vitro plant tissues may produce many types of primordia (adventitious buds and organs) including those that will eventually differentiate into embryos, flowers, leaves, shoots, and roots. These primordia originate *de novo* from a cellular dedifferentiation process, followed by initiation of a series of events that results in to an organ.

Types of cultures

Organ cultures: Culturing isolated organs or tissues such as roots, stem, or leaf in an artificial media under controlled conditions are known as **organ culture**. Depending on the type of organs or tissue used for establishing the culture, organ cultures are named accordingly. The following are the various types of organ culture and its specific purpose:

Seed culture: Increasing the efficiency of germination of seeds that are difficult to germinate *in vivo*, precocious germination by application of plant-growth regulators, and production of clean seedlings for explants or meristem culture.

Embryo culture: Overcoming embryo abortion due to incompatibility barriers, overcoming seed dormancy and self-sterility of seeds, and embryo rescue in distant (interspecific or intergeneric) hybridization where endosperm development is poor, shortening of breeding cycle, etc.

Ovary or ovule culture: A common explant for the initiation of somatic embryogenic cultures, for the production of haploid plants, overcoming abortion of embryos of wide hybrids at very early stages of development due to incompatibility barriers, and *in vitro* fertilization for the production of distant hybrids avoiding style and stigmatic incompatibility that inhibits pollen germination and pollen tube growth.

Anther and microspore culture: Production of haploid plants, production of homozygous diploid lines through chromosome doubling, thus reducing the time required to produce inbred lines, and for uncovering mutations or recessive phenotypes.

Explant culture

Explant culture is actually the tissue culture. Culturing of any excised tissue or plant parts such as leaf tissue, stem parts, cotyledon, hypocotyls, root parts, etc., is called explant culture. The primary purpose of explant culturing is to induce callus cultures or to regenerate whole plantlets directly from it without the formation of callus. Shoot apical meristem culture is an example, and its important uses are the following: Production of virus-free germplasm or plantlets, mass production of desirable genotypes, facilitation of exchange between locations (production of clean material), and cryopreservation (cold storage) or *in vitro* conservation of germplasm, etc., are the main purposes of meristem or shoot apex culture.

Callus culture

Callus represents an unorganized or undifferentiated mass of cells. They are generally composed of parenchymatous cells and usually undergo division. When an explant is cultured in a medium supplemented with sufficient amount of auxins, it starts producing mass of cells from the surface of the explant. The concentration of auxins required for each type of explant will be different and is mainly dependent on the physiological state of the explant tissue. Callus cultures can be maintained for a very long time by intermittent sub-culturing to a fresh medium. The callus cultures can be manipulated for different purposes by changing the hormone concentrations in the media. Callus cultures can be used for regeneration of plantlets, preparation of single cells or suspension cultures, or for protoplasts preparation. Callus cultures can also be used for genetic transformation studies. In some instances, it is necessary to go through a callus phase prior to regeneration via somatic embryogenesis or organogenesis. Callus cultures are suitable for the generation of useful somaclonal variants (genetic or epigenetic) and can be used for *in vitro* selection of cells and tissue variants.

Cell-suspension cultures

Single-cell cultures and suspension cultures can be established from callus cultures by transferring a piece of callus tissue into liquid medium and subjecting it to continuous shaking. The growth rate of the suspension-cultured cells is generally higher than that of the solid culture. The former is more desirable, particularly for the production of useful metabolites on a large scale. A piece of the callus is transferred to a liquid medium in a vessel such as an Erlenmeyer flask and the vessel placed on a rotary or reciprocal shaker. The culture conditions depend on plant species and other factors, but in general, the cells are cultivated at 100 rpm on a rotary shaker at 25°C. By subculturing for several generations, a fine cell suspension culture containing small-cell aggregates and single cells is established.

The time required to establish the cell-suspension culture varies greatly and depends on the tissue of the plant species and the medium composition. The cells in suspension are also used for a large-scale culture with jar-fermentors and tanks. The suspension cultures can be grown either as batch cultures or as continuous cultures for producing phytochemicals. Enzymatic methods can also be adopted for establishing a fine cell-suspension culture. This is based on the use of certain pectin digesting enzymes in the culture medium, such as pectinase or macerozyme. These enzymes act on the pectin, which joins two adjacent cells in plant tissues, so that the cells become independent and grow freely as single cells. The cell-suspension

cultures can be used for inducing somatic embryogenesis and the preparation of artificial seeds, induction of somatic mutation, and selection of mutants by screening the cells just like microbial cultures. The main application of plant cell-suspension cultures is that it can be used for the bioproduction of certain important phytochemicals or secondary metabolites by applying the principle of biochemical engineering. The suspension cultures can be cultivated in specially designed bioreactors known as **airlift bioreactors** for the **mass-cell cultures** for the production of plant secondary metabolites on industrial scale. Normal bioreactors with mechanical stirrer cannot be used in plant-cell cultures because it can result in the breaking of cells and thereby the cell viability can be drastically reduced. Whereas the airlift bioreactor can provide both stirring and air inflow to meet the high demand of oxygen. The cells can also be used for genetic transformation experiments to produce transgenic plants.

Protoplast cultures

Protoplasts are plant cells without cell walls. The cell wall can be removed with an enzymatic method. The cells may be from the leaf tissue or from any other part of the plant or may be the cells from the suspension cultures. These cells are incubated in an enzyme mixture consisting of cellulase, hemicellulase, and pectinase for a specific period of time. The enzyme mixture acts on the cell wall and is completely digested, so that the underlying cell membrane is exposed. This protoplast on culturing in a proper medium will regenerate its cell wall and becomes a normal cell and then can regenerate into a whole plant. The plant protoplasts can be used for various biochemical and metabolic studies and it can be used for the somatic cell fusion to create somatic hybrids. Fusion of aenucleated and nucleated protoplasts can result in a special type of somatic hybrids known as cybrids, in which there is no fusion of nucleus, but fusion in between the cytoplasm. Protoplasts can also be used for genetic transformation studies with biolistic methods, electroporation techniques, by PEG-mediated DNA transfer or by direct injection of DNA into the nucleus of the protoplast using micro-syringes.

Plant regeneration pathways

There are two methods of whole plant regeneration: **organogenesis** and **somatic embryogenesis**.

Organogenesis: This is a major path of regeneration that involves the differentiation of culture cells or callus tissue into organs such as shoot and roots. Plant regeneration through the formation of shoots and roots is known as plant regeneration through organogenesis. Organogenesis can occur directly from the explants depending on the hormonal combination of

the medium and the physiological state of the explants. Miller and Skoog demonstrated that the initial formation of roots or shoots on the cultured callus or explant tissue depends on the relative concentration of auxins and cytokinins in the culture media. Medium supplemented with relatively high auxin concentration will promote root formation on the explants and high cytokinin concentration will promote shoot differentiation. In tissue culture practices there may be three types of medium in relative combinations of auxins and cytokinins, which promote either the shoot formation or root formation or both simultaneously. In the latter case, you can get the complete plantlets, having both shoot and roots, which can be directly transferred to the pots in the greenhouse. Whereas in other cases, after the formation of shoots, individual shoots are transferred to the rooting medium, which promote root formation. The rooted plantlets can be transferred to a greenhouse for acclimatization. Plant regeneration through organogenesis is commonly used for mass multiplication, for micropropagation, and for conservation of germplasm at either normal or subzero temperatures (cryopreservation).

Somatic embryogenesis

This is another major path of regeneration and development of plantlets for micropropagation or mass multiplication of specific plants. The cells, under a particular hormonal combination, change into the physiological state similar to zygotes (somatic zygotes) and follow an embryonic path of development to form somatic embryos. These somatic embryos are similar to normal embryos (seed embryos) developed from zygotes formed by sexual fertilization. The somatic embryos can develop into a complete plant. Since somatic embryos can germinate into a complete plant, these can be used for the production of artificial seeds. Somatic embryos developed by tissue or cell cultures can be entrapped in certain inert polymers such as calcium alginate and used as artificial seeds. Since the production of artificial seed is amenable to mechanization and for bioreactors, it can be produced in large numbers.

Embryogenesis

Embryos have been classified into two categories: zygotic embryos and non-zygotic embryos.

Zygotic embryogenesis

Embryos developing from zygotes (resulting from regular fusion of egg) are called as *zygotic embryos* or often simply *embryos*.

Non-zygotic embryogenesis

Usually non-zygotic embryos are formed by cells other than the zygote. E.g. *Parthenogenetic embryos* - formed from unfertilized eggs or a fertilized egg without karyogamy. *Androgenetic embryos* – formed from microspores, micro-gametophytes or sperm. *Somatic embryos* (also called as embryoids, accessory embryos, adventitious embryos and supernumerary embryos) – formed by somatic cells either *in vivo* or *in vitro*.

A somatic embryo is an embryo derived from a somatic cell, other than zygote, usually on *in vitro* culture. The process of somatic embryo development is called as *somatic embryogenesis*.

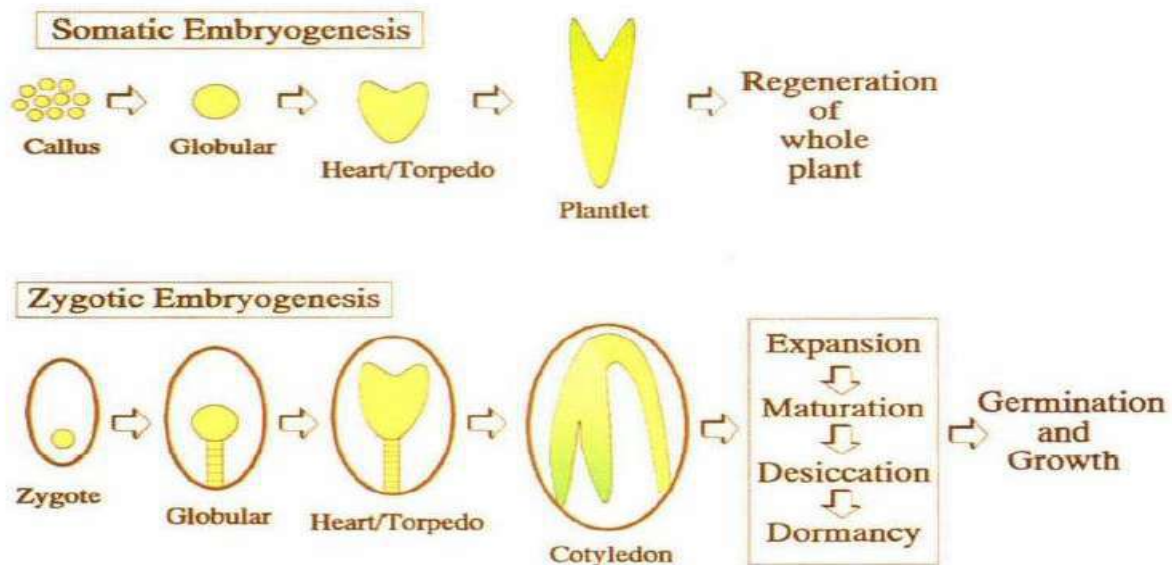

Stages in development of somatic embryoids

Plant regeneration via somatic embryogenesis for many species can be divided into two phases: 1. Selection and induction of cells with embryogenic competence, 2. Development of these cells into embryos.

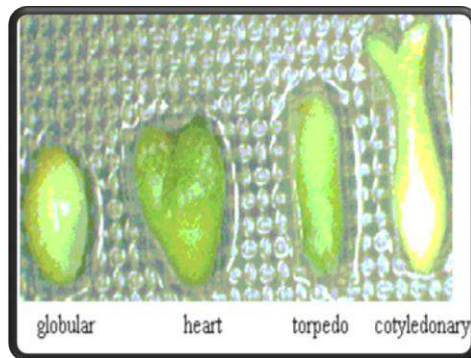

Somatic embryos generally originate from single cells which divide to form a group of meristematic cells. Usually, this multi-cellular group becomes isolated by breaking cytoplasmic connections with the other cells around it and subsequently by cutinization of the outer walls of this differentiating cell mass. The cells of meristematic mass continue to divide to give rise to *globular* (round ball shaped), *heart-shaped*, *torpedo* and *cotyledonary* stages (Figures). Somatic embryo genesis begins with active division of cells which leads to increase in size but retains the spherical shape. At this stage the primary meristem (protoderm, ground meristem and procambium) becomes visible. Following this stage, the callus continues to divide and differentiate into a heart-shaped embryo, with initiation of cotyledon primordia. As the cotyledon develops the embryo passes into the torpedo-shaped stage. The cells inside the cotyledonary ring divide to form shoot and root apical meristem and procambium differentiation takes place. In general, the essential features of somatic embryo development, especially after the globular stage, are comparable to those of zygotic embryo.

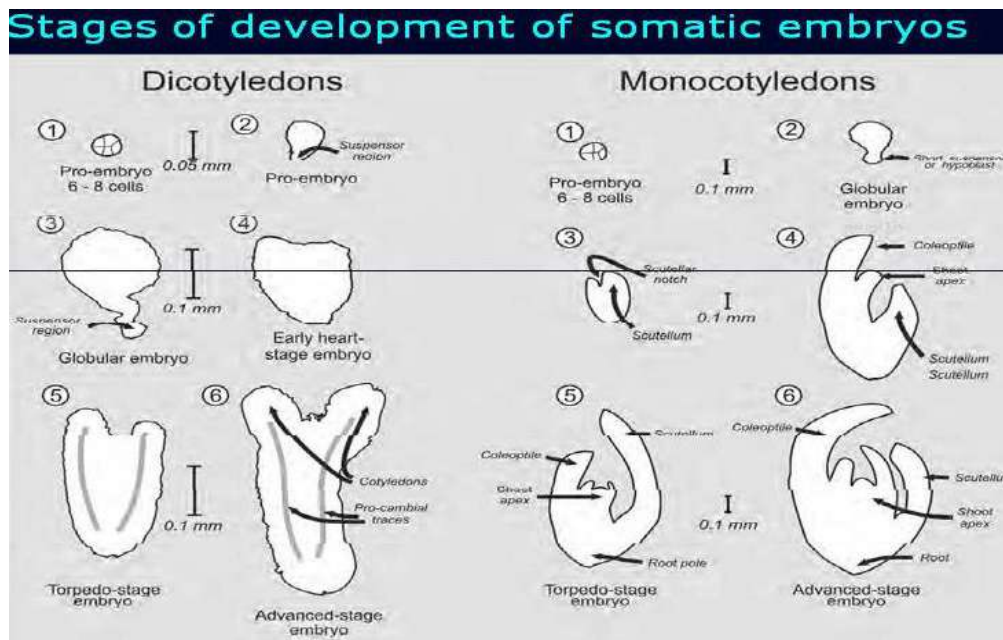

Somatic embryogenesis leads to the production of a bipolar structure containing in root/shoot axis (radicle/plumule) with a closed independent vascular system. The radicular end is always sticks out from the cell mass. In contrast, a shoot bud is monopolar as it does not have a radicular end.

Somatic embryos show abnormal developmental features, e.g. 3 or more cotyledons, bell-shaped cotyledon, larger size etc.; these problems are often overcome by the presence of ABA or a suitable concentration of mannitol. In some species normal looking somatic embryos are formed but they fail to germinate; at least some somatic embryos do not germinate in most of the cases.

As mentioned before, these embryos can occur directly on an explant or indirectly *via* callus. The somatic embryos regenerating from explant or callus are termed as *primary somatic embryos*. In many cases, somatic embryos regenerate from the tissues of other somatic embryo or the parts of germinating somatic embryo. Such somatic embryos are called as *secondary somatic embryos* (and the process is called as *secondary embryogenesis* or *recurrent embryogenesis*).

Additional readings.....

Factors affecting somatic embryogenesis

1. *Growth regulators*: In most species, an auxin is essential for somatic embryogenesis. The auxin causes dedifferentiation of the explant which begins to divide. In carrot, small compact cells divide asymmetrically and their daughter cells stick together to produce cell masses called *proembryogenic masses* or *embryogenic clumps* or '*proembryogenically determined cells*' (*PEDC*). In the presence of auxins, the embryogenic clumps grow and break up into smaller cell masses which again produce embryogenic clumps. But when the auxin is either removed or reduced and cell density is lowered, each embryogenic clump gives rise to few to several somatic embryos. Some glycoproteins produced by totipotent cells are secreted into the medium; when these proteins are added into the culture medium they speed up the process of acquisition of totipotency. A class of proteins, called arabinogalactan proteins (90% carbohydrates with a protein backbone) induces somatic embryo regeneration in undifferentiated carrot cells, indicating their role in this process. Auxins promote hypermethylation of DNA which may have a role in totipotency acquisition. In alfalfa, recurrent cycles of somatic embryogenesis- *secondary embryogenesis* or *recurrent embryogenesis* - occur in growth regulator free medium and each somatic embryo can give rise to about 30 somatic embryos.
2. *Sucrose*: When embryogenic clumps transferred to an appropriate medium, somatic embryo proceeds from globular, heart-shaped, torpedo to cotyledonary stages. This is called as somatic

embryo development phase. In most species, somatic embryos begin to germinate immediately after the cotyledonary stage, and this is termed as somatic embryo conversion. But the plantlets will be very weak. Therefore, the somatic embryos are subjected to maturation phase. In this phase, somatic embryos do not grow but undergo biochemical changes to become more sturdy and hardy. This is achieved by culturing them on a high sucrose medium or in presence of a suitable concentration of ABA or by subjecting them to desiccation (usually this is achieved by enclosing somatic embryos in a sterile, sealed, empty Petri dishes). This improves the somatic embryo conversion by several folds.

3. *Nitrogen source*: The form of nitrogen has marked effect on somatic embryogenesis. In carrot, NH_4^+ is essential during somatic embryo induction, while somatic embryo development occurs on a medium containing NO_3^- as the sole nitrogen source. The yield of alfalfa somatic embryo has considerably increased when amino acids such as proline, alanine, arginine and glutamine were added to the medium.
4. *Genotype of explant*: Explant genotype may determine the regeneration of somatic embryo. Of the 500 varieties of rice screened, 19 showed 65-100% embryogenesis, 41 showed 35-64% embryogenesis and the remaining 440 cultivars were less efficient in regeneration. These genotypic variations could be due to endogenous levels of hormones. In wheat, major and regulatory genes affecting regeneration were mapped on 2A, 2B and 2D. Variation for regeneration ability is highly additive and heritable in maize, rice and wheat. But in barley and alfalfa, dominance seems to be more important. Mitochondrial genome has also had an influence on regeneration (e.g. wheat). It has been shown that a loss of an 8 kb mitochondrial DNA segment in the non-embryogenic cells played a special role in the ability of dedifferentiated cells to regenerate. The success in obtaining regenerating cultures of several recalcitrant species (cereals, grain legumes and forest tree species) has been possible largely due to explant selection rather than media manipulation. Immature zygotic embryos have proved to be the best explant to raise embryogenic cultures of recalcitrant plants. However, cotyledons from somatic embryos of soybean gave considerably higher embryogenic response than those from zygotic embryos.

Other factors: Polyamines (putrescine, spermidine and spermine) are required for embryo development *in vivo or in vitro*. High K^+ levels and low dissolved O_2 levels promote somatic embryo regeneration in some species. The need for reduced dissolved oxygen could be

substituted by the addition of ATP to the medium, suggesting that, probably, oxygen tension enhanced the level of cellular ATP. In *Citrus*, some volatile compounds like ethanol inhibit somatic embryo regeneration.

Miscellaneous factors:

- a) Culture environment
- b) Bacterial compounds or contamination during tissue culture process.
- c) Electric stimulation: Stimulation of shoot bud differentiation in wheat, tobacco and alfalfa callus culture was achieved by exposure to mild electric field (0.02 V).

Large scale production of somatic embryos:

As the multiplication of embryogenic cells and the subsequent development of somatic embryos can occur in liquid medium, somatic embryogenesis offers a potential system for large scale plant propagation in automated bioreactors, with low labour inputs. For mass production of somatic embryos in bioreactors, callus is initiated on a semi-solid medium. Pieces of undifferentiated or embryogenic callus are transferred to liquid medium in small flasks and agitated in shaker. After a few cycles of multiplication in flasks, the embryogenic suspension may be filtered through a sieve of suitable pore size and proembryogenic masses (PEM) or globular embryos transferred to the bioreactor flask. Since the somatic embryos are individually propagules, a 2-5 litre bioreactor with a production capacity of 10-100 X 10³ embryos should be sufficient for commercial micropropagation (Figure).

Difference between shoot buds and somatic embryos

Characteristics	Shoot bud	Somatic embryo
Origin	Many cells; usually superficial	Single cell, superficial
Polarity	Unipolar; only the shoot pole present	Bipolar; both shoot and root poles present
Vascular connection with callus/explant	Present; vascular strands connected with those present in callus/explant	Absent; there is no vascular connection with callus/explant
Separation from callus/explant	Not easily separated unless cut off.	Easily separated since the radicular end is cutinized.

Events during organogenesis

It is a general rule that the organ formation would be through a process of differentiation in the undifferentiated mass of parenchyma. Most of the parenchymatous cells are highly vacuolated and with inconspicuous nuclei and cytoplasm, sometimes with lignification. In this group of cells, regions showing random cell division would occur, leading to radial files of differentiated tissues. These scattered cell division regions would form regions of high mitotic activity resulting in the formation of meristematic centres, otherwise termed as meristemoids. These meristemoids may be either on the surface of the calli or embedded in the tissue. Continued cell division in these meristemoids would produce small protruberences on the surface of the calli, giving nodular appearance to the tissues. From the meristemoids, the primordia of organs by repeated mitotic activity form either shoot or root. This was discovered by Torrey in 1966.

The meristemoids consist of a spherical mass of small isodiametric meristematic cells with dense cytoplasm and a high nucleo-cytoplasmic ratio. Normally, callus tissues accumulate starch and other crystals before organogenesis, but the substances disappear during meristemoid formation. During the initial stages of meristemoid formation, the cytoplasmic protrusions enter the vacuoles thus distributing the vacuoles around the periphery of each cell or dispersed throughout the cytoplasm. The nucleus is in the centre with maximum possible size. Thus cells in the meristemoids resemble the cells of highly active meristems in an intact plant.

Embryogenesis

An embryo is defined as a plant in its initial stage of development. Each embryo possesses two distinct poles, one to form root and the other shoot, and is the product of fusion of gametes. In some plant species, embryos are produced without the fusion of gametes and termed as asexual embryogenesis or adventitious embryony.

In an intact plant this type of embryogenesis may occur in sporophytic tissues like integuments and nucellar tissues or from unfertilized gametic cells. Apart from the normal course of embryo formations *viz.*, zygotic embryogenesis and adventitious embryony, instances of embryo formations from the tissues cultures *in vitro* were reported. This phenomenon termed as somatic embryogenesis was first observed by Steward and his co-workers (1958) in suspension cultures of carrot followed by Reinert (1959). Since then, a number of reports of embryo formation have been published.

Somatic embryogenesis or embryogenesis *in vitro* produces embryo like structures resembling the zygotic embryos in structure and morphogenetic potential. Despite this resemblance, the ontogeny of an embryo like structure from somatic cell differs from that of zygotic embryo, where the origin is from a single cell.

Embryoid is generally used to denote the embryo like structure from cultured tissues. These embryoids possess bipolarity, no vascular connection with the mother tissue and origin from a single cell or a group of cells.

Events during embryogenesis

In 1959, Reinert made the remarkable claim that following a succession of changes of the nutrient media, root derived callus tissue of *Daucas carota* produced normal bipolar embryos. The changes made or observed in the nutrient medium were as follows: maintenance of callus in White's medium with high level of auxin (IAA at 10 mg/litre) and subculturing of callus for several months on White's basal medium with additives like vitamins, amino acids, amides and purines. As a result of these manipulations, the calli showed small protruberences on the surface. Histological sections of these calli showed centres of organised development. These tissues with organised centres on transfer to auxin lacking but coconut milk containing medium produced embryoids and from embryoids, whole plants.

Theories on embryogenesis:

Several theories have been proposed to explain the phenomenon of somatic embryogenesis, of which the following are considered important.

Cell isolation theory: Steward and his co-workers proposed this theory in 1964. According to them, the embryo producing cells are isolated from the neighbouring cells in a cell mass. The isolation of cells, favours the embryogenesis. The isolation of cell may be induced by the constraints in the surrounding cells, due to physical and physiological separation of cells. In most cases, the connection of plasmodesmata was severed. But this generally appears to be secondary to the induction process.

Differentiation theory: This theory states that the embryos would not be produced from the differentiated cells of the explants. The cells of explants have to undergo de-differentiation to form callus. Then the cells of callus will produce embryos. In other words, de-differentiation in cells is a prerequisite for the production of somatic embryos *in vitro*. That the embryos can be formed directly from the epidermal cells of the stem or hypocotyl indicate the possibility of

embryo formation without de-differentiation. The need for differentiation depends on the explant material used during primary culture. Epidermal cells of the stem, hypocotyl and young embryos may begin embryo development without going through a callus stage, while cortical cells and cells of xylem and phloem explants require de-differentiation. This theory was proposed by Halperin in 1970.

36

Intercellular communication and cytodifferentiation theory: According to this theory, cytodifferentiation in cells due to intercellular communication induces embryo formation. The cytodifferentiation is regulated by diffusion gradients of nutrients, endogenous plant growth regulators and gaseous factors like O₂, CO₂ and ethylene. The changing microclimate in the culture environment affects intercellular communication and in turn cytodifferentiation. This concept was proposed by Street (1973).

Explant physiology and culture environment theory: This concept was developed by Street in 1976. He is of the view that the embryogenesis is a dependent phenomenon on the explant and the culture environment. Explants like flower buds, young embryos and parts of young seedling are most responsive to produce somatic embryos, but not from those of mature plants. Apart from the explant physiology, culture environment is also a factor influencing the embryogenesis. For example, highly embryogenic callus culture can be maintained non-embryogenic if the medium is supplemented with high level of auxin and the same may be induced to produce embryos when transferred to auxin free medium.

Pre-determination theory: This was proposed by Tisserat *et al.* (1979). It states that the embryo production potential is pre-determined phenomenon in the cells and the *in vitro* culture provides the opportunity for embryogenesis. In other words, embryogenesis from a cell is an inherent one which is facilitated to produce embryos by optimal culture environment.

Pre and induced embryogenic determined cell theory: Though the embryogenesis is pre-determined one there are instances of non-formation of embryos directly from the explants. In these cases, an intervening callus stage comes between the primary explant and the embryos. The cells in the calli are induced to produce embryos by the manipulation of medium with relevant growth regulator. Based on this, the above theory was proposed by Sharp and his co-workers. According to this theory, there are two types of embryogenic cells: pre-embryogenic determined cells (PEDC) and induced embryogenic determined cells (IEDC).

In pre-embryogenic determined embryogenic cells, embryogeny is determined prior to mitosis while induced embryogenic determined cells the embryogeny is induced by providing suitable mitogenic substance i.e., the embryogeny is induced in the cells of callus by the application of plant growth regulators. Thus in the callus, embryogenic precursor cells or embryogenic mother cells are formed which then develop into embryogenic cells. Later these cells undergo polarised cell divisions typical of normal embryogenesis by forming globular, heart and torpedo shaped embryos.

Patterns of embryogenesis

Two general patterns of embryogenesis *in vitro* are identified:: Origin of embryos directly from the tissue cultured *in vitro* (direct embryogenesis) and origin of embryos *via* callus stage (indirect embryogenesis) .

Table. Differences between direct and indirect embryogenesis

Direct embryogenesis	Indirect embryogenesis
Embryos form from the explants directly	Embryos arise from the callus induced from the explants
A promoting substance to induce the embryo formation is needed	Auxin is need to induce callus, and cytokinin is needed to induce differentiation
The embryogenic nature of a cell is predetermined	The embryogenic nature of a cell is induced in the culture
The origin of embryos mostly from individual cells; sometimes from a group of cells	The origin may be either from single cells or from a group of cells called pro-embryonal complex

Questions

1. The process by which meristematic cells are converted into two or more types of cells, tissues or organs which are qualitatively different from each other is
a). Differentiation b). De-differentiation c). Re-differentiation d). Regeneration
2. Term is used to denote the process of formation of unorganized tissues from the highly organised tissues is
a). Differentiation **b). De-differentiation** c). Re-differentiation d). Regeneration
3. The process of differentiation occurring in an undifferentiated tissue
a). Differentiation b). De-differentiation **c). Re-differentiation** d). Regeneration
4. Genesis of an entire plant from cultured explants directly or *via* callus indirectly is called regeneration
a). Differentiation b). De-differentiation c). Re-differentiation **d). Regeneration**
5. Attainment of biological organization or form is termed as
a). Differentiation b). De-differentiation c). Re-differentiation **d). Morphogenesis**
6. Morphogenesis can be achieved by
a). *de novo* origin of organs b). *de novo* origin of embryos
c). Both a and b d). None of the above
7. The earliest report on induction of shoot organogenesis *in vitro* was
a). White b). Nobecourt c). Skoog d). Miller
8. The earliest report on induction of root organogenesis *in vitro* was
a). White **b). Nobecourt** c). Skoog d). Miller
9. The induction of shoot organogenesis *in vitro* was achieved primarily in
a). tobacco b). carrot c). Both a and b d). None of the above
10. The induction of root organogenesis *in vitro* was achieved primarily in
a). tobacco **b). carrot** c). Both a and b d). None of the above
11. A developmental sequence involving an intervening callus stage is termed

- a). **'indirect' organogenesis** b). *'direct' organogenesis*
c). Morphogenesis d). None of the above

12. Abnormal structures developed during organogenesis are called

- a). **Organoids** b). Meristemoids c). Both a and b d). None of the above

13. The localized meristematic cells on a callus which give rise to shoots and/or roots are termed as

- a). Organoids **b). Meristemoids** c). Both a and b d). None of the above

14. Seed culture is used for

- a). To increase the efficiency of germination of seeds b). Precocious germination by application of PGRs
c). Production of clean seedlings for explants or meristem culture **d). All the above**

15. Embryo culture is used for

- a). To overcome embryo abortion due to incompatibility barriers b). To overcome seed dormancy and self-sterility of seeds
c). Embryo rescue in distant hybridisation **d). All the above**

16. Ovary or ovule culture is used for

- a). Initiation of somatic embryogenic cultures b). Production of haploid plants
c). To overcome abortion of embryos of wide hybrids **d). All the above**

Micropropagation

Multiplication of genetically identical copies of a cultivar by asexual reproduction is called *clonal propagation*. In nature, clonal propagation occurs by apomixis (seed development without meiosis and fertilization) and/or vegetative propagation (regeneration of new plants from vegetative parts). Tissue culture has become popular method for vegetative propagation of plants. Aseptic method of clonal propagation is called as *Micropropagation* and it offer the advantage of large number of true-to-type plantlets can be produced with relatively short time and space from a single individual. It is the fact that micropropagation is the only commercially viable method of clonal propagation of most of the horticultural crops. E.g. Orchids.

Explants used in micropropagation

Different kinds of explants were used in micropropagation. For example, in case of orchids, shoot tip (*Anacamptis pyramidalis*, *Aranthera*, *Calanthe*, *Dendrobium*), axillary bud (*Aranda*, *Brassocattleya*, *Cattleya*, *Laelia*), inflorescence segment (*Aranda*, *Ascofinetia*, *Neostylis*, *Vascostylis*), lateral bud (*Cattleya*, *Rhynocostylis gigantean*), leaf base (*Cattleya*), leaf tip (*Cattleya*, *Epidendrum*), shoot tip (*Cymbidium*, *Dendrobium*, *Odontioda*, *Odontonia*), nodal segment (*Dendrobium*), flower stalk segment (*Dendrobium*, *Phalaenopsis*) and root tips (*Neottia*, *Vanilla*) are being used in micropropagation.



Different explants

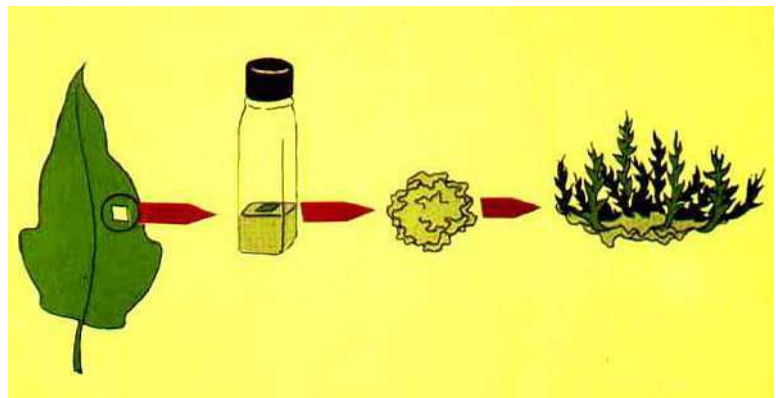

Differentiation of shoots directly from callus

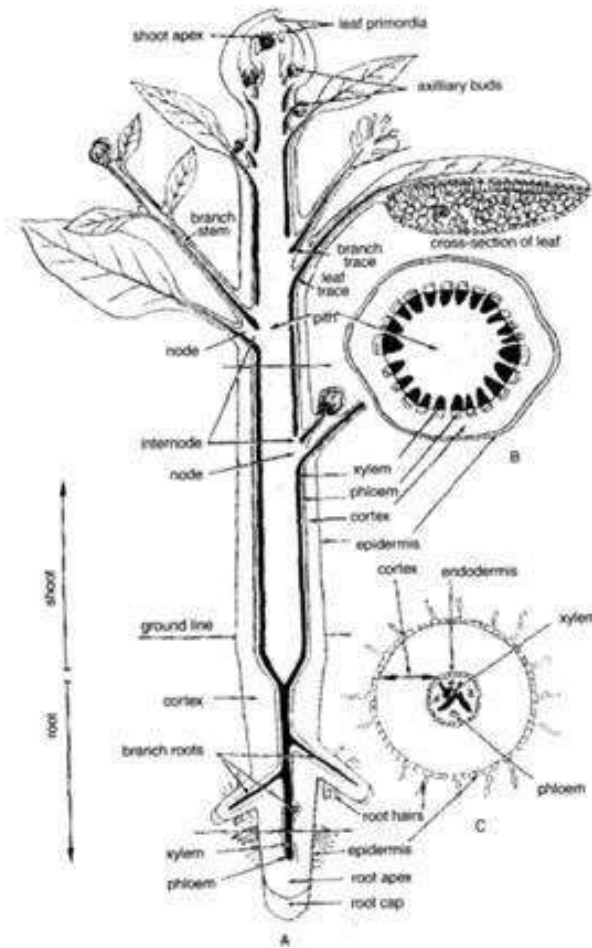

A. The principle organs and tissues of the body of a seed plant; B. Cross-section of stem; C. Cross-section of root. Apical or axillary buds are good sources of explants

Stages in micropropagation

Micropropagation generally involves five stages. Each stage has its own requirements.

Stage 0: Preparative stage

This stage involves the preparation of mother plants to provide quality explants for better establishment of aseptic cultures in stage 1. To reduce the contamination problem in the subsequent stages, mother plant should be grown in a glasshouse and watered so as to avoid overhead irrigation. This will also reduce the need for a harsh sterilization treatment. Stage 0

also includes exposing the stock plants to suitable light, temperature and growth regulator treatments to improve the quality of explants. In the case of photosensitive plants it may be possible to obtain suitable explants throughout the year by controlling photoperiod in the glasshouse. For example, red-light treated plants of *Petunia* provided leaf explants which produced up to three times as many shoots as did the explants from untreated plants.

Stage 1. Initiation of culture

1. **Explant:** The nature of explant to be used for *in vitro* propagation is governed by the method of shoot multiplication. For enhanced axillary branching, only the explants which carry a pre-formed vegetative bud are suitable. When the objective is to produce virus-free plants from an infected individual it becomes necessary to start with sub-millimeter shoot tips. If the stock is virus-tested or virus eradication is not necessary, then the most suitable explant is nodal cuttings. Small shoot-tip explants have a low survival rate and show slow initial growth. Meristem tip culture may also result in the loss of certain horticultural characteristics which are controlled by the presence of virus, such as the clear-vein character of the Geranium cv. Crocodile. Generally, the clear vein character is transmitted in petiole-segment culture but not in shoot-tip culture.
2. **Sterilization:** Special precautions need to be taken when explants are derived from field-grown materials, which is often necessary in cloning an elite tree. In such cases an ideal approach would be to take cuttings from the selected plant and grow them in greenhouse. Discarding the surface tissues from plant materials while preparing the explants also minimizes the loss of cultures due to microbial contamination.
3. **Browning of medium:** A serious problem with the culture of some plant species is the oxidation of phenolic compounds leached out from the cut surface of the explant. It turns the medium dark brown and is often toxic to the tissues. This problem is common with the adult tissues from woody species.

3. Stage 2. Multiplication

This is the most crucial stage since it is the point at which most of failures in micropropagation occur. Broadly three approaches have been followed to achieve *in vitro* multiplication.

1. **Through callusing:** The potentiality of plant cells to multiply indefinitely in cultures and their totipotent nature permit a very rapid multiplication of several plant types. Differentiation of plants from cultured cells may occur via shoot-root formation (organogenesis) or somatic embryogenesis. Somatic embryogenesis is most appealing from a commercial angle. A somatic embryogenesis system once established lends itself to better control than organogenesis. Since somatic embryos are bipolar structures, with defined root and shoot meristems, the rooting stage required for microshoots gets eliminated. Above all, somatic embryos being small, uniform and bipolar are more amenable to automation at the multiplication stage and for field planting as synthetic seeds, offering cost advantages from labour savings, can also be stored through cold storage, cryopreservation or desiccation for prolonged periods. These characteristics make somatic embryogenesis potentially a less expensive and flexible system for micropropagation. The most serious objection against the use of callus cultures for shoot multiplication is the genetic instability of their cells.

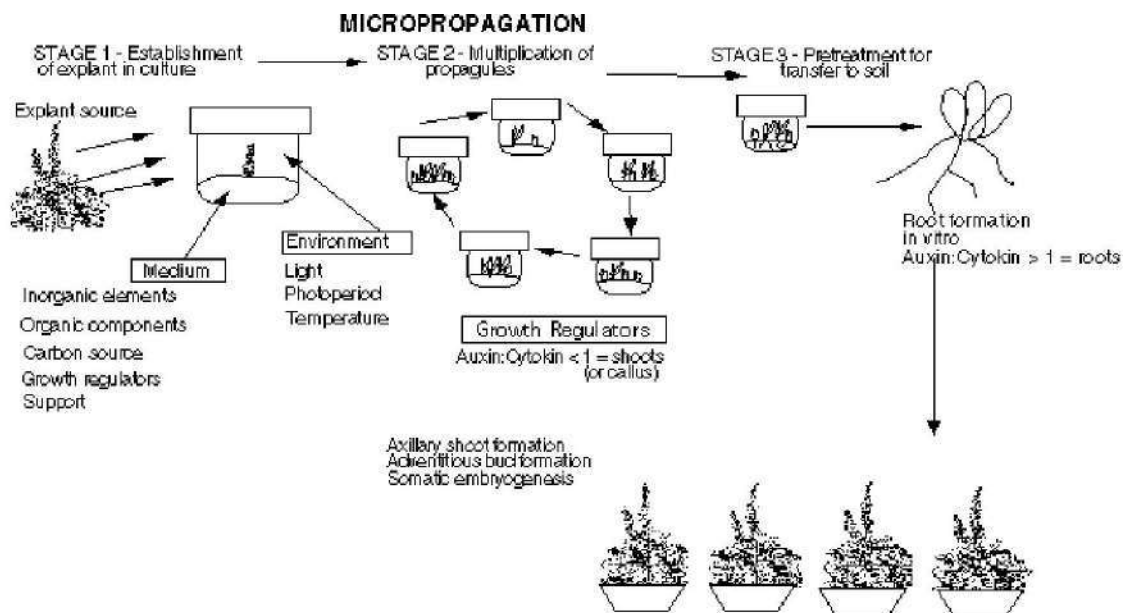

2. **Adventitious bud formation:** Buds arising from any place other than leaf axil or the shoot apex are termed adventitious buds. The shoots differentiated from calli should also be treated as adventitious buds. In many crops, vegetative propagation through adventitious bud formation from root (blackberry, raspberry) and leaf (*Begonia*, *Crassula*) cuttings is standard horticultural practice. In such cases the rate of adventitious bud development can be considerably enhanced under culture conditions. For most bulbous plants (e.g. Lilley) adventitious bud formation is the most important mode of multiplication and the best

explants are obtained from bulb scales. A serious problem may arise when this method of propagation is applied to varieties which are genetic chimeras. Adventitious bud formation involves the risk of splitting the chimeras leading to pure type plants. For example, in variegated geranium cv. Mme Salleron, the chimera is perpetuated in meristem culture but broken down in petiole culture.

- 3. Enhanced axillary branching:** In cultures the rate of shoot multiplication by enhanced axillary branching can be substantially enhanced by growing shoots in a medium containing a suitable cytokinin at an appropriate concentration with or without auxin. Due to continuous availability of cytokinin, the shoots formed by the bud, present on the explant, develops axillary buds which may grow directly into shoots. This process may be repeated several times and the initial explant transformed into a mass of branches.

4. Stage 3. Rooting of shoots

Somatic embryos carry a pre-formed radical and may develop directly into plantlet. However, these embryos often show very poor conversion into plantlets, especially under *in vitro* conditions. They require an additional step of maturation to acquire the capability for normal germination. Adventitious and axillary shoots developed in cultures in the presence of a cytokinin generally lack roots. To obtain full plants the shoots must be transferred to a rooting medium which is different from the shoot multiplication medium, particularly in its hormonal and salt compositions. For rooting, individual shoots measuring 2 cm in length are excised and transferred to the rooting medium.

5. Stage 4. Transplantation

The ultimate success of commercial propagation depends on the ability to transfer plants out of culture on a large scale, at low cost and with high survival rates. The plants multiplied *in vitro* are exposed to a unique set of growth conditions (high levels of inorganic and organic nutrients, growth regulators, sucrose as carbon source, high humidity, low light, poor gaseous exchange) which may support rapid growth and multiplication but also induce structural and physiological abnormalities in the plants, rendering them unfit for survival under *in vivo* conditions. The two main deficiencies of *in vitro* grown plants are – poor control of water loss and heterotrophic mode of nutrition. Therefore, gradual acclimatization is necessary for these plants to survive transition from culture to the greenhouse or field. During acclimatization the *in*

in vitro formed leaves do not recover but the plant develops normal leaves and functional roots. While transferring out shoots/roots their lower part is gently washed to remove the medium sticking to them. The individual shoots or plantlets are then transferred to potting mix and irrigated with low concentration of inorganic nutrients. This probably recommissions the photosynthetic machinery of plants, enabling them to withstand the subsequent reduction in the ambient relative humidity and survive under field conditions. A variety of potting mixtures such as peat, perlite, polystyrene beads, vermiculate, fine bark, coarse sand etc. or their mixtures in different combinations are used for transplantation. For initial 10-15 days, it is essential to maintain high humidity (90-100%) around the plants, to which they got adapted during culture. The humidity is gradually reduced to ambient level over a period of 2-4 weeks.

In vitro* regenerative protocol of *V. reitzii

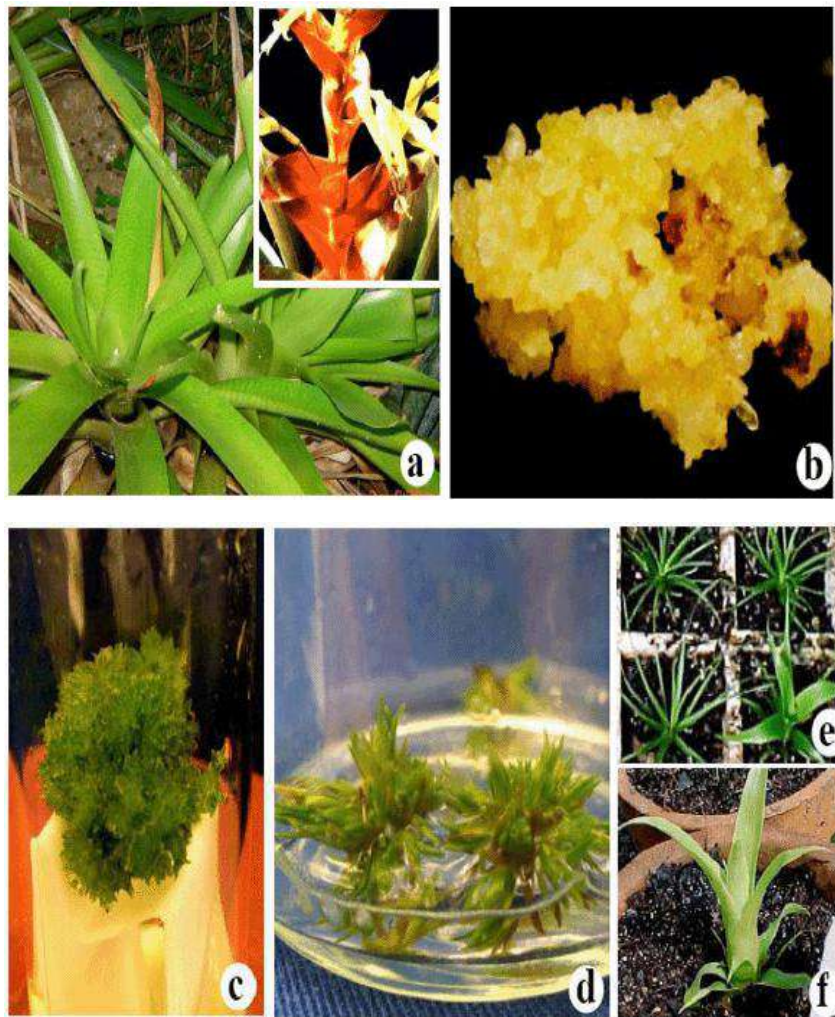
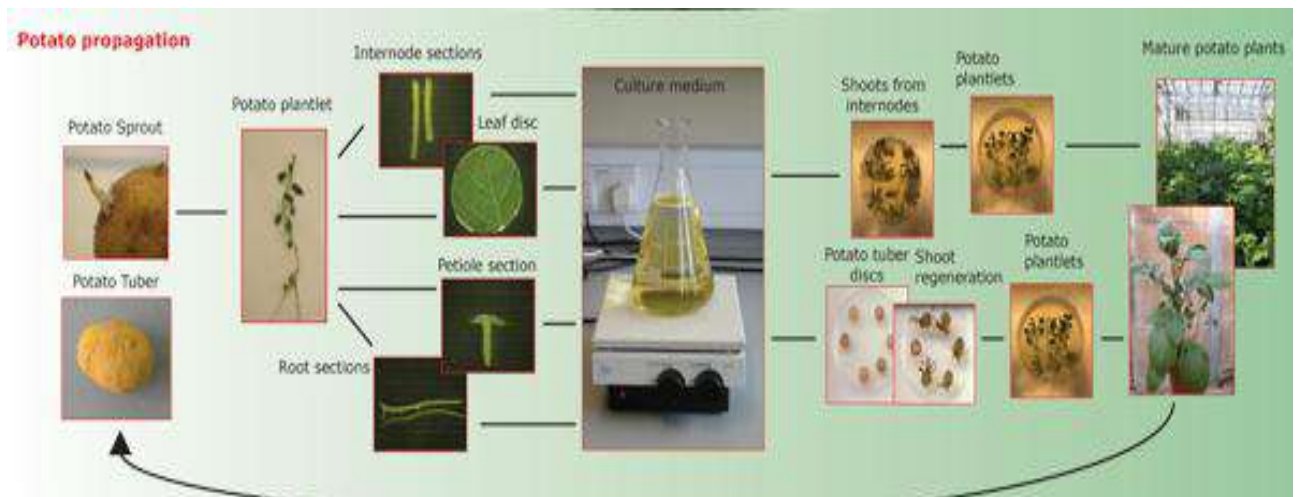
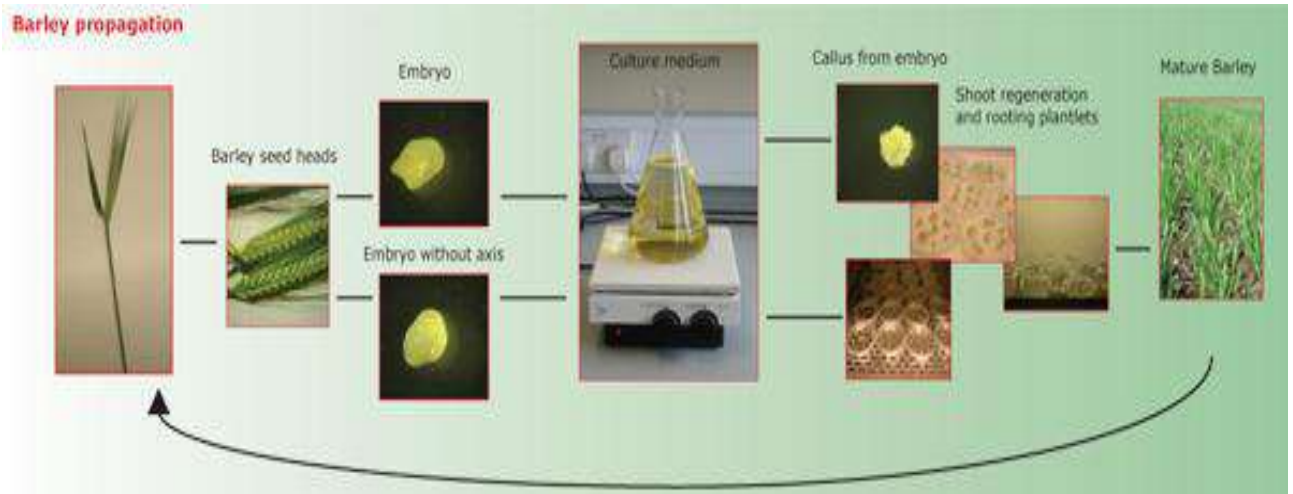

Figure 1 - Nodule cluster culture formation and shoot regeneration in *V. reitzii*. a) Donor plant, see in detail inflorescence of adult plant; b) Yellow nodular cluster cultures induced in MS medium free of PGR; c) Nodule cluster subcultured in MS culture medium supplemented with GA₃ (10 μ M) resulted in high proliferation rate and the subsequent development of adventitious microshoots; d) Elongation and growth of shoot in MS culture medium free of PGR; e) Acclimatization of plantlets; f) growth in greenhouse. CCA/UFSC, 2004



Advantages of micropropagation

1. Clonal mass propagation - extremely large numbers of plants can be produced. Rather than getting 10000 plants per year from an initial cutting in vegetative propagation, one can obtain more than 1,000,000 plants per year from one initial explant through micropropagation.
2. Culture is initialized from small parts of plants – so no need of much space: from 1 m² space in culture room, 20000 - 100000 plants can be produced per year.

3. Production of disease and virus free plantlets. This leads to simplification of international exchange of plants
4. Micropropagation enables growers to increase the production of plants that normally propagate very slowly such as *Narcissus* and other bulbous crops.
5. Introduction of disease free new cultivars is possible through micropropagation
6. Vegetative propagation of sterile hybrids can be used as parent plants for seed production. Eg. Cabbage
7. One of the rapid methods for cloning of disease free trees.
8. *In vitro* cultures can be stored for long time through cryopreservation.
9. Breeding cycle can be shortened.

Disadvantages of micropropagation

1. Expensive laboratory equipment and service
2. No possibility of using mechanization
3. Plants are not autotrophic
4. Poor Acclimatization to the field is a common problem (hyperhydricity)
5. Risk of genetic changes if 'de novo' regeneration is used
6. Mass propagation cannot be done with all crops to date. In cereals much less success is achieved
7. Regeneration is often not possible, especially with adult woody plant material.
8. More problems in inducing rooting
9. May not get uniform growth of original plant from tissue culture. Each explant has different *in vitro* growth rates and maturation. Thus cannot be used for floriculture crop production where uniformity is critical.

Horticultural uses for plant tissue culture

1. **Clonal mass propagation.** The important point here is that extremely large numbers of plants can be produced. Rather than getting 10000 plants per year from an initial cutting, one can obtain upwards of 1,000,000 plants per year from one initial explant.
2. **Difficult or slow to propagate plants.** Micropropagation enables growers to increase the production of plants that normally propagate very slowly such as narcissus and other bulbous crops.

3. **Introduction of new cultivars** eg. Dutch iris. Get 5 daughter bulbs annually. Takes 10 years for commercial quantities of new cultivars to be built up. Can get 100-1000 bulbs per stem section.

4. **Vegetative propagation of sterile hybrids** used as parent plants for seed production. Eg. cabbage.

5. **Pathology - Eliminate viruses, bacteria, fungi etc.** Use heat treatment and meristem culture. Used routinely for potatoes, carnation, mum, geranium, garlic, gypsophila

6. **Storage of germplasm**

Generally the only successful method to date is keeping them in refrigerator. Slows down, but does not eliminate, alterations in genotype.

Questions

1. Multiplication of genetically identical copies of a cultivar by asexual reproduction is called

- a) **Clonal propagation**
- b) Apomixis
- c) Vegetative propagation
- d) None of the above

2. In nature, clonal propagation occurs by

- a) Vegetative propagation
- b) Apomixis
- c) **Both a & b**
- d) None of the above

3. Apomixis is by

- a) **Seed development without meiosis and fertilization**
- b) Regeneration of new plants from vegetative parts
- c) Both a & b
- d) None of the above

4. Vegetative propagation is by

- a) Seed development without meiosis and fertilization
- b) **Regeneration of new plants from vegetative parts**
- c) Both a & b
- d) None of the above

5. Advantage of tissue culture is/are

- a) Production of large number of true-to-type plantlets from a single plant
- b) Less time requirement
- c) Less space requirement
- d) **All the above**

6. Total number of stages in micro propagation is

- a) 3
- b) 4
- c) **5**
- d) 6

7. stage involves the preparation of mother plants

- a) **Stage 0**
- b) Stage 1
- c) Stage 2
- d) Stage 3

8. stage involves the preparation of mother plants

a) **Stage 0**

c) Stage 2

b) Stage 1

d) Stage 3

9. Stage 0 in tissue culture is

a) **Preparative stage**

c) Multiplication

b) Initiation of culture

d) Rooting of shoots

10. Stage 1 in tissue culture is

a) Preparative stage

c) Multiplication

b) **Initiation of culture**

d) Rooting of shoots

11. Stage 2 in tissue culture is

a) Preparative stage

c) **Multiplication**

b) Initiation of culture

d) Rooting of shoots

12. Stage 3 in tissue culture is

a) Preparative stage

c) Multiplication

b) Initiation of culture

d) **Rooting of shoots**

13. Stage 3 in tissue culture is

a) Preparative stage

c) Multiplication

b) Initiation of culture

d) **Transplanting**

14. Stage 3 in tissue culture is

a) Preparative stage

c) Multiplication

b) Initiation of culture

d) **Transplanting**

15. The suitable explant for producing virus free plant is

a) **Shoot tip**

c) Stem bit

b) Leaf bit

d) None of the above

16. The oxidation of phenolic compounds leached out from the cut surface of the explant in tissue culture leads to

a) **Browning of the medium**

b) Blackening of the medium

- c) Whitening of the medium d) None of the above

17. The oxidation of phenolic compounds leached out from the cut surface of the explant in tissue culture leads to

- a) **Browning of the medium** b) Blackening of the medium
c) Whitening of the medium d) None of the above

18. Browning of medium is a common problem in

- a) **Adult tissues from woody species** b) Juvenile tissues from woody species
c) Both a and b d) None of the above

19. The crucial stage in tissue culture is

- a) Preparative stage b) Initiation of culture
c) **Multiplication** d) Rooting of shoots

20. In tissue culture, the multiplication is through

- a) Callusing b) Adventitious bud formation
c) Enhanced axillary branching d) **All the above**

Haploid production and uses

Haploids are defined as saprophytes with gametophytic chromosome number and have been produced in a variety of plant species using a variety of methods.

Although, the significance of haploids in genetics and plant breeding has been recognized for long time, with the advent of biotechnology it received renewed emphasis, so that the production of haploids become an important component of biotechnology programmes in different countries.

Although, haploids could be produced following delayed pollination, irradiation of pollen, temperature shocks, colchicine treatment and distant hybridization, the most important methods currently being utilized include

- Anther or pollen culture and ovule culture and
- Chromosome elimination following interspecific hybridization (bulbosum technique).

Anther and microspore culture

The impact of haploid production in genetics and plant breeding has long been realized. However, their exploitation remained restricted because of the extremely low frequency with which they occur in nature. Spontaneous production of haploids usually occurs through the process of parthenogenesis (embryo development from unfertilized egg). Rarely, they reproduce male parent alone. This suggest that their origin through 'ovule androgenesis' (embryo development inside the ovule by the activity of the male nucleus alone). In vivo occurrence of androgenic haploids has been reported in *Antirrhinum*, *Nicotiana* etc. the artificial production of haploids was attempted through distant hybridization, delayed pollination, application of irradiated pollen, hormone treatments and temperature shocks. However, none of these methods are dependable. The development of numerous pollen plantlets in anther culture of *Datura innoxia*, first reported by two Indian Scientists (Guha and Maheswari) was a major breakthrough in haploid breeding of higher plants. This technique of haploid production through anther culture (anther androgenesis or simply androgenesis) has been extended to numerous plant species including cereals, vegetables, oil and tree species.

The anthers may be taken from plants grown in the field or in pots, but ideally these plants should be grown under controlled temperature, light and humidity. Often the capacity for haploid production declines with age of donor plants. Flower buds of the appropriate developmental stage are collected, surface sterilized and their anthers are excised and placed horizontally on

culture medium. Care should be taken to avoid injury to anthers since it may induce callus formation from anther walls. Alternatively, pollen grains can be separated from anthers and cultured on a suitable medium.

Isolation of pollen

The pollen grains are released from the cultured anthers either mechanically. Or the cold treated anthers cultured on liquid medium burst open after 2-7 days liberating the pollen grains into the medium. This is called 'float culture method' which has proved better than mechanical isolation of pollen from fresh or pre-cultured anthers.

To improve the efficiency of isolated pollen culture for the production of haploids, Wenzel and his colleagues introduced the technique of density gradient centrifugation which allows the separation of embryogenic grains from a mixture of embryogenic and non-embryogenic grains obtained after crushing the anthers. The anthers of Barley obtained at the proper stage of development and gently macerated to obtain a suspension of pollen grains. After removing the debris by repeated filtration and centrifugation, the suspension was layered on 30% sucrose solution and centrifuged at 1200 g for 5 min. The androgenic, vacuolated pollen grains formed a band at the top of the sucrose solution. Isolated pollen culture is not only more efficient but also more convenient than anther culture. The tedious process of dissection of anthers is avoided. Instead, the entire buds within a suitable size range are crushed and the embryogenic grains are then separated by gradient centrifugation.

Pathways of development

The early divisions in responding pollen grains may occur in one of the following four ways.

1. Pathway I: The uninucleate pollen grain may divide symmetrically to yield two equal daughter cells both of which undergo further divisions. (*Datura innotura*)
2. Pathway II: In some other cases (*Nicotiana tabacum*, *Datura metel*, *Triticale*), the uninucleate pollen divides unequally (as it does in nature). The generative cell degenerates immediately or after undergoing one or two divisions. The callus/embryo originates due to successive divisions of the vegetative cells.
3. Pathway III: But in some species like *Hyoscyamus niger*, the pollen embryos originate from the generative cell alone; the vegetative cell either does not divide or divides only to a limited extent forming a suspensor like structure.

4. Pathway IV: In certain species such as *Datura innoxia* the uninucleate pollen grains divide unequally, producing generative and vegetative cells, but both these cells divide repeatedly to contribute to the developing embryo/callus.

Pollen grains of many crop species, e.g. Tobacco, Wheat, Barley etc., exhibit pollen dimorphism. Most of the pollen grains are bigger, stain deeply with acetocarmine and contain plenty of starch. But small portions of the pollen grains are smaller and stain faintly with acetocarmine; these are called S-grains. These S-grains only respond during anther culture. The frequency of responding pollen grains can be enhanced over that of S-grains by certain pretreatments, e.g. chilling. Pollen grains of the cultured anthers show remarkable cytological changes during the first 6-12 days, called the inductive period. In tobacco, the gametophytic cytoplasm of binucleate pollen grains is degraded, ribosomes are eliminated and only few mitochondria and plastids remain. New ribosomes are synthesized following the first sporophytic division of the vegetative cell.

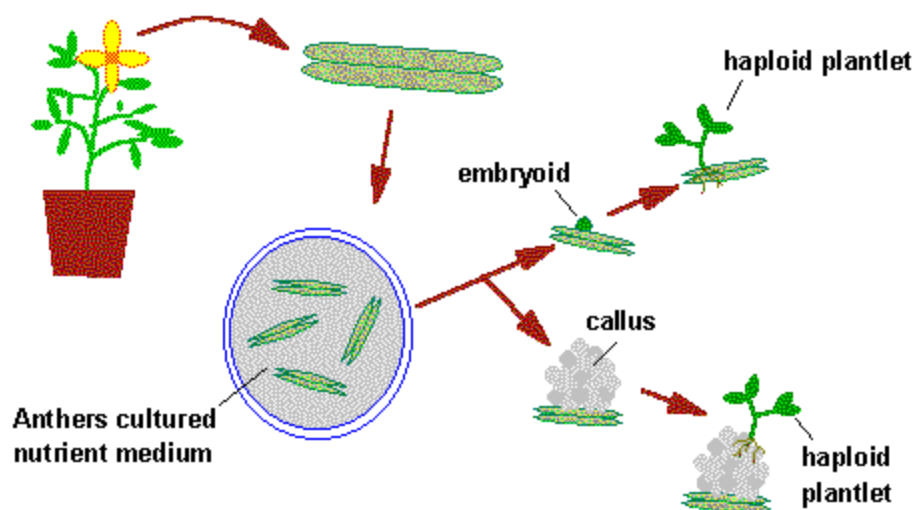

The responsive pollen grains become multicellular and ultimately burst open to release the cell mass. This cell mass may either assume the shape of a globular embryo and undergo the developmental stages of embryogeny or it may develop into callus depending on the species. Regeneration of plants from pollen callus or pollen embryos may occur on the original medium or it may require transfer to a different medium. The pollen embryo exhibit considerable similarity with zygotic embryos in their morphology and certain biochemical features. Often the pollen embryos do not germinate normally. Pollen embryos frequently produce secondary

embryos on stem surface and all such embryos which produce secondary embryos are haploid and the others non-haploid. To raise full plantlets from pollen embryos it is necessary to excise a cluster of the secondary embryos along with a part of the parent embryo and plant them on fresh medium. They do not germinate if left on the pollen embryo or removed individually.

Anther culture and haploid plants regeneration

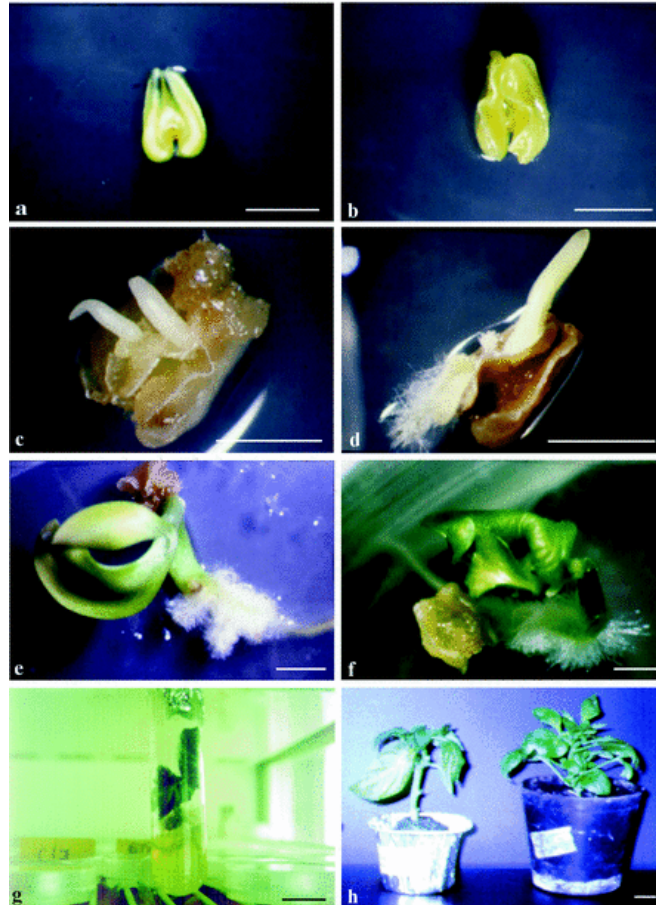

(a) Anther at the onset of the culture. (b) Anther after 6 days in culture. (c, d) Embryos emerging from the anthers after 30 days in culture, showing roots (c) and shoots (d). (e–g) Plantlets with cotyledons (e) and with leaves (f, g) subcultured in growing medium. (h) 80-day-old regenerated haploid plant from anther culture (left-hand side) and a diploid control of the same age (right-hand side). Scale bars in (a–d), 2.5 mm; in (e–h), 5 mm.

Factors affecting androgenesis

- Physiological status of the donor plants - The age of the donor plants and the environmental conditions under which it has been grown significantly affects the androgenic process. Generally, the buds from the first flush of flowers show better

response than those borne separately. Exposures of donor plants to nutrient and water stresses reported to promote androgenesis.

- Stage of pollen development- The pollen grains around the first mitosis is most responsive. The uninucleate microspores produce haploids while the binucleate pollen form plants of higher ploidy.
- Anther wall factors- the pollen from one cultivar of tobacco would successfully develop into an embryo even if transferred into the anthers of another cultivar.
- Genotype – hybrids are more androgenic than their parents.
- Pretreatment of cultured anthers/pollen grains – application of certain physical (temperature shock, centrifugation, γ irradiation) and chemical (auxins) treatments to cultured anthers or pollen grains prior to standard culture room conditions, has proved essential or promotory for in vitro androgenesis.
- Culture medium – addition of etherel (2-chloroethylphosphonic acid), sucrose, agar and other nutrients specific to certain genotype found to increase the success rate of androgenesis.
- Culture density- the frequency of pollen embryogenesis was enhanced if the anther culture density was increased from 3 anthers per ml to 12-24 anthers per ml in *Brassica oleracea*.
- Effect of gaseous environment- the composition of the gas mixture that surrounds the anthers has profound influence on the number of embryos produced in anther cultures. The removal of CO₂ from the culture vessel resulted in decline in anther culture response in *Nicotiana tobaccum*.
- Effect of light – Isolated pollen culture is more sensitive to light than anther culture.

Applications

- Production of diploids- homozygous lines of the cross pollinating species and hybrids are highly desirable to increase the efficiency of selection and production of homozygous plants. The conventional method to produce homozygous plants is lengthy and laborious, requiring 7-8 recurrent cycles of inbreeding. Moreover, this approach is impractical for self-incompatible and male sterile and tree species. On the other hand, homozygous plants can be obtained in a single generation by diploidization of the haploid. This kind of production of stable, homozygous dihaploids (DH) in a single generation equivalent to the F_{α} generation of pedigree breeding and thus considerably shortens the breeding cycle. Generally, colchicine is recommended to diploidize the pollen plants. In practice, the pollen derived plants are immersed in filter sterilized solution of colchicines or applied as lanolin paste or injecting into the secondary buds or by root feeding. Besides bringing about chromosome duplication, colchicines treatment may also result in chromosome and gene instabilities. Therefore, the frequent occurrence of spontaneous duplication of chromosomes in differentiated plant cells (cortex, pith) and callus cells in long term cultures has also been exploited to raise homozygous fertile diploids from haploid plants (Figure). In this method, pieces of vegetative parts such as stem, root or petiole segments are cultured in a suitable medium to induce callusing. The initial callus may have some diploid cells but their frequency would increase in repeated subcultures. Such calli are transferred to the plant regeneration medium. Many of the plants so derived are diploid. However, the ploidy of individual plants must be confirmed before incorporating them in further experiments.
- Normally, in a hybridization programme evaluation of lines is possible only after 4-5 years of backcrossing (F_5 or F_6 generations) and it takes another 4-5 years to release a new variety. By anther culture of F_1 hybrids the various genotypes of gametes can be fixed and evaluated in the first generation. Anther culture can itself generate new recombination and fix them simultaneously.
- Haploids are extremely useful for detecting recessive mutants which may not express themselves in the heterozygous diploid background and therefore can be easily lost.
- Gametoclonal variation –in vitro androgenesis provides a unique opportunity to screen the gametophytic variation caused by recombination and segregation during meiosis. For

example, a gametoclone of tomato, which bears fruits with higher solid content than the parent cultivar, has been produced through anther culture.

- Mutagenesis- Detection and isolation of recessive mutants in the haploid state and rapid obtainment of the mutated gene in a homozygous diploid state is a special merit of haploidy in higher plants. Application of mutagenic treatment at the microspore stage, which is a single celled structure, has the added advantage of obtaining solid mutants. Through, microspore mutagenesis, a mutant of *Brassica napus* with high oleic and low lanoleic acid content was obtained.
- Production of super male of *Asparagus officinalis*- In *A. officinalis*, a dioecious crop species, and an inbred population is produced through sib crosses between pistillate and staminate plants which yield 50 % males and 50 % females. However, the commercially desirable features of this crop are uniform male population with spears having low fiber content. Anther culture was used to produce haploids of this species and this was diploidized to raise homozygous males. These are called as super-males.

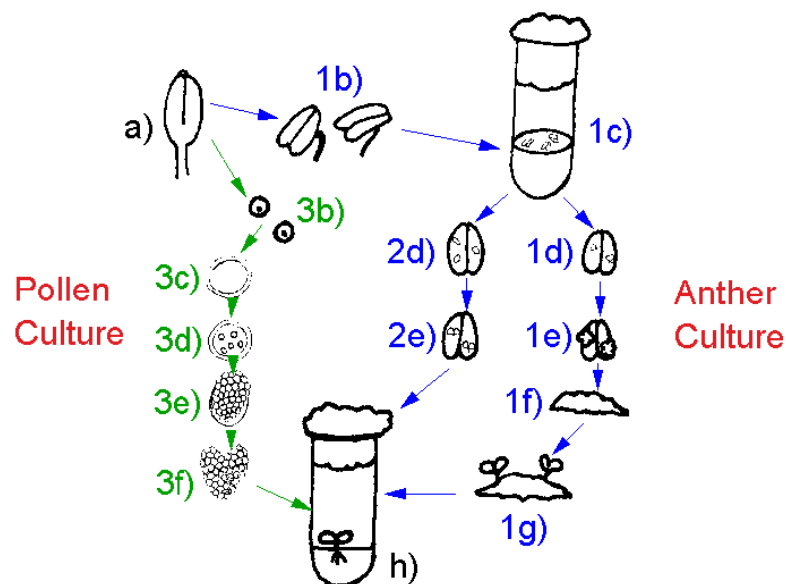

This diagram shows the various stages of anther and isolated pollen culture. The stages of anther culture from anther to haploid plantlet can be described as follows: a) an unopened flower bud, 1b) anthers, 1c) the anthers in culture, 1d) and 1e) proliferating anther, 1f) haploid

callus, 1g) differentiating callus, h) haploid plantlet. Isolated pollen culture is as follows: a) an unopened flower bud, 3b) isolated pollen from a cultured anther, 3c) pollen culture, 3d) multinucleate pollen, 3e) and 3f) pollen embryo.

Limitations

- Low Yield- generally 5-8% of the total pollen grains in a responding anther undergo androgenic development.
- 70-80% of the embryos are incapable of normal germination due to structural, physiological and biochemical abnormalities of pollen.
- Occurrence of high frequencies of albinos in cereals.
- Instability of genetic material during androgenesis.

Microspore culture

The ideal culture system for production of haploids is isolation and culture of microspores after separation from anther wall tissue.

Reasons

The influence of anther tissue can be detrimental.

Diploid tissue - Connective tissue is growing activity which is competitive with growth of haploid microspore which is soon submerged by profuse diploid callus. So, variable and numerous chromosomal alterations are noticed during culture.

Methods

Spontaneous

A combination of pretreatment and incubation is given. - Anthers will dehisce in liquid medium and produce callus/embryo which will float from somatic tissue. eg. Brassica, cereals, solanaceae.

Homogenisation and filtration

Pretreated anthers are cultured for 3-4 days gently crushed with a glass rod/syringe piston in liquid medium to allow the microspores squeezed out. The suspension with anthers and microspores are filtered through a nylon sieve which allows microspore to pass through. The filtrate is centrifuged for 5 minutes at 100g. After discarding the supernatant, wash pollen at

least once and re suspend in liquid medium at initial density in petridish and incubate.(e.g. Solanaceae, rape, sugarcane

Slit technique

Cutting the anther wall to release the microspore calluses/embryos rather than relying on natural dehiscence but this is a time consuming process (e.g.) tobacco.

Uses of haploids

- Production of homozygous varieties in self pollinated crops.
- In cross-pollinated crops, the derivation from heterozygous material of pure lines for use as parents of the intended single cross or double cross hybrids.
- The obvious advantage of haploids is that they display mutations with successive effects in single dose.
- Effective fixation by chromosome doubling on transformation.
- Double haploid plants are also used in mutagenesis, biochemical, and physiological studies.
- Development of pure lines and disease resistant lines for mildew and yellow mosaic- barley
- Parthenogenetic haploids in maize
- Recovery of sexual inter specific hybrids between wild and domestic species - tomato
- Development of pure lines and 100% male plants in asparagus
- Complex hybrids for disease resistance in coffee

Questions

1. The most important methods currently utilized for haploid production include

- a) Anther or pollen culture
- b) Ovule culture
- c) Bulbosum technique
- d) All the above**

2. Bulbosum technique is

- a) Chromosome elimination
- b) Chromosome elimination following interspecific hybridization**
- c) Chromosome elimination following intraspecific hybridization
- d) None of the above

3.

Bulbosum technique is used for

- a) Haploid production**
- b) Triploid production
- c) Tetraploid production
- d) None of the above

4. The development of numerous pollen plantlets in anther culture of *Datura innoxia* was first reported by

- a) Guha
- b) Maheswari
- c) Both a & b**
- d) None of the above

5. The process of parthenogenesis is

- a) Embryo development from fertilized egg
- a) Embryo development from unfertilized egg**
- c) Embryo development
- d) None of the above

6. The capacity for haploid production

- a) Declines with age of donor plants**
- b) Increases with age of donor plants
- c) Unaffected with age of donor plants
- d) None of the above

7. In pollen culture, isolation of pollen grains from the cultured anthers is by

- a) Mechanical method
- b) Float culture method
- c) Both a & b**
- d) None of the above

8. Pollen dimorphism is exhibited by

- a) Tobacco
- b) Wheat

- c) Barley **d) All the above**

9. In vitro androgenesis is promoted by pretreatment of cultured anthers/pollen grains viz.

.....

- a) Temperature shock b) Centrifugation
c) γ irradiation **d) All the above**

10. Addition of..... found to increase the success rate of androgenesis.

- a) Ethrel b) Sucrose
c) Nutrients specific to certain genotype **d) All the above**

Ovule culture

Culturing of immature ovules is resorted to in cases, where pollination is successful but for certain reason of incompatibility, the seeds do not develop beyond a certain stage. The procedure can succeed only if at least a few days have elapsed after fertilization.

Depending upon, when the embryo aborts, the ovules have to be excised any time from soon after fertilization to almost developed fruits, which may sometimes be lost due to premature abscission.

For a variety of difficult interspecific/intergeneric crosses involving members of the families Malvaceae, Fabaceae, Cruciferae, Solanaceae, etc., ovules after fertilization have been successfully cultured to obtain mature embryos/seeds.

However, ovule culture is mainly tried only in those cases, where embryo aborts very early, and embryo culture is not possible due to difficulty of its excision at a very early stage. In some cases, the medium may need to be supplemented with some fruit/vegetable juice to accelerate initial growth.

Ovule culture in orchids

Nimoto and Sagawa (1961) were the first to attempt this in orchids. According to them the seeds could be taken out for culturing only about 55 days after pollination. But Israel (1963) reports having taken seeds out of the ovaries seven days after pollination and cultured them to seedling stage.

There are some genera like *Cypripedium* and *Paphiopedilum* whose seeds are especially difficult to germinate. In such cases the seeds coat is said to contain certain substances which retard or even prevent the process of germination (Northern, 1970). Culturing of ovules before seed coat is developed fully will give a higher percentage of germination in such cases. The immature pod is sterilised, cut open with a sterile knife and the seeds scooped out and put in a vial containing distilled water. It is shaken well and the seeds sown to come in direct contact with the seeds. Other special techniques have also been suggested to tackle such hard to germinate seeds. Kano (1968) reported that immersing of seeds in sterilised water for 5 hours prior to flasking and sealing the flasks entirely quickened the process of germination of the seeds.

of *Cymbidium virescens* and *C. gyrokuchin*. Similarly soaking of seeds of *Cypripedium acaule* (Which is very difficult to germinate under normal conditions) in a sterile nutrient solution for 15-45 days and putting them in unaerated flasks, is reported to hasten germination. Flasks should preferably be kept at 25°C and under diffuse light, in an incubator or in a green house under glass.

The process of ovule culture can be divided into two parts: first is the preparation of the medium where the ovule will be cultured and the second is the actual culture of the ovule.

The components of the culture medium include inorganic nutrients that are essential for the plant to complete its life cycle, such as sugar, vitamins, amino acid, organic supplement such coconut water, growth regulators, agar as a gelling agent, and other supplements that are deemed necessary. In the case of orchids, the Knudson medium is being utilized as it is specially formulated for orchids.

The actual culture proceeds after the preparation of the medium. To achieve an aseptic condition, the inoculation chamber is disinfected by spraying 80 percent ethyl alcohol on the surface where the whole process will be performed.

An orchid pod which contains the seeds of the orchid is secured and rubbed with 95 percent ethyl alcohol for preliminary sterilization. Inside the chamber, the whole pod will be dipped in a bottle 1/3 full of 95 percent ethyl alcohol for 3 to 5 seconds with the aid of a scalpel and forceps. The pod, after being dipped in an ethyl alcohol, will be flamed at least thrice until the alcohol on the surface has evaporated. Such series of steps are performed to ensure that the surface of the pod is free from contaminants.

After the surface sterilization, the pod is sectioned on a sterile petri dish with the aid of sterile forceps. Once the pod has been opened, thousands of orchid ovule will be revealed. The ovules will be carefully scraped off from the pod with the use of scalpel and will be carefully dropped into the bottle of the culture medium. Once the ovules have settled inside, the bottle will be covered tightly with cotton plugs and will be placed in a cool and well-lighted place. .

Signs of successful germination in the culture of orchid are when the orchid seeds start to swell and turn green. Sooner, the embryo becomes bigger and assumes the shape of a top. At this point, the structure is no longer an embryo, but a protocorm. At this stage, the protocorms are

ready for reflasking. The protocorms will be transferred from one culture bottle to another with the use of a spatula. Reflasking is necessary since this will provide room for further growth and development for the protocorms. Four to eight months after reflasking, the protocorms will become bigger and ready to be planted out of the culture bottle for potting.

Just like any process, this technique requires skills in performing the media preparation and culture, and knowledge, especially on stages of development of embryo.

Questions

1. Ovule culture is practiced in the members of the families like
a). Malvaceae b). Fabaceae c). Cruciferae **d). All the above**

2. Ovule culture is mainly tried in case(s).
a). embryo aborts very early b). embryo culture is not possible due to difficulty of its excision at a very early stage
c). **Both a & b** d). None of the above

3. Ovule culture is first attempted in
a). Orchidaceae b). Fabaceae c). Malvaceae d). Cruciferae

4. Ovule culture is first attempted by
a). Northern **b). Nimoto and Sagawa** c). Kano d). None of the above

Ovary and embryo culture

Culture of unfertilized ovaries to obtain haploid plants from egg cell or other haploid cells of the embryo sac is called ovary culture and this process is termed as gynogenesis. San Noem first reported the gynogenesis in barley in 1976. Subsequently, success has been obtained in several species including wheat, rice, maize, tobacco, sugar beet, rubber etc. About 0.2-6% of the cultured ovaries show gynogenesis and one or two, rarely up to 8, plantlets originate from each ovary. The rate of success varies considerably with:

- ✓ Species
- ✓ Markedly influenced by the genotype so that some cultivars do not respond at all. e.g. In rice, *japonica* genotypes are far more responsive than *indica* genotypes.
- ✓ Stage of ovary development. In most cases, the optimum stage for ovary culture is the nearly mature embryo sac, but in rice ovaries at free nuclear embryo sac stage are the most responsive. Generally, culture of whole flowers, ovary and ovules attached to placenta respond better, but in *Gerbera* and Sunflower isolated ovules show better response. Cold pretreatment (24-48 hr at 4°C in sunflower and 24 hr at 7°C in rice) of the inflorescence before ovary culture enhances gynogenesis.
- ✓ Growth regulators:

Growth regulators are crucial in gynogenesis and at higher levels they may induce callusing of somatic tissues and even suppress gynogenesis. Growth regulator requirement seems to depend on species. For example, in sunflower, GR-free medium is the best, while even at low level MCPA (2-methyl-4-chlorophenoxyacetic acid) induces somatic calli and SEs. But in rice, 0.125-0.5 mg/l MCPA is optimum for gynogenesis.
- ✓ Other Factors:

Sucrose level also appears to be critical. In sunflower, 12% sucrose leads to gynogenic embryo production, while at lower levels somatic calli and somatic embryos were also produced. Ovaries/ ovules are generally cultured in light, but atleast in some species, e.g., sunflower and rice, dark incubation favours gynogenesis and minimises somatic callusing. In rice, light may lead to degeneration of gynogenic proembryos.

Developmental stages

Generally, gynogenesis has two or many stages and each stage has distinct requirements. In rice, tow stages viz., induction and regeneration are recognized. During

induction, ovaries are floated on a liquid medium having low auxin and kept in dark, while for regeneration they are transferred on to an agar medium with higher auxin concentration and incubated in light.

Haploid plants generally originate from egg cell in most of the species (in vitro parthenogenesis) but in some species, e.g., rice, they arise chiefly from synergids; in atleast *Allium tuberosum* even antipodals produce haploid plants (in vitro apogamy). As in anther culture, gynogenesis may occur either via embryogenesis or through plantlet regeneration from callus. In rice MCPA generally leads to a small amount of protocorm like callus formation from which shoots and roots regenerate, while picloram promotes embryo regeneration. In contrast, sugarbeet usually shows embryo development, while in sunflower embryos regenerate following a callus phase. In general, regeneration from a callus phase appears, at least for the present, to be easier than direct embryogenesis.

Advantages

1. Gynogenetic haploids may be a valuable substitute for the production of homozygous lines in cases where cytoplasmic male sterility prevents the use of microspores.
2. Reduction in the frequency of albino plants in some species especially cereals.

Limitations

1. So far it has been successful only in less than two dozens species.
2. The frequency of responding ovaries (1-5%) and the number of plantlets/ovary (1-2) is quite low.
3. Therefore, anther culture is preferred over ovary culture. Only in those cases where anther culture fails, e.g. sugarbeet and for male sterile lines, ovary culture assumes significance.

Embryo culture

In angiosperms the embryo is the miniature sporophyte resulting from the fertilized egg or zygote. In seed bearing plants, embryos are easily accessible as they can be separated with relative ease from the maternal tissues and cultures *in vitro* under aseptic conditions in media of known chemical composition. The culture of embryo has been practiced by plant breeders for over half a century.

The first systematic attempt to grow the embryos of angiosperms *in vitro*, under aseptic conditions was made by Hanning (1904) who cultured mature embryos of *Raphanus* and the conifers *Cochlearia*. Subsequently, many workers raised plants by cutting embryos excised from mature seeds. Further progress in the field of embryo culture was provided by Liabach (1925, 1929) who demonstrated the most important practical application of this technique. He crossed *Linum perenne* with *Linum austriacum* but obtained hybrid seeds of very light and shriveled nature without any germinability. The excised embryos from such seeds were cultured on moist filter paper dipped in sucrose solution. This led to the production of hybrid plants. Since then, the technique of embryo culture has been widely used to produce hybrids which were otherwise not possible due to embryo abortion. Further, embryo culture method offers new refined ways to characterise the development of embryo and related problems in plants.

The selection of plant to be used for embryo culture is normally dictated by the problem in hand. When the goal is to obtain plants from otherwise abortive seeds, the embryos should be excised for culture prior to the onset of abortion. Zygotic embryos, being enclosed within the sterile environment of the ovular and ovarian tissues, do not require surface sterilization. Entire ovules are disinfected following the standard methods of surface sterilization and embryos are dissected out and transferred to culture medium under aseptic conditions.

For the *in vitro* culture of embryo generally, it is necessary to excise them from their surrounding tissues. The mature embryos can be isolated with relative ease by splitting open the seeds. Seeds with a hard seed coat are dissected after soaking them in water. For plants with minute seeds, the isolation of embryos can be done under dissecting microscope on a sterilized slide. In plants like, orchids, where the seeds are minute and lack functional endosperm the entire ovules having embryos are cultured on the medium.

Types

- Culture of immature embryos originating from unripe seeds that is mainly to avoid embryo abortion with the purpose to produce a viable plant.
- Culture of mature embryos derived from ripe seeds.

Factors affecting the success of embryo culture

Before attempting to elucidate the application of embryo culture method, it is necessary to analyze briefly the factors influencing the embryo culture technique.

- ✓ Genotypes
- ✓ Developmental stage of the embryo at isolation. The culture of very young embryos is very difficult. Despite considerable progress in the field of embryo culture, embryo rescuing seems to be difficult where embryo abortion occurs at a very early stage of development. To culture very young embryos successfully, the embryo of a particular species is implanted in the endosperm from another seed of the same species. For example, in the cross of *Hordeum x Secale* the survival rate with the implantation technique was 30-40 per cent as compared to one per cent with traditional method of embryo culture. This technique is termed as embryo-nurse endosperm transplant technique.
- ✓ Growth conditions of the mother plant
- ✓ Composition of the nutrient media

The most important aspect of the embryo culture is the selection of the right culture medium that would support progressive and orderly development of embryos excised at different stages of development. The requirement of culture medium depends on the types of embryo culture. They may be either post-germinal or pre-germinal. In the case of post-germinal embryo culture, embryos are cultured only to speed up the process after germination. This can be achieved with less complex medium or even with sucrose or glucose solution. In pre-germinal embryo culture, immature embryos are cultured to get plantlets, where the embryos require a complex nutrient medium. Refinement of nutrient medium for the culture of embryos includes modifications in the composition of mineral salts, organic nutrients and growth regulators, as for any other type of plant tissue cultures.

The composition of the culture medium has to be formulated in such a way to suit the developmental phase of the embryo. There are two phases in embryo development (1) heterotrophic phase in which the embryo draws its nutrients from the endosperm and the surrounding maternal tissues and (2) autotrophic phase in which the embryo is metabolically capable of synthesizing substances required for growth.

Addition of amino acids and vitamins, promoted the development of the embryo. Casein hydrolysate, an amino acid complex has been widely used as an additive to the embryo culture media. The natural plant extracts like coconut milk, tomato juice and extracts of banana produce higher recovery of growth and development of embryos.

Growth hormones, especially auxins are not used in embryo culture media because of their inhibitory role in embryo growth resulting in structural abnormalities.

✓ **Suspensor and embryo culture**

The suspensor is transitory structure found at the radicle end of the proembryo. It promotes the growth of the young embryos and degenerate in the later stages of embryo growth, i.e., after the formation of cotyledons. Mostly embryos cultured without the suspension showed lesser survival and maximum necrosis thus reducing the frequency of plantlet formation.

- ✓ Light
- ✓ Temperature

Practical applications

Embryo rescue in wide crosses

In plants the embryo inviability occurs due to many causes, though there is normal fertilization and development in the early stage. The impairments start subsequently, resulting in the eventual death of embryo or from the endosperm or from the surrounding maternal tissue.

To overcome the above barriers for obtaining the hybrids, the embryo culture technique is effectively utilized in which the nutritional relationship between the embryo and endosperm is restored by providing the artificial medium to induce and complete growth of hybrid embryos and is called as embryo rescuing. The demonstration of the ability of the excised embryos from non-viable seeds to grow successfully in artificial medium supplied with nutrients bypassed the problems of wide hybridization and to enable transference of resistant genes for pests and diseases and various environmental stresses into the cultivated species.

The embryo culture technique is not only adopted to produce interspecific hybrids, but also extended to produce viable hybrids between genera. Intergeneric hybrids have been obtained between *Hordeum* and *Secale*; *Hordeum* and *Hordelymus*, *Triticum* and *Elymus*; *Triticum* and *Secale* and *Tripsacum* and *Zea*.

However, for the successful embryo rescuing in interspecific and intergeneric crosses, the composition of the artificial nutrient medium is very important. The reason is that the medium formulated to foster growth of embryos of one hybrid combination may not

be suitable for another. To overcome the constraints in the artificial medium in inducing the growth of embryos, the following technique is followed in which the hybrid embryos embedded in hybrid endosperm are removed and transplanted or implanted into the normal endosperm. This technique is termed as embryo implantation. This technique was first proposed by Pissarev and Vinogradova in 1944. The embryo implantation technique could be an alternative to improve the crossability between two species. Kruse (1974) proposed a similar method to rescue hybrid embryos from *Hordeum x Triticale*, *Hordeum x Agropyron* and *Hordeum x Secale* crosses. The hybrid embryo is removed from a dehulled caryopsis and placed in the correct position in the endosperm of *Hordeum* placed in a culture medium.

Monoploid production

The advantages of haploids as tools in genetics or plant breeding become more apparent because of their following utility values

- they provide the quickest possible way to get homozygosity
- they may serve to recover recessives
- the gametes of monoploids remain as best source for linkage studies
- the doubled products of monoploids from crosses provide stable recombinants
- the monoploids are useful in genome homology studies
- the monoploids are ideal objects for mutation studies
- the monoploids are useful in gene transfer studies

Considering the above mentioned advantages, monoploid induction and regeneration is considered as a powerful tool in plant breeding. The details of monoploid production from microspores have been described in the chapter on Anther Culture. Here how the embryo culture technique could be exploited for monoploid production is discussed. The technique, popularly known as Bulbosum technique is exploited for producing the monoploids and is based on making an interspecific cross with *Hordeum vulgare* as the female and *H. bulbosum* as male. In this cross fertilization of *H. vulgare* by *H. bulbosum* proceeds normally. During zygote development, the chromosomes of *H. bulbosum* are eliminated from the cells of the developing embryo. The endosperm starts developing and then degenerates. At this stage, the embryonic cells harbour only the set of *H. vulgare* genome and show poor rate of division resulting in smaller haploid embryos. These smaller haploid embryos with little endosperm are dissected out and cultured *in vitro* to produce the haploids. Following *in vitro* embryo culture, the developing haploid plantlets of *Hordeum vulgare* are reared and raised under normal green house conditions and chromosome

doubling is induced on established plants. This method has the advantage of throwing very high frequencies of monoploid (haploid) induction.

Overcoming seed dormancy

The other major application of embryo culture in breeding is as a means of overcoming seed dormancy. Seeds of certain species germinate very slowly or not at all under normal conditions. The cause may be in the form of endogenous inhibitors, lesser length, high temperature, storage condition and maturity of the embryo. These problems can overcome by providing specific signals for seed germination, rightly through embryo culture. Examples include *Iris*, *Ilex*, *Viburnum*, *Paeonia*, *Brassica chinensis*, *Musa bulbisiana*, etc.

Shortening breeding cycle of plants

Embryo culture is also useful in reducing the breeding cycle of new varieties in cases where long dormancy causes extension of breeding cycle. Cultivated varieties of rose generally take about a year to flower and two to three months for the formation of fruits. Seedlings produced from cultured embryos flower in two to three months. These flowers can serve as the male parent for further crosses, thus enabling the breeder to produce two generations in one year or shortening the breeding cycle to three or four months. Other example is weeping crab apple (*Malusop*) in which the seeds cultured *in vitro* produce seedling in four months. On the other hand, seeds planted in the soil take about nine months to germinate.

Combining embryo culture and back crossing in gene transfer

The embryo culture has been proved as a viable technique for resynthesising some of the plant hybrids. For example *Brassica napus* has been resynthesised from the cross of *B. campestris*/*B. oleracea* using embryo culture. The recent approach is back crossing the resynthesised *B. napus* ($2n=38$) to *B. campestris* ($2n=20$), so that the genes from *B. oleracea* can be transferred to *B. campestris*. In 1988 **Quazi** made an attempt in this regard and came out with successful results. He got a line from the back crosses of (*B. napus*/*B. oleracea*)/*B. oleracea* which is resistant to cabbage aphid attack. Following the same approach **Milanova** and his co-workers (1991) produced cytoplasmically male sterile tobacco plants from *Nicotiana africana* and *N. tabaccum* cross. Thus the scheme facilitates gene transfer overcoming the species barrier.

Other applications

The embryo culture technique can be effectively engaged in seed testing of various tree species, germinating seeds of obligate phanerogamic parasites, studying the host-pathogen relationship in seed-borne diseases and studying developmental embryogenesis. The embryo culture technique has already established its creditability as an invaluable tool in plant breeding and advances in embryo culture method have served to open new vistas in the field of *in vitro* culture. But greater attention has to be paid to solve the minute intricacies which remain as big hurdles in the exploitation of embryo culture.

Embryo rescue

Distant crosses may fail due to one or more of several reasons such as inability of pollen to germinate, failure of pollen tubes to grow or perhaps more commonly degeneration of endosperm. When embryo fails to develop due to endosperm degeneration, embryo culture is used to recover hybrid plants. This is called as hybrid rescue through embryo culture. Some recent examples are the recovery of hybrids from *Hordium vulgare* X *Secale cereale*, *Triticum aestivum* X *Agropyron repens*, *H. vulgare* X *Triticum aestivum* etc., In case of *Triticale* rare combinations between *Triticale* and *Secale* develop viable seeds. But most of the tetraploid and hexaploid wheat carry two dominant genes, *Kr1* and *Kr2*, which prevent seed development in crosses with *Secale*. The majority of the hybrid seeds is small, poorly developed and show very poor germination. Further, seeds are obtained from only 5-10% of the florets pollinated. The recovery of hybrid seedlings is much greater (50-70%) when embryos from 10-14 day old caryopses are removed and cultured on a suitable medium.

Bulbosum technique

Principle

The fertilization proceeds readily between *H. vulgare* and *H. bulbosum*. Zygote induction is high and chromosomes of *H. bulbosum* are rapidly eliminated from the cells of developing embryo. This develops for two to five days and then aborts. In the developing monoploid embryo cells, the division and increment is slower than the diploid cells. This comparatively slow growth of the monoploid condition, together with the disintegration of the endosperm leads to the formation of small embryos which have to be dissected out of the fruits and provided with nutrients *in vitro* in order to complete their development. Following *in vitro* embryo culture, the developing plantlets are raised under normal green house conditions and chromosome doubling is induced on established plants.

Advantages

- The method of hybridization followed by chromosome elimination proves to be of general interest for haploid production in other species of *Hordeum* and also of hexaploid wheat.
- It is possible to produce monploids of barley in a cytoplasm of *H. bulbosum* by using *H. vulgare* as male and *H. bulbosum* as female. Using embryo culture as vehicle, high frequency foreign cytoplasm monploids can be obtained.
- *Hordeum* species is not the only one where chromosome elimination is found in higher plants. In Haplopoppus, monploids have been examined with only two chromosomes. *H. bulbosum* need not be the ideal partner for *H. vulgare* to induce monploids of barley via somatic chromosome elimination. There can be a range of *Hordeum* that might be tried as a more efficient pattern than *H. bulbosum*.

Questions

1. Embryo culture is used
 - a) To overcome embryo abortion
 - b) To overcome seed dormancy
 - c) Embryo rescue in distant hybridization
 - d) All the above**

2. Ovary culture is first reported by
 - a). Northern
 - b). San Noem**
 - c). Kano
 - d). None of the above

3. Ovary culture is first reported in
 - a). Barley**
 - b). Sorghum
 - c). Cotton
 - d). None of the above

4. Embryo culture is first reported in
 - a). Raphanus**
 - b). Sorghum
 - c). Cotton
 - d). None of the above

5. Embryo culture is first reported by
 - a). Hanning**
 - b). San Noem
 - c). Kano
 - d). None of the above

6. The success of embryo culture depends on
 - a). Developmental stage of the embryo at isolation
 - b). Growth conditions of the mother plant
 - c). Composition of the nutrient medium
 - d). All the above**

7. The growth hormone not used in embryo culture medium is
 - a). Auxin**
 - b). Gibberellin
 - c). Cytokinin
 - d). None of the above

8. The embryo imlantation technique was proposed by
 - a). Pissarev
 - b). Vinogradova
 - c). Both a & b**
 - d). Kruse

9. The embryo culture is used for
 - a). Embryo rescue
 - b). Monoploid production
 - c). To overcome seed dormancy
 - d). All the above**

10. Bulbosum technique is used for
 - a). Embryo rescue**
 - b). Monoploid production
 - c). To overcome seed dormancy
 - d). All the above

Additional readings...

<http://www.youtube.com/watch?v=m5JEZq0Fxuk&feature=related> - video

Test tube fertilization

The task of the plant breeder can be made difficult by any of the following eventualities: the pollen fails to germinate on the stigma, the growth of the pollen tube in the style partially or completely stagnates, no fertilization takes place, the fertilized egg cell does not develop *in vivo* and aborts, or abscission of the ovaries occurs permanently. If no fertilization takes place after self pollination or cross pollination then it is referred to as self incompatibility or cross incompatibility. In some cases the plant breeder must resort to special procedures to bring about fertilization e.g. by ovule fertilization (here the pollen is artificially brought into contact with the ovules).

It was not until 1962 that did the idea arose of bringing about fertilization *in vitro* when this was not possible *in vivo*. Despite the fact that little research had been carried out in this area a few interesting examples of test tube fertilization were found.

In vitro fertilization is of particular importance if the incompatibility is present on the stigma or in the style.

In vitro fertilization can take place in three different ways:

1. **Stigma fertilization:** in this method an emasculated flower is extremely sterilized and then isolated *in vitro*. Pollen from a ripe anther (which has been externally sterilized) is then placed on the stigma. This method, which is similar to fertilization *in vivo*, can be used, if for example, the ovaries fall off the plant prematurely, resulting in lack of progeny. Using stigma fertilization success has been achieved with: *Nicotiana rustica*, *N. tabacum*, *Petunia violacea*, *Antirrhinum majus*, *Pisum sativum*, *Lathyrus odoratus*, *Zea mays* and *Glycine* species.
2. **Placental fertilization:** An intact flower is externally sterilized and placenta explants with unfertilized ovules are dissected under a stereomicroscope and inoculated onto a nutrient medium. At the same time anthers which are still closed and at a stage where they would be just about to open *in vivo* are externally sterilized. The anthers are opened under sterile conditions and the pollen grains placed near the ovules. After this, time is required to determine whether the pollen grains germinate, if they penetrate the embryo sac and whether fertilization follows. Placental fertilization is practiced with members of the *Caryophyllaceae*, *Gossypium* and *Zea mays*.

3. **Fertilization of an isolated ovule without a placenta:** This method is same as in 2 from the time that the ovule is isolated *in vitro*. There has been little success with this method since it is extremely difficult to induce embryo formation in *in vitro* fertilized ovules.

In vitro fertilization can be used in the following cases:

1. Placental pollination is sometimes possible when the plants are completely self incompatible *in vivo*. E.g. *Petunia axilaris*, *Petunia hybrids*.
2. Cross fertilization may be possible *in vitro* even if it is impossible *in vivo*. Hybrid plants after test tube fertilization of ovules of *Nicotiana alata* with pollen from *Nicotiana tabacum*. Intergeneric crosses can also be achieved *in vitro*, as seen with different members of the *Caryophyllaceae*; for this family it has been shown that the pollen grains germinate better with placental fertilization *in vitro* than on the stigma *in vivo*.
3. Production of haploids by parthenogenesis.
4. The abscission of a flower or ovary is sometimes unavoidable. In such a case stigma fertilization may be effective.
5. To study the physiology of the fertilization.

In general little is known about the conditions necessary for fertilization *in vitro*. However, it seems certain that:

1. The pollen grains and the ovules must be in the correct physiological and morphological state.
2. The choice of nutrient medium is extremely important. It is not surprising that this choice is very difficult processes have to take place one after the other: germination of the pollen grains, fertilization and growth of the embryo into a seed. A complex mixture of compounds is often used to induce growth of the embryo.
3. When sterilizing flowers for use with the stigma fertilization, care should be taken that the stigma is not in contact with the sterilizing agent for too long or the exudates on the stigma will be dissolved.

4. With stigma fertilization it is better not to remove the sepals from the flower, since they encourage the growth of the ovary.
5. Stigma fertilization may still be possible despite failure of placental fertilization.
6. Temperature may be a decisive factor.

Questions

1. In vitro fertilization can take place through

- a) Stigma fertilization
- b) Placental fertilization
- c) Fertilization of an isolated ovule without a placenta
- d) All the above**

2. Stigma fertilization is successful in

- a) *Nicotiana rustica*
- b) *Zea mays*
- c) *Pisum sativum*
- d) All the above**

3. Placental fertilization is successful in

- a) *Caryophyllaceae*
- b) *Zea mays*
- c) *Gossypium*
- d) All the above**

4. The conditions necessary for in vitro fertilization include

- a) Physiological state of pollen and ovule
- b) Morphological state of pollen and ovule
- c) Nutrient medium
- d) All the above**

Endosperm culture

In angiosperms the endosperm is the main nutritive tissue for the embryo. The endosperm is the product of **double fertilization** during which out of the two male gametes, one fertilizes the egg to form zygote and other fuses with secondary nuclei to form triploid endosperm. Hence, triploid nature of endosperm is the characteristic feature of angiosperms. Both mature and immature endosperm can be used for culture initiation. A key factor for the induction of cell divisions in mature endosperm cultures is the initial association of embryo but immature endosperms proliferate independent of embryo. The endosperm tissue often shows a high degree of chromosomal variations and polyploidy. Mitotic irregularities, chromosome bridges and laggards are the other important characteristics of endosperm tissues. Triploids are usually seed sterile and is undesirable for plants where seeds are commercially useful. However, in cases where seedlessness is employed to improve the quality of fruits as in banana, apple, citrus, grapes, papaya etc. the induction of triploid plants would be of immense use. Triploid plants have more vigorous vegetative growth than their diploid counterparts. Hence, in plants where the vegetative parts are economically useful, triploids are of good use.

The endosperm is a homogenous mass of parenchymatous tissue lacking in vascular elements. Since the endosperm tissue lacks in differentiation into specialised tissue and vascular element their utility in the study of experimental morphogenesis is well appreciated. Attempts to grow endosperm under *in vitro* condition dates back to 1930 by the scientist Lampe and Mills. The young corn endosperm was cultured on the extract of potato or young corn by the above scientist and slight proliferation of tissue was noticed from the tissues surrounding the embryo. In 1947, LaRue, successfully cultured the corn endosperm and obtained plantlets with root-shoot axis and miniature leaves. Several investigators, since then, have cultured the endosperm tissue but invariably have failed to induce organogenesis. However, successfully organogenesis was achieved from endosperm callus tissue of *Ricinus communis*, *Oryza sativa* and *Pyrus malus*.

Corn endosperm



Callus induction from endosperm

During the early period of endosperm culture, there was difficulty in establishing callus induction from mature endosperm. Of late successfully regeneration of triploid plantlets are being achieved. The process of regeneration may be direct from the endosperm or *via* callus stage.

Callus tissue is induced from the endosperm explant in usual manner as with other explant. The endosperm tissue is homogenous in nature surrounded by a single peripheral layer of meristematic cells. These meristematic cells undergo repeated periclinal and anticlinal divisions resulting in increased girth of endosperm tissues and in turn producing callus with nodular structures on the surfaces or just below the outer most layer. The plants, which have so far responded favourably, belong to the families of *Euphorbiaceae*, *Loranthaceae* and *Santalaceae*. With respect to members of first two families the embryo has to be maintained intact along with endosperm in culture, to induce the callus from the endosperm. In these cases, immediately after the callus induction from the endosperm the embryo should be removed under aseptic conditions to avoid the formation of embryo-endosperms callus mixtures. The essentially of the initial association of the embryo endosperm for inducing proliferation is that during germination of the embryo, it releases gibberellin - like substances which turn in help in *de novo* synthesis of other enzymes responsible for the endosperm proliferation. These substances are otherwise called 'embryo factors'.

The age of endosperm is critical factor influencing proliferation of endosperm tissue. Endosperm cultured immediately after pollination normally do not proliferate. In crops like rice, maize, endosperm proliferates 7 to 8 days respectively after pollination. In many cases, endosperm of cellular nature proliferates more easily than nuclear endosperm or coenocytic endosperm. In some species the culture of endosperm with their embryo produced favourable condition for the proliferation of endosperm whereas in species like *Taxillus verstitus*, culture of endosperm after cutting it into two species produced better results. In endosperm culture, the proliferation thus induced occurs at different duration and it is a genotype dependent phenomenon. For example, the endosperm of *Ricinus communis* proliferated 10 days after culture whereas the endosperm of *Pyrus malus* and *Santalum* took 15 to 21 days respectively for proliferation.

Morphogenesis of endosperm callus

Straus (1954) stated that the endosperm tissue has passed through approximately 95 transfers and has produced an estimated 15 kilograms of tissue. Not a single example of

complex differentiation was observed during the period. However, both organogenesis and somatic embryogenesis were observed, in other cases. The first convincing evidence of organ formation was from *Exocarpus cupriformis*. The incidence of organogenesis from the above species was noticed in the form of shoot buds all over the surface of the endosperm. Apart from the direct organogenesis in the form of buds, the organogenesis may also follow the pathway *via* the callus stage. The formation of shoot buds increased with increase in cytokinin concentration and decrease in auxin concentration. In general, endosperms of all the plant species showed increased bud formation with response to higher concentration of cytokinin. The studies on the role of auxin (IAA) and cytokinin (kinetin) revealed that cytokinin alone was more effective in combination with auxin: there was no differentiation in the absence of cytokinin, but cytokinin is not always necessary to induce bud formation from normal tissue. But for endosperm tissues to produce buds cytokinin is required. Presence of organic additives like tomato juice, coconut milk, casein hydrolysate, yeast extract in the culture medium enhanced endosperm proliferation and regeneration.

Application of endosperm culture

The cultured endosperm forms an excellent experimental system for physiological and morphogenetic studies. This system shows great promise in the study of metabolism and differentiation. The triploidy can be exploited in the crops *viz.* apple, banana, mulberry, sugarbeet, tea and watermelon where seeds are not of commercial importance. In some plants especially in clonally propagated ones triploids are superior to the diploids giving better pulp woods. Since these plants can be propagated vegetatively seed sterility is not a severe setback. In the case of conventional method of triploid production, crosses are made between auto tetraploids and diploids. Sometimes, these crosses may not be successful causing difficulty in triploid production.

Nature of impairments in embryo development and causes

Causes	Source	Example
Normal initial rate of growth followed by retardation in later stage	Embryo	<i>Oenothera biennis</i> x <i>O. muricata</i> <i>O. biennis</i> x <i>O. lamarkiana</i>
Paucity of cell organelles due to lower synthetic capacity of hybrid genome, necrosis and dumping	Embryo	<i>Hibiscus costatus</i> x <i>H. aculeatus</i> <i>H. costatus</i> x <i>H. furcellatus</i>
Hybrid failure due to pollen incompatibility	Pollen incompatibility	<i>Pinus pence</i> x <i>P. cembra</i> <i>P. strobus</i> x <i>P. flexilis</i>
Disintegration of endosperm soon after fertilization	Endosperm	<i>Oenothera</i> and <i>Gossypium</i>
Vacuolation in endosperm cells at chalazal and not followed by further cell division	Endosperm	<i>Lycopersicon pimpinellifolium</i> x <i>L. peruvianum</i>
Abnormal behaviour of antipodals and preventing nutrient supply to embryos	Endosperm	<i>Citrus (2x)</i> / <i>Citrus (4x)</i> <i>Gossypium hirsutum</i> x <i>G. arboreum</i>
Intrusive growth of somatic tissue causing somatoplastic sterility	Nucellus	<i>Nicotiana rustica</i> x <i>N. tabacum</i> <i>N. rustica</i> x <i>N. glutinosa</i>
Non-differentiation of integumentary cells into connective tissues to connect main vascular bundle with chalazal tissue	Integuments	<i>Nicotiana</i> hybrids

Examples of wide crosses

Wide crosses	Purpose
<i>Corchorus capsularis</i> x <i>C. olitorius</i>	Hybrids had fibres with quality of <i>C. capsularis</i> and strength of <i>C. olitorius</i>
<i>Hordeum vulgare</i> x <i>H. bulbosum</i>	The hybrids possessed winter hardiness and mildew resistance like <i>H. bulbosum</i>
<i>Lycopersicon esculentum</i> x <i>L. peruvianum</i>	The hybrids possessed resistance to viruses, molds and nematodes along with good fruit set like <i>L. peruvianum</i>
<i>Melilotus officinalis</i> x <i>M. alba</i>	Hybrids resembling <i>M. officinalis</i> in agronomic characters and low coumarin content like <i>M. alba</i>
<i>Nicotiana tabacum</i> x <i>N. glauca</i>	To get plants with resistance to black shank
<i>Oryza sativa</i> x <i>O. officinalis</i>	To transfer pest resistance
<i>Trifolium pratense</i> x <i>T. sarosense</i>	To impart perennial plant habit to red clover

Questions

1. Endosperm is in nature
a). **Triploid** b). Tetraploid c). Monoploid d). Diploid
2. Endosperm is product of fertilization
a). **Double** b). Single c). Triple d). None of the above
3. Triploid nature of endosperm is the characteristic feature of
a). **Angiosperms** b). Gymnosperm c). Pine d). None of the above
4. The important characteristics of endosperm tissues are
a). Chromosomal variations b). Polyploidy
c). Chromosome bridges and laggards **d). All the above**
5. Successful organogenesis was achieved from endosperm callus tissue of
a). *Ricinus communis* b). *Oryza sativa*
c). *Pyrus malus* **d). All the above**
6. Endosperm culture is successful in
a). *Euphorbiaceae* b). *Santalaceae*
c). *Loranthaceae* **d). All the above**
7. Triploidy is exploited in
a). Apple b). Banana
c). Watermelon **d). All the above**

Additional sources

<http://www.youtube.com/watch?v=Gq8NWh98wQs&feature=related> - video

<http://www.tutorvista.com/content/biology/biology-iii/angiosperm-morphology/fertilization.php>

Factors influencing morphogenesis

Morphogenesis in culture proceeds along a number of pathways. Of them, two are major pathways - organogenesis and somatic embryogenesis. Organogenesis includes direct genesis of adventitious shoots or roots and indirectly *via* callusing. Embryogenesis also possesses two pathways where the outcome differs in the form "bipolar somatic embryos" which in later stage form individual plantlets. Several factors influence the phenomenon of morphogenesis considerably during culture. They are: genotypes, explant, growth regulators, nutrients, other additives and physical environment.

Genotype

In the plant kingdom, certain plant groups appeared to respond more readily in culture than others. Members of carrot family (*Umbelliferae*) are considered to be a group that can readily form somatic embryos in culture. However, differences in response were observed among the different species of a genus and different cultivars in a species. It is now well accepted that genetic factors contribute to the response of plant tissues in culture. Though there are reports of recalcitrance among plant species to culture, this problem can be successfully overcome by manipulation of explants, culture medium or culture environment.

Explant

Although all cells in a plant are considered totipotent, there are striking differences from cell to cell and from organ to organ within a plant to regenerate plants. In general, embryonic, meristematic and reproductive tissues appear to have greater potential for growth and morphogenesis in culture. For woody species, it is possible to regenerate some types of organs only when embryos or young inflorescences are cultured. The inoculum must comprise actively dividing cells or juvenile cells. It is a well known fact that physiological stage of the mother plant, its nutritional and environmental conditions would also affect the explant for morphogenesis. So the mother plant should be grown in a well controlled environment to get reproducible results even though some changes in endogenous rhythm are not avoidable.

Growth regulators

It is known that the control of morphogenesis in the majority of the cultures is largely a function of the exogenous auxin/cytokinin ratio. High concentrations of kinetin cause

shoot initiation, whereas high levels of auxin favour rooting. In somatic embryogenesis, auxin is required for induction of embryonic cells and maintenance of proliferative growth. Embryo formation can be induced by transferring the callus to less auxin medium or a medium lacking auxin. Plant growth regulators other than auxins and cytokinins have been shown to play an important role in the induction and control of morphogenesis. Gibberellic acid has been used most successfully to obtain rapid growth of shoot apices and somatic embryos into plants.

Nutrient medium

Components of nutrient medium play critical roles in controlling morphogenesis in culture. Effects of many inorganic and organic nutrients have been studied extensively. One of the most important components of the medium in effecting morphogenesis is the source and concentration of nitrogen. Supply of high levels of reduced nitrogen appears suitable to shoot formation and essential to somatic embryogenesis. This is supplied in the form of ammonium nitrate and sometimes substituted with amino acids such as glutamine, glycine and alanine and their amides. Presence of potassium in the medium enhances embryogenesis.

Other additives

Supplementation of medium with casein hydrolysate and coconut milk also favour the morphogenesis *in vitro*. Coconut milk has been employed extensively as a medium component for somatic embryogenesis.

Culture environment

Temperature, photoperiod, light intensity and osmotic concentration are other factors that may have determining role in organogenesis and embryogenesis. The optimum temperature for culture is $24 \pm 2^{\circ}\text{C}$. Low temperature treatment of explants prior to culture favours their regenerative ability. Light also exerts a strong morphogenetic effect on plants in culture. Usually cultures produce shoots but the period of lighting should be maintained according to the photoperiodism of normal environment. The blue region of the spectrum promotes shoot formation and red light favours rooting. In the light, the somatic embryos of carrot formed plants; in the absence of light etiolation occurred. Overall osmotic concentration of a medium can also exert a profound effect on

morphogenesis. Increased osmotic levels in medium enhance shoot and somatic embryo formation. The osmotic level can be increased by adding additional sucrose.

Loss of morphogenetic ability

Cultures *in vitro* capable of morphogenetic potential initially lose the ability if they are subcultured repeatedly. Such subcultures may bring the changes at genetic, epigenetic and physiological levels. Variation in ploidy level of cells cultured is the usual change occurring at genetical level. Such variations may be either polyploidy or aneuploidy. Sometimes gene mutations also occur in the cultured cells.

The epigenetic level changes occurring in culture are partially stable but reversible. Habituation to a partial particular component may produce morphogenetic loss in *in vitro* culture. For example, the embryogenic cultures grown in auxin plus medium would produce somatic embryos when the cultures are transferred to auxin free medium. The continuous culturing of callus or suspensions would lose the morphogenetic potential. This may be due to higher concentration of endogenous auxin. But these cultures can be made to produce embryos by depleting endogenous auxin level. For this the medium should have activated charcoal which has the potential to absorb certain amount of auxin.

Reduced growth rate less friability and senescence of cultures are the changes that occur at physiological level. These changes are temporary and unstable. By providing optimum chemical and physical environment, such morphogenetic losses can be overcome. Thus there are many reasons for the loss of morphogenetic ability by cultures, but there are indications of number of techniques that will help to reduce, if not eliminate, the problem.

Culture vessel to soil

The cellular totipotency is exploited in basic and applied aspects of plant science. This potential is not blocked with mere demonstration of organogenesis or somatic embryogenesis, but effectively utilized in propagating and producing entire plantlets, similar to mother plant and new genotypes respectively. The success of this technique depends on the method followed to establish plantlets in the soil, which have been cultured in an entirely new environment. The method requires details on rate of

multiplication of a particular explant and the rate of establishment of regenerated plantlets in soil. Adequate knowledge on manipulation of media, explant and culture environment to maintain the rate of multiplication at maximum is available. Having obtained a large number of regenerated plantlets, it is customary and necessary to transfer them to natural conditions. This is a critical period since the plantlets removed from the controlled environment of test tube or flask is going to face the real world. Under *in vitro* conditions, the plantlets have a carefully controlled supply of nutrient, humidity, temperature and photoperiod. The high humidity prevailing under culture conditions induces rapid shoot growth and proliferation. During this time, cuticle coverings of leaves and root hairs are poorly developed. If such plants are transferred to natural conditions, there would be substantial loss of water and desiccation due to cuticular and stomatal transpiration. So care must be taken during transfer of plantlets from *in vitro* condition to natural condition. Important points to be considered during transfer of plantlets to soil are:-

- Plantlets should be allowed to develop a good root system. The cultures with shoots may be transferred to a medium containing a weaker auxin for the better rooting.
- If the plantlets have been grown on agar-solidified medium, the agar may be removed by gentle washing with warm water.
- Damage to the root system should be avoided.
- After washing, the plantlets may be kept under higher intensity of light than the intensity of culture room for five to six days.
- The plantlets are then carefully planted in small plastic cups and the young roots surrounded with fine sand. It is better to sterilize the peat soil mixture in an autoclave to eliminate microbial pathogens.
- The small potted plantlets should be transferred to a controlled environment chamber, where control of light, temperature and humidity are possible.
- Then plantlets may be kept in mist chamber for increasing periods of light and temperature. During this hardening period, the plants will develop normal cuticular system with good rooting.

The above mentioned steps make regenerants to grow under natural conditions is collectively called as **hardening** and this process enhances the plant survival after transplanting.

Applications and achievements

Tissue culture consists of growing plants cells as relatively on organized masses of cells on an agar medium (callus culture) or as a suspension of free cells and small cell masses in a liquid medium (suspension culture). Tissue culture is used for vegetative multiplication of many species and in some cases for recovery of virus-free plants. It has potential application in production of somatic hybrids, organelle and cytoplasm transfer, genetic transformation and germplasm storage through freeze-preservation. Having the right plant material the right media and the right working environment crop improvement through tissue culture becomes less difficult. Crops which have gone the process of tissue culture have several advantages.

The various applications of plant tissue and cells culture techniques are as below:

Micropropagation /clonal propagation

Clonal propagation refers to the process of asexual reproduction by multiplication of genetically identical copies of individual plants. The vegetative propagation of plants is labour-intensive, low in productivity and seasonal. The tissue culture methods of plant propagation, known as 'micropropagation' utilizes the culture of apical shoots, axillary buds and meristems on suitable nutrient medium. The regeneration of plantlets in cultured tissue was described by Murashige in 1974. Fossard (1987) gave a detailed account of stages of micropropagation.

The micropropagation is rapid and has been adopted for commercialization of important plants such as banana, apple, pears, strawberry, cardamom, many ornamentals (e.g. Orchids) and other plants. The micropropagation techniques are preferred over the conventional asexual propagation methods because of the following reasons:

- In the micropropagation method, only a small amount of tissue is required to regenerate millions of clonal plants in a year.
- Micropropagation is also used as a method to develop resistance in many species.
- *In vitro* stock can be quickly proliferated as it is season independent.
- Long term storage of valuable germplasm possible.

The factors that affect micropropagation are:

- Genotype and the physiological status of the plant e.g. plants with vigorous germination are more suitable for micropropagation.

- The culture medium and the culture environment like light, temperature etc. For example an illumination of 16 hours a day and 8 hours night is satisfactory for shoot proliferation and a temperature of 25⁰C is optimal for the growth.

The benefits of micropropagation are:

- Rapid multiplication of superior clones can be carried out throughout the year, irrespective of seasonal variations.
- Multiplication of disease free plants e.g. virus free plants of sweet potato (*Ipomea batatus*), cassava (*Manihot esculenta*)
- Multiplication of sexually derived sterile hybrids.
- It is a cost effective process as it requires minimum growing space.

Production of virus free plants

The viral diseases in plants transfer easily and lower the quality and yield of the plants. It is very difficult to treat and cure the virus infected plants therefore the plant breeders are always interested in developing and growing virus free plants.

In some crops like ornamental plants, it has become possible to produce virus free plants through tissue culture at the commercial level. This is done by regenerating plants from cultured tissues derived from

- Virus free plants,
- Meristems that are generally free of infection

In the elimination of the virus, the size of the meristem used in cultures play a very critical role because most of the viruses exist by establishing a gradient in plant tissues. The regeneration of virus-free plants through cultures is inversely proportional to the size of the meristem used.

- Meristems treated with heat shock (34-36⁰C) to inactivate the virus
- Callus, which is usually virus free like meristems.
- Chemical treatment of the media- attempts have been made to eradicate the viruses from infected plants by treating the culture medium with chemicals e.g. addition of cytokinins suppressed the multiplication of certain viruses.

Among the culture techniques, meristem-tip culture is the most reliable method for virus and other pathogen elimination. Viruses have been eliminated from a number of economically

important plant species, which has resulted in a significant increase in the yield and production e.g. potato virus X from potato, mosaic virus from cassava etc.

Rejuvenation plant materials

Plant tissues from an old plant can be rejuvenated through tissue culture and able to grow again as new. e.g. old cassava material have been rejuvenated to produce young plantlets through tissue culture.

Somaclonal variation

Plants regenerated from tissue and cell cultures show heritable variation for both qualitative and quantitative traits; such a variation is known as somaclonal variation. Somaclonal variation has been described in sugarcane, potato, tomato etc. Some variants are obtained in homozygous condition in the plants regenerated from the cells *in vitro* (R_0 generation), but most variants are recovered in the selfed progeny of the tissue culture-regenerated plants (R_1 generation). Somaclonal variation most likely arises as a result of chromosome structural changes, e.g., small deletions and duplications, gene mutations, plasma gene mutations, mitotic crossing over and possibly, transposons. Somaclonal variation may be profitably utilized in crop improvement since it reduces the time required for releasing the new variety by at least two years as compared to mutation breeding and by three years in comparison to back cross method of gene transfer. A majority of the variants obtained and described so far is considered as boon to the crop improvement and some of the systems are explained below.

1. **Sugarcane:** Through tissue culture, variants with resistance to eye spot disease (*Helminthosporium sacchari*) Fiji disease (Virus) and downy mildew (*Sclerospora sacchari*) were isolated. The variants showed higher resistance to Fiji disease and downy mildew than their parent clones. Even resistant lines exhibited a shift towards higher resistance.
2. **Potato:** The protoplast culture in the potato cultivar Russet Burbank, an important cultivar excluded from potato improvement because of its sterility, produced total of 1,700 somaclones. From this huge population, 15 stable somaclones were identified, thus providing enough variability for potato improvement. In the same way, somaclone having resistance to late blight (*Phytophthora infestans*) and early blight (*Alternaria solani*) were identified.

3. **Maize:** In maize, the plants with T cytoplasm are male sterile and *Drechslera maydis* T. toxin susceptible. When these plants were subject to *in vitro* culture, somaclones were produced with the characters of male fertility and toxin resistance. The result was due to alterations in mtDNA which is responsible for toxin tolerance.

4. **Rice:** Somaclones were observed in the dihaploids of cultivar Norin 10 for chlorophyll development, plant height, heading date, maturity and grain yield. In the same way, doubled haploid regenerants from the cultivar Calrose 76 showed variation for height, seed number and size, panicle size and leaf morphology, tiller number and height.

5. **Wheat:** The embryo culture technique adopted in wheat has thrown out some 200 plants from a single immature embryo. The initial somaclonal regenerants displayed phenotypic variations. The analysis of regenerants obtained from the cultivar Yaqui 50E showed variations for the characters like plant height, maturity, tiller number, presence of awns, glume colour, grain colour, etc. The existence of somaclonal variation was also supported by the appearance and disappearance of some specific bands of gliadin protein.

Somaclonal variation in agronomically important plant species

Species	Explant	Variant characters	Transmission
<i>Avena sativa</i>	Immature embryo, apical meristem	Plant height, heading date, leaf striping, awns	Sexual
<i>Triticum aestivum</i>	Immature embryo	Plant height, spike shape, awns, maturity, tillering, leaf wax, gliadine, amylase	Sexual
<i>Oryza sativa</i>	Seed embryo	Number of tillers, panicle size, seed fertility, flowering date, plant height	Sexual
<i>Saccharum officinarum</i>	Various	Eyespot, Fiji virus, downy mildew, culm colour, spot disease, auricle length, esterase isozyme, sugar yield	Asexual
<i>Zea mays</i>	Immature embryo	Endosperm and seedling mutants, <i>D. maydis</i> race T toxin resistance mtDNA sequence rearrangement	Sexual
<i>Solanum tuberosum</i>	Protoplast, leaf callus	Tuber shape, yield, maturity date, plant habit, stem, leaf and flower morphology, early and late blight resistance	Asexual
<i>Lycopersicon esculentum</i>	Leaf	Male sterility, jointless pedicel, fruit colour, indeterminate type	Sexual
<i>Nicotiana species</i>	Anthers, protoplasts, leaf callus	Plant height, leaf size, yield grade index, alkaloids, reducing sugars, specific leaf chlorophyll loci	Sexual

<i>Medicago sativa</i>	Immature ovaries	Multifoliate leaves, petiole length, plant habit, plant height, dry matter yield	Asexual
<i>Brassica species</i>	Anthers, embryos, meristems	Flowering time, growth habit, waxiness, glucosinolates, <i>Phoma lingam</i> tolerance	Sexual

Applications of somaclonal variations

- Methodology of introducing somaclonal variations is simpler and easier as compared to recombinant DNA technology.
- Development and production of plants with disease resistance e.g. rice, wheat, apple, tomato etc.
- Development of biochemical mutants with abiotic stress resistance e.g. aluminium tolerance in carrot, salt tolerance in tobacco and maize.
- Development of somaclonal variants with herbicide resistance e.g. tobacco resistant to sulfonylurea.
- Development of seeds with improved quality e.g. a new variety of *Lathyrus sativa* seeds (*Lathyrus Bio L 212*) with low content of neurotoxin.
- Central Institute for Medicinal and Aromatic Plants (CIMAP), Lucknow, India has released bio-13 – a somaclonal variant of *Citronella java* (with 37% more oil and 39% more citronellon), a medicinal plant as Bio-13 for commercial cultivation.
- Super tomatoes- Heinz Co. and DNA plant Technology Laboratories (USA) developed Super tomatoes with high solid component by screening somaclones that helped in reducing the shipping and processing costs.

Mutant selection

An important use of cell cultures is in mutant selection in relation to crop improvement. Biochemical mutants are far more easily isolated from cell cultures than from whole plant populations. This is because a large number of cells, 10^6 - 10^9 , can be easily and effectively screened for biochemical mutant cells. The frequency of mutations can be increased several fold through mutagenic treatments and millions of cells can be screened. A large number of reports are available where mutants have been selected at cellular level. The cells are often selected directly by adding the toxic substance against which resistance is sought in the mutant cells. Using this method, cell lines resistant to amino acid analogues, antibiotics, herbicides, fungal toxins etc have actually been isolated. Biochemical mutants could be selected for disease resistance, improvement of nutritional quality, adaptation of plants to

stress conditions, e.g. saline soils, and to increase the biosynthesis of plant products used for medicinal or industrial purposes.

Amino acid analogue resistant mutants

Cereal grains are deficient in lysine; maize (*Zea mays*) is also deficient in tryptophan, while wheat (*T.aestivum*) and rice (*O.sativa*) are deficient in threonine. Pulses are deficient in methionine and tryptophan. Amino acid analogue-resistant cells may be expected to show a relatively higher concentration of that particular amino acid. For e.g., carrot (*D.carota*) and tobacco (*N.tabacum*) cell lines resistant to tryptophan analogue 5-methyl tryptophan show a 10-27-fold increase in the level of tryptophan. Similarly, rice cells resistant to lysine analogue 5-(*B-aminoethyl*)-cysteine, show much higher levels of lysine. This technique may prove useful in the development of crop varieties with better-balanced amino acid content.

Disease resistant mutants

Many pathogenic bacteria produce toxins that are toxic to plant cells. Plant cell cultures may be exposed to lethal concentrations of these toxins and resistant clones isolated. Plants regenerated from these resistant clones would be resistant to the disease producing pathogen. This technique should be applicable to all the pathogens, which produce the disease through the action of toxin. The technique can be applied to those cases only where the disease is the result of a toxin produced by the pathogen. But many of the pathogens do not seem to produce a toxin, or the toxin does not appear to be the primary cause of the disease.

Stress resistant and other mutants

Plant cells resistant to 4-5 times the normally toxic salt (NaCl) concentration have been isolated. Attempts to isolate such cells are being made. Similarly, attempts are being made to isolate clones that would produce more substances of medicinal or industrial value.

Production of somatic hybrids and cybrids

The Somatic cell hybridization/ parasexual hybridization or Protoplast fusion offers an alternative method for obtaining distant hybrids with desirable traits significantly between species or genera, which cannot be made to cross by conventional method of sexual hybridization. The applications of somatic hybridization are as follow:

a) **Creation of hybrids with disease resistance** - Many disease resistance genes (e.g. tobacco mosaic virus, potato virus X, club rot disease) could be successfully transferred

from one species to another. E.g resistance has been introduced in tomato against diseases such as TMV, spotted wilt virus and insect pests.

b) **Environmental tolerance** - using somatic hybridization the genes conferring tolerance for cold, frost and salt were introduced in e.g. in tomato.

c) **Cytoplasmic male sterility** - using cybridization method, it was possible to transfer cytoplasmic male sterility.

d) **Quality characters** - somatic hybrids with selective characteristics have been developed e.g. the production of high nicotine content.

Somatic hybridization

Protoplasts can be isolated from almost every plant species and cultured to produce callus. Protoplasts of two different species may be fused with the help of polyethylene glycol.

Gene transformation

Important crops can be greatly improved by genetic engineering by isolating a specific gene and then transferring it to selected crops. This raises the possibility of genetic modification of plant cells with the help of both homologous (from the same species) and heterologous (from a different species) DNA. It is also proposed that DNA plant viruses, such as cauliflower (*B.oleracea*) mosaic virus and potato leaf roll virus, plasmids (e.g., *Ti plasmid of Agrobacterium*) and transposons, may be used as the carriers of genes for genetic modification of plant cells.

***In vitro* plant germplasm conservation**

Germplasm refers to the sum total of all the genes present in a crop and its related species. The conservation of germplasm involves the preservation of the genetic diversity of a particular plant or genetic stock for its use at any time in future. It is important to conserve the endangered plants or else some of the valuable genetic traits present in the existing and primitive plants will be lost. The germplasm is preserved by the following two ways:

(a) **In-situ conservation**- The germplasm is conserved in natural environment by establishing biosphere reserves such as national parks, sanctuaries. This is used in the preservation of land plants in a near natural habitat along with several wild types.

(b) **Ex-situ conservation**- This method is used for the preservation of germplasm obtained from cultivated and wild plant materials. The genetic material in the form of seeds or *in vitro* cultures are preserved and stored as gene banks for long-term use.

In vivo gene banks have been made to preserve the genetic resources by conventional methods e.g. seeds, vegetative propagules, etc. ***In vitro*** gene banks have been made to

preserve the genetic resources by non - conventional methods such as cell and tissue culture methods. This will ensure the availability of valuable germplasm to breeder to develop new and improved varieties.

The methods involved in the *in vitro* conservation of germplasm are:

(a) Cryopreservation- In cryopreservation (Greek-krayos-frost), the cells are preserved in the frozen state. The germplasm is stored at a very low temperature using solid carbon dioxide (at -79°C), using low temperature deep freezers (at -80°C), using vapour nitrogen (at -150°C) and liquid nitrogen (at -196°C). The cells stay in completely inactive state and thus can be conserved for long periods. Any tissue from a plant can be used for cryopreservation e.g. meristems, embryos, endosperms, ovules, seeds, cultured plant cells, protoplasts, calluses. Certain compounds like- DMSO (dimethyl sulfoxide), glycerol, ethylene, propylene, sucrose, mannose, glucose, praline, acetamide etc are added during the cryopreservation. These are called cryoprotectants and prevent the damage caused to cells (by freezing or thawing) by reducing the freezing point and super cooling point of water.

(b) Cold storage- Cold storage is a slow growth germplasm conservation method and conserves the germplasm at a low and non-freezing temperature ($1-9^{\circ}\text{C}$). The growth of the plant material is slowed down in cold storage in contrast to complete stoppage in cryopreservation and thus prevents cryogenic injuries. Long-term cold storage is simple, cost effective and yields germplasm with good survival rate. Virus free strawberry plants could be preserved at 10°C for about 6 years. Several grape plants have been stored for over 15 years by using a cold storage at temperature around 9°C and transferring them in the fresh medium every year.

(c) Low pressure and low oxygen storage- In low- pressure storage, the atmospheric pressure surrounding the plant material is reduced and in the low oxygen storage, the oxygen concentration is reduced. The lowered partial pressure reduces the *in vitro* growth of plants. In the low-oxygen storage, the oxygen concentration is reduced and the partial pressure of oxygen below 50 mmHg reduces plant tissue growth. Due to the reduced availability of O_2 , and reduced production of CO_2 , the photosynthetic activity is reduced which inhibits the plant tissue growth and dimension. This method has also helped in increasing the shelf life of many fruits, vegetables and flowers.

The germplasm conservation through the conventional methods has several limitations such as short-lived seeds, seed dormancy, seed-borne diseases, and high inputs of cost and labour. The techniques of cryo-preservation (freezing cells and tissues at -196°C) and using cold storages help us to overcome these problems.

Production of synthetic seeds

In synthetic seeds, the somatic embryos are encapsulated in a suitable matrix (e.g. sodium alginate), along with substances like mycorrhizae, insecticides, fungicides and herbicides. These artificial seeds can be utilized for the rapid and mass propagation of desired plant species as well as hybrid varieties. The major benefits of synthetic seeds are:

- They can be stored up to a year without loss of viability
- Easy to handle and useful as units of delivery
- Can be directly sown in the soil like natural seeds and do not need acclimatization in green house.

Production of secondary metabolites

The most important chemicals produced using cell culture are secondary metabolites, which are defined as 'those cell constituents which are not essential for survival'. These secondary metabolites include alkaloids, glycosides (steroids and phenolics), terpenoids, latex, tannins etc. It has been observed that as the cells undergo morphological differentiation and maturation during plant growth, some of the cells specialize to produce secondary metabolites. The *in vitro* production of secondary metabolites is much higher from differentiated tissues when compared to non-differentiated tissues.

The cell cultures contribute in several ways to the production of natural products. These are:

- A new route of synthesis to establish products e.g. codeine, quinine, pyrethroids
- A route of synthesis to a novel product from plants difficult to grow or establish e.g. thebain from *Papaver bracteatum*
- A source of novel chemicals in their own right e.g. rutacultin from culture of *Ruta*
- As biotransformation systems either on their own or as part of a larger chemical process e.g. digoxin synthesis.

The advantages of *in vitro* production of secondary metabolites

- The cell cultures and cell growth are easily controlled in order to facilitate improved product formation.
- The recovery of the product is easy.

- As the cell culture systems are independent of environmental factors, seasonal variations, pest and microbial diseases, geographical location constraints, it is easy to increase the production of the required metabolite.
- Mutant cell lines can be developed for the production of novel and commercially useful compounds.
- Compounds are produced under controlled conditions as per the market demands.
- The production time is less and cost effective due to minimal labour involved.

Table showing plant species and secondary metabolites obtained from them using tissue culture techniques

Product	Plant source	Uses
Artemisin	<i>Artemisia spp.</i>	Antimalarial
Azadirachtin	<i>Azadirachta indica</i>	Insecticidal
Berberine	<i>Coptis japonica</i>	Antibacterial, anti inflammatory
Capsaicin	<i>Capsicum annum</i>	Cures Rheumatic pain
Codeine	<i>Papaver spp.</i>	Analgesic
Camptothecin	<i>Campatotheca acuminate</i>	Anticancer
Cephalotaxine	<i>Cephalotaxus harringtonia</i>	Antitumour
Digoxin	<i>Digitalis lanata</i>	Cardiac tonic
Pyrethrin	<i>Chrysanthemum cinerariaefolium</i>	Insecticide (for grain storage)
Morphine	<i>Papaver somniferum</i>	Analgesic, sedative
Quinine	<i>Cinchona officinalis</i>	Antimalarial
Taxol	<i>Taxus spp.</i>	Anticarcinogenic
Vincristine	<i>Cathranthus roseus</i>	Anticarcinogenic
Scopolamine	<i>Datura stramonium</i>	Antihypertensive

Anther culture

Plants produced through anther culture are haploids. Doubling the chromosomes without going into series of backcrossing can produce homozygous plants. This technique has profound application to plant breeder and shortens the time of breeding by half.

Embryo rescue

Many important plants are difficult to propagate through seeds. They take a long time for seeds to germinate or the seeds do not germinate at all. This can be overcome through

embryo culture. The seeds are surface sterilized and split open in aseptic condition and the tiny embryo is excised and planted in a nutrient medium and then grows to a complete plant.

Organelle transfer

In some cases, it may be desirable to transfer only organelles or the cytoplasm into a new genetic background. This may be achieved through the use of plant protoplasts. Chloroplasts have been transferred, and other organelles including nucleus may be transferred.

Achievements and future prospects

Tissue culture techniques are being exploited to enhance crop production and to aid crop improvement efforts. Faster clonal multiplication is being exploited on commercial scale for many horticultural species e.g. oil palm, mentha, roses, carnation etc. Tissue cultured somatic tissues are now routinely being used for conservation of those species whose seeds are recalcitrant or ones which do not produce seed at all.

Embryo culture has helped in rescuing hybrid embryos enabling the recovery of many interspecific hybrids and haploid plants. Shoot tip (meristem) culture plays a vital which is of great importance in germplasm exchange, and the development of serological techniques for the detection of viruses in plant materials is a great help to the efforts in this direction.

Questions

- The vegetative propagation of plants is
 - Labour-intensive
 - Low in productivity
 - Seasonal
 - d). All the above**
- Detailed account of stages of micropropagation was given by
 - a). Fossard**
 - Murashige
 - Skoog
 - None of the above
- Detailed account of stages of micropropagation was given by
 - a). Fossard**
 - Murashige
 - Skoog
 - None of the above
- The benefits of micropropagation are
 - Rapid multiplication of superior clones
 - Multiplication of disease free plants
 - Cost effective process
 - d). All the above**
- Somaclonal variation arises as a result of chromosome structural changes like
 - Deletions and duplications
 - Gene mutations
 - Transposons
 - d). All the above**
- The methods involved in the *in vitro* conservation of germplasm are
 - Cryopreservation
 - Cold storage
 - Low pressure and low oxygen storage
 - d). All the above**
- Cryopreservation involves the usage of
 - Solid carbon dioxide (at -79°C)
 - Vapour nitrogen (at -150°C)
 - Liquid nitrogen (at -196°C)
 - d). All the above**
- The major benefits of synthetic seeds are
 - Easy to store without viability loss
 - Easy to handle
 - Can be directly sown in soil
 - d). All the above**
- Tissue culture is used for
 - Vegetative multiplication
 - Virus-free plants

c). **Both a and b**

d). None of the above

10. Tissue culture has potential application in

a). Production of somatic hybrids

b). Organelle and cytoplasm transfer

c). Genetic transformation

d). All the above

11. Virus free plants in tissue culture are produced by

a). Meristem tip culture

b). Shoot tip culture

c). Nodal culture

d). All the above

12. Tissue culture is used for

a). Production of virus free plants

b). Rejuvenation of old plant materials

c). Hybrid production

d). All the above

13. Cryo preservation of tissue culture materials in liquid nitrogen is at

a). -196°C

b). -190°C

c). -96°C

d). -90°C

14. Dimethylsulfoxide is used as in tissue culture.

a). Cryoprotectant

b). Growth regulator

c). Osmoticum

d). None of the above

Additional reading...

http://www.biotechnology4u.com/plant_biotechnology_applications_cell_tissue_culture.html

Somaclonal variation and crop improvement

Larkin and Scowcroft (1981) proposed the term somaclone to describe the plants originating from any type of tissue culture. Genetic variation found to occur between somaclones in plant tissue cultures was called somaclonal variation. This variation includes aneuploids, sterile plants and morphological variants, sometimes involving traits of economic importance in case of crop plants. The usefulness of variation was first demonstrated through the recovery of disease resistant plants in potato (resistance against late blight and early blight) and sugarcane (resistance against eye-spot disease, Fiji disease and downy mildew)

Genetic variation - mutations or other changes in the DNA of the tissue those are heritable. This is only transmitted to the next generation and is thus important for crop improvement. Therefore it is necessary to study the transmission of variation to sexual progeny to facilitate the estimation of its utility for improvement of a sexually propagated crop. In several crops R₀, R₁ and R₂ progenies were analyzed for genetic analyses and 3:1 segregation leading to the isolation of true breeding variants was observed.

Epigenetic variation - non-heritable phenotypic variation. Epigenetic changes can be temporary and are ultimately reversible. However, they may also persist through the life of the regenerated plant.

Physiological variation- temporary in response to stimulus and disappear when it is removed.

Causes for variation

Changes of mother plant origin

Chimeral - rearrangement of tissue layers. Many horticultural plants are periclinal chimeras, that is, the genetic composition of each concentric cell layer (LI, LII, LIII) in the tunica of the meristematic tissues is different. These layers can be rearranged during rapid cellular proliferation. Therefore, regenerated plants may contain a different chimeral composition or may no longer be chimera at all. Cell variation also occurs if callus is initiated from explants containing differentiated and matured tissues that have specialized function.

Explant derived variation

The most stable cultures are obtained from meristematic tissue of a mature plant or tissues of a very young organ of meristematic nature. Polyploid cells can give more variability than diploids

Genetic changes arising in culture

Ploidy changes

Three phenomena that occur during mitosis lead to most changes in ploidy:

- Endomitosis (sister chromatids separate within the nuclear membrane, but there is no spindle formation nor cytoplasmic division)
- Endoreduplication (chromosomes at interphase undergo extra duplications)
- Spindle fusion (giving binucleate or multinucleate cells).

Gross structural rearrangements appear to be a major cause of somaclonal variation.

These involve large segments of chromosomes and so may affect several genes at a time.

- Deletions (genes missing, for example 1,2,3,4 now 1,2,4)
- Inversions (gene order altered, for example 1,2,3,4 now 1,3,2,4)
- Duplications (1,2,3,4 now 1,2,2,3,4)
- Translocations (whole chromosomal segments moved to a new location, for example 1,2,3,4 now 1,2,3,4,A,B,C)

Transposable elements are segments of DNA that are mobile and can insert into coding regions of genes, typically resulting in a lack of expression of the gene. The culture environment may make the transposable elements more likely to excise and move.

Point mutations (the change of a single DNA base), if they take place within a coding region of a gene and result in the alteration of an amino acid, can lead to somaclonal variation. Point mutations are often spontaneous and are more difficult to detect. Note that they result in single gene changes

Structural changes in the DNA sequence

Chromosomal rearrangements, point mutations, or transposition of transposable elements can occur during culture. These changes can occur spontaneously or can be induced with chemicals or radiation

DNA methylation: Most of the mutational events occasioned by tissue culture are directly or indirectly related to alterations in the state of DNA methylation. A decrease in methylation correlates with increased gene activity

Lack of nucleic acid precursors: Shortage of the precursor necessary for rapid nucleic acid biosynthesis, which occurs in many tissue cultures

Growth regulators: One of the triggers of polyploidy *in vitro* is growth regulators; both kinetin and 2,4-D have been implicated.

Composition of culture medium: The level of KNO_3 influences the albino plants from wheat cultures. Level of organic N_2 , chelating agents and other micro nutrients are other factors.

Culture conditions: Temperature, method of culture

Effect of the genotype

Effects of the culture process itself (lengthy culture periods, growth and other aspects of the culture medium may also affect the ploidy of the cultured cells. Medium that places cells under nutrient limitation will favor the development of "abnormal" cells. Chromosomal alterations, like ploidy changes, increase with increased lengths of culture. In mixed populations of cells with different ploidy, diploid cells retain their organogenic potential better than polyploid and aneuploid cells (probably due to an enhanced ability to form meristems).

One common alteration seen in plants produced through tissue culture is *rejuvenation*, especially in woody species. Rejuvenation may lead to changes in morphology, earlier flowering, improved adventitious root formation, and/or increased vigour.

Isolation of somaclonal variants

Mutants for several traits can be far more easily isolated from cell cultures than from whole plant populations. This is because a large number of cells, say 10^6 - 10^9 , can be easily and effectively screened for mutant traits. Screening of as many plants would be very difficult,

ordinarily impossible. Mutants can be effectively selected for disease resistance, improvement of nutritional quality, adaptation of plants to stress conditions, e.g., saline soils, low temperature, toxic metals (e.g., aluminium), resistance to herbicides and to increase the biosynthesis of plant products used for medicinal or industrial purposes. The various approaches to the isolation of somaclonal variants can be grouped into two broad categories: (i) screening and (ii) cell selection.

1. Screening

It involves the observation of a large number of cells or regenerated plants for the detection of variant individuals. This approach is the only feasible technique for the isolation of mutants for yield and yield traits. In general, R1 progeny (progeny of regenerated, R₀, plants) are scored for the identification of variant plants, and their R2 progeny lines are evaluated for confirmation. Screening has been profitably and widely employed for the isolation of cell clones that produce higher quantities of certain biochemicals. Computer based automated cell sorting devices have also been used to screen as many as 1000-2000 cells/second from which desirable variant cells were automatically separated.

2. Cell selection

In the cell selection approach, a suitable selection pressure is applied which permits the preferential survival/growth of variant cells only. Some examples of cell selection are, selection of cells resistant to various toxins, herbicides, high salt concentration etc. When the selection pressure allows only the mutant cells to survive or divide, it is called positive selection. On the other hand, in the case of negative selection, the wild type cells divide normally and therefore are killed by a counter selection agent, e.g., 5 BUdR or arsenate. The mutant cells are unable to divide as a result of which they escape the counter selection agent. These cells are subsequently rescued by removal of the counter selection agent. Negative selection approach is utilized for the isolation of auxotrophic mutants.

The positive selection approach may be further subdivided into four categories: (i) direct selection, (ii) rescue method, (iii) stepwise selection and (iv) double selection.

In direct selection, the cells resistant to the selection pressure survive and divide to form colonies; the wild type cells are killed by the selection agent. This is the most common

selection method. It is used for the isolation of cells resistant to toxins (produced by pathogens), herbicides, elevated salt concentration, antibiotics, amino acid analogues etc.

In the rescue method, the wild type cells are killed by the selection agent, while the variant cells remain alive but, usually, do not divide due to the unfavourable environment. The selection agent is then removed to recover the variant cells. This approach has been used to recover low temperature and aluminium resistant variant cells.

The selection pressure, e.g., salt concentration, may be gradually increased from a relatively low level to the cytotoxic level. The resistant clones isolated at each stage are subjected to the higher selection pressure. Such a selection approach is called stepwise selection. It may often favour gene amplification (which is unstable) or mutations in the organelle DNA.

In some cases, it may be feasible to select for survival and/or growth on one hand and some other feature reflecting resistance to the selection pressure on the other; this is called double selection. An example of double selection is provided by the selection for resistance to the antibiotic streptomycin, which inhibits chlorophyll development in cultured cells. The selection was based on cell survival and colony formation in the presence of streptomycin (one feature) as well as for the development of green colour in these colonies (second feature; only green colonies were selected). This approach has been used for the selection of cells resistant to the herbicide amitrole, 2, 4-D, tobacco mosaic virus (TMV) and aluminium.

Selection of somaclonal variants on subjecting the cells to selection pressure

Selection	Selection of cells in the presence of
Resistance to herbicide	Herbicide
Resistance to salt	Sodium chloride / Aluminium
Resistance to drought	PEG / Mannitol
Resistance to frost	Hydroxy proline resistant lines
Resistance to pathogens	Pathotoxin / Culture filtrate

Crop improvement through somaclonal variation for desirable characters

Crop	Characters modified
Sugarcane	Diseases (eye spot, fiji virus, downy mildew, leaf scald)
Potato	Tuber shape, maturity date, plant morphology, photoperiod, leaf colour, vigour, height, skin colour, Resistance to early and late blight
Rice	Plant height, heading date, seed fertility, grain number and weight
Wheat	Plant and ear morphology, awns, grain weight and yield, gliadin proteins, amylase
Maize	T toxin resistance, male fertility, mt DNA
Medicago sativa	Multifoliate leaves, elongated petioles, growth, branch, no. of plants, dry matter yield.
Tomato	Leaf morphology, branching habit, fruit colour, pedicel, male fertility, growth
Avena sativa	Plant height, heading date, awns
Hordeum spp	Plant height and tillering
Lolium hybrids	Leaf size, flower, vigour, survival

Characterization of variants

Somaclonal variants isolated through cell selection are often unstable. The frequency of stable variants may range from 8-62%, perhaps depending on the species and the selection agent. Many selected clones fail to exhibit their resistance during further screening or selection. Obviously these clones are susceptible and were misclassified as resistant, called as **escapes**. Several clones lose their resistance to the selection agent after a period of growth in the absence of selection pressure. Such clones are called unstable variants and may result from changes in gene expression and from gene amplification (increase in the number of copies of a gene per genome of the organism in comparison to that naturally present). Some variant phenotypes are quite stable during the cell culture phase, but they disappear when plants are regenerated from the variant cultures, or when the regenerated plants reproduce sexually, in case they are expressed in the regenerated plants. Such changes are known as **epigenetic changes** and are attributed to stable changes in gene expression e.g., hormone habituation of cell cultures and, possibly, cold resistance in *Nicotiana sylvestris*.

The remaining variants which stably express the variant phenotypes during the cell culture as well the regenerated plant phases, and exhibit the transmission of these phenotypes through the sexual reproduction cycle are called mutants. Only this category of variants would find an application in crop improvement. These may represent true gene mutations or some other types of changes. Usually, expected mendelian ratios are obtained in the RI progenies. But sometimes aberrant segregation ratios are encountered in RI possibly due to the chimeric nature of Ro plants, the involvement of some cytological anomalies like aneuploidy, deletions etc., gene dosage effects etc.

Achievements

Over a dozen varieties have been developed through the exploitation of somaclonal variation. 'Ono' variety of sugarcane is a Fiji disease resistant somaclone of the susceptible cultivar 'Pindar'. It was identified by screening of plants regenerated from unselected calli. 'Ono' also shows yield advantage over 'Pindar' and has been cultivated to a limited extent in Fiji. A sweet potato cultivar 'Scarlet' was selected from shoot-tip-culture-derived clones. 'Scarlet' is comparable to the parent cultivar in yield and disease resistance, but shows darker and more stable skin colour, which is a desirable quality trait. A geranium variety called 'Velvet Rose' is a somaclone of 'Rober's Lemon Rose'. The new variety has twice the chromosome number of the parent variety. An alfalfa variety called 'Sigma' is a polycross of selected somaclones.

In India, so far somaclonal variation is the only biotechnological approach to give a commercial variety. A somaclonal variant of *Citronella java*, a medicinal plant, has been released as 'Bio-13' for commercial cultivation by CIMAP (Central Institute for Medicinal and Aromatic Plants), Lucknow. Bio-13 yields 37% more oil and 39% more citronellol than the control varieties. A somaclonal variant of the *B. juncea* variety 'Varuna' has been released for commercial cultivation as 'Pusa Jai Kisan'. The new variety has bolder seeds and some yield advantage over the parent variety Varuna.

Advantages

- Somaclonal variations occur in rather high frequencies, which is a great advantage over conventional mutagenesis.

- Some 'new' alleles or even 'new' mutations may be isolated which were not available in the germplasm or through mutagenesis, e.g., joint less pedicel mutant in tomato.
- Use of somaclonal variation may reduce by two years the time required for the release of new variety as compared to mutation breeding. This is because somaclonal variations are usually free from undesirable features like sterility, while induced mutations are generally associated with such defects, which necessitate one or two backcrosses with the parent variety.
- A very effective selection can be practised at the cell level for several traits, e.g., disease resistance etc. This approach effectively selects few desirable cells from among millions with relatively small effort, time, cost and space requirements.
- This is the only approach for the isolation of biochemical mutants, especially auxotrophic mutants, in plants.

Limitations

- The technique is applicable only to those species of cell cultures which regenerate complete plants.
- Selected cell lines often show reduced or no regeneration potential.
- Many selected clones show undesirable features like reduced fertility, growth and even overall performance.

Somaclonal variation represents a useful source of introducing genetic variations that could be of value to plant breeders. Single gene mutation in the nuclear or organelle genome may give the best available variety in vitro that has a specific improved character. In this manner, somaclonal variation could be used to uncover new variants retaining all the favourable characters along with an additional useful trait, such as resistance to diseases or a herbicide. Various cell lines selected in vitro may then prove potentially applicable to agriculture and industry.

Questions

1. The term somaclone was proposed by
a). **Larkin and Scowcroft** b). Skoog
c). Murashige d). None of the above
2. Somaclonal variation includes
a). Aneuploids b). Sterile plants
c). Morphological variants **d). All the above**
3. The usefulness of somaclonal variation was first demonstrated through the recovery of disease resistant plants in
a). Potato b). Sugarcane
c). Both a and b d). None of the above
4. Epigenetic variation includes
a). Non-heritable phenotypic variation b). Temporary
c). Ultimately reversible **d). All the above**
5. Ploidy changes occur due to during mitosis
a). Endomitosis b). Endoreduplication
c). Spindle fusion **d). All the above**
6. Gross structural rearrangements viz., are major cause of somaclonal variation
a). Deletions and duplications b). Inversions
c). Translocations **d). All the above**
7. Ono is a somaclonal variety of
a). Sugarcane b). Geranium
c). Alfa alfa d). Citronella
8. Scarlet is a somaclonal variety of
a). Sugarcane **b). Sweet potato**
c). Alfa alfa d). Citronella
9. Velvet rose is a somaclonal variety of
a). Sugarcane **b). Geranium**
c). Alfa alfa d). Citronella
10. Sigma is a somaclonal variety of

- a). Sugarcane
- c). Alfa alfa**

- b). Geranium
- d). Citronella

11. Bio 13 is a somaclonal variety of

- a). Sugarcane
- c). *Brassica juncea*

- b). Geranium
- d). Citronella**

12. Varuna is a somaclonal variety of

- a). Sugarcane
- c). *Brassica juncea***

- b). Geranium
- d). Citronella

13. Limitation(s) of somaclonal variation is/are

- a). Applicable only to those species which regenerate complete plants out of cell cultures
- b). Reduced or no regeneration potential
- c). Undesirable features like reduced fertility, growth and even overall performance
- d). All the above**

Somatic embryogenesis

The sporophytic generation of a plant is initiated with the zygote, which is the initial cell (product of gamete fusion) that bears all the genetic information to construct the adult individual. In angiosperms, the zygote divides transversally, resulting in two cells. One of them, the apical cell, is small and dense with an intense activity of DNA synthesis. Further ordinal divisions of this cell give rise to the embryo head that will be the new plant. The other resultant cell (basal cell) is a large and highly vacuolated one that will form the suspensor complex, which plays an important role during the early stages of the young embryo. *In vivo*-produced somatic embryos generally follow the same pattern; however, they are not initiated from a zygote, but from a somatic cell as occurs in the polyembryony.

Somatic embryos

Somatic embryos are bipolar structures with both apical and basal meristematic regions, which are capable of forming shoot and root, respectively. A plant derived from a somatic embryo is sometimes referred to as an “embling”.

Somatic embryos vs zygotic embryos and their advantages

Somatic embryos are structurally similar to zygotic embryos found in seeds and possess many of their useful features, including the ability to grow into complete plants. However, somatic embryos differ in that they develop from somatic cells, instead of zygotes (i.e., fusion product of male and female gametes) and thus, potentially can be used to produce duplicates of a single genotype. Since the natural seed develops as a result of a sexual process in cross-pollinating species, it is not genetically identical to one single parent. In contrast, somatic embryo develops from somatic cells (non-sexual) and does not involve sexual recombination. This characteristic of somatic embryos allows not only clonal propagation but also specific and directed changes to be introduced into desirable elite individuals by inserting isolated gene sequences into somatic cells. This bypasses genetic recombination and selection inherent in conventional breeding technology. If the production efficiency and convenience comparable to that of a true seed are achieved, somatic embryos can be potentially used as a clonal propagation system.

Somatic embryogenesis can be initiated by two mechanisms: directly on explanted tissues, where plants are genetically identical (clonation), and indirectly from unorganized tissues (callus). Propagation by indirect embryogenesis carries the risk of producing

plants that may differ genetically from each other and from the parental plant. It is thought that the occurrence of genetic variability within tissue cultures may partly originate from cellular changes that are induced during culture. The genetic variability associated with tissue and cell culture is named "somaclonal variation" and represents an opportunity where selection pressure can be imposed to isolate unique genetic forms of a clone. The ability to recover plants from single cells has made possible the genetic improvement *in vitro*. Plant tolerance to abnormal temperatures, herbicides, fungal toxins, high levels of salt, etc., can be obtained by exposing cell cultures to a selective agent. The most important advantages of the cell- and tissue-culture tools used in plant breeding are:

- Freedom from the effects of the natural environment.
- The ability to handle large numbers of individuals (cells) in very small spaces.
- Creation of variation within cultures. Variability usually occurs spontaneously; however, it can be induced by mutagenic agents.
- Genetic variability can be created deliberately in cultured cells by using genetic-engineering techniques.

Practical applications of somatic embryogenesis

Clonal propagation

Somatic embryogenesis has a potential application in plant improvement. Since both the growth of embryogenic cells and subsequent development of somatic embryos can be carried out in a liquid medium, it is possible to combine somatic embryo-genesis with engineering technology to create large-scale mechanised or automated culture systems. Such systems are capable of producing propagules (somatic embryos) repetitively with low labour inputs. In this process of repetitive somatic embryogenesis (also referred to as accessory, adventive, or secondary somatic embryogenesis) a cycle is initiated whereby somatic embryos proliferate from the previously existing somatic embryo in order to produce clones.

Cloning zygotic embryos for repetitive somatic embryogenesis

A wide range of soybean genotypes have been tested for their ability to undergo auxin-stimulated somatic embryogenesis during cloning of zygotic embryos (Barwale *et al.* 1986; Komatsuda and Ohyama 1988). All of them are reported to form somatic embryos provided appropriate nutrients are provided in the medium. The role of genotypes in conferring regeneration capacity is further supported by studies on zygotic embryo cloning of wheat, rice and maize. Analysis of various cultivars demonstrated that

the regeneration capacity of these crops was directly affected by non-additive, additive and cytoplasmic factors. However, the genotype which has the capacity to undergo repetitive somatic embryogenesis can be back-crossed to elite lines in order to transform the latter with capacity for high regeneration of somatic embryos. Such a type of transformation could play an important role in plant breeding since through in vitro techniques high quality somatic embryos have been produced in 80 species of tropical crops.

Raising somaclonal variants in tree species

Embryos formed directly from pre embryogenic cells appear to produce relatively uniform clonal material, whereas the indirect pathway generates a high frequency of somaclonal variants. Mutation during adventive embryogenesis may give rise to a mutant embryo which on germination would form a new strain of plant. Nucellar embryos, like shoot tips, are free of virus and can be used for raising virus-free clones, especially from some tree species (e.g., poly embryonate Citrus) where shoot tip culture has not been successful. For clonal propagation of tree species, somatic embryogenesis from nucellar cells may offer the only rapid means of obtaining juvenile plants equivalent to seedlings with parental genotype. Clonal propagation through somatic embryogenesis has been reported in 60 species of woody trees representing 25 families. Somatic embryos with genotype of a selected elite parent are potentially convenient organs for cryopreservation and germplasm storage.

Synthesis of artificial seeds

The development of methods for encapsulation of somatic embryos to enable them to be sown under field conditions as 'synthetic' or 'artificial' seed is gaining importance. Research programmes on production of artificial seeds via somatic embryogenesis in respect of commercially important crops would not only contribute to increased agricultural production, but also add to our basic knowledge of the regulatory mechanisms which control plant growth and differentiation.

Source of regenerable protoplast system

Embryogenic callus, suspension cultures and somatic embryos have been employed as sources of protoplast isolation for a range of species. Cells or tissues in these systems have demonstrated the potentiality to regenerate in cultures and, therefore, yield protoplasts that are capable of forming whole plants. Embryogenic cultures are especially

valuable in providing a source of regenerable protoplasts in the graminaceous, coniferous and citrus species. Attempts to achieve regeneration of callus or even sustained divisions in mesophyll-derived protoplasts of Gramineae proved unsuccessful until Vasil and Vasil (1980) turned to embryogenic cultures obtained from immature embryos of pearl millet (*Pennisetum purpureum*) as the source of protoplasts. Protoplasts from these cultures were induced to divide to form a cell mass from which embryoids, and even plantlets, regenerated on a suitable nutrient medium. Similar success was subsequently reported by other workers with embryogenic suspension of *Panicum maximum*, *Pennisetum purpureum*, *Oryza sativa*, *Saccharum officinarum*, *Lolium perenne*, *Festuca arundinaceae* and *Dactylis glomerata*. Among cereals, in Gramineae, the development of a protoplast regeneration system for maize has been especially challenging. Rhodes *et al.* (1988) were the first to raise protoplast derived maize plantlets from embryogenic cultures which, however, proved sterile. Later, Shillito *et al.* (1989) initiated embryogenic callus cultures from immature zygotic embryos of an elite inbred maize line B73, which yielded protoplasts that regenerated to form fertile plants. The protoplast-derived plant on crossing with pollen from a seed-derived plant produced viable seeds which germinated normally. Using similar techniques, Prioli and Sondahl (1989) obtained fertile maize plants from embryogenic cell suspension protoplasts of a line (Cat 100-1) adapted to tropical regions.

Embryogenic citrus suspension cultures also provide protoplasts that can be used in the production of interspecific and intergeneric somatic hybrid plants. Equal success can be obtained with protoplasts isolated from nucellus-callus culture of this plant. Ability to isolate protoplasts from embryogenic cultures has had a large impact on their *in vitro* culture of forest trees, e.g., *Pinus taeda*, *Picea glauca*, *P. mariana*, *Pseudotsuga menziesii*, *Abies alba*, *Santalum album* and *Liriodendron tulipifera*. Somatic embryos induced on the protoplast-derived calli also germinate to form plantlets which finally establish in the soil.

Genetic transformation

In seed embryogenesis, zygotic embryos are seated deep inside the nucellar tissue. They live in a protected environment besides being genetically heterogeneous. On the contrary, somatic embryos remain virtually unprotected and more or less give rise to genetically uniform plants. The advent of leaf-disc transformation systems has made it possible to successfully engineer species (*Nicotiana tabacum*, *Medicago sativa*) in which, tissues are

capable of regeneration *via* somatic embryogenesis.

In these species, isolated single cells can be transformed in cultures and grown on a selection medium (nutrient medium containing an antibiotic, kanamycin) to callus colonies which eventually form somatic embryos on removal of auxin from this medium (Chabaud *et al.*, 1988). Since the callus phase seems essential in this type of indirect somatic embryogenesis, the possibility of chimeric embryos arising from transformed and non-transformed tissues cannot be ruled out. Therefore, the callus phase can be bypassed through a process of repetitive somatic embryogenesis. McGranahan *et al.* (1990) used repetitive embryogenesis for *Agrobacterium*-transformed walnut (*Juglans regia* L.) cells and obtained multiple crops of somatic embryos without employing the callus phase.

There is also evidence to show that repetitive embryos originate from single epidermal or subepidermal cells which can be readily exposed to *Agrobacterium*. Thus, the transformation technique applied to a primary somatic embryo, instead of a zygotic embryo, should give rise to totally transgenic somatic embryos. Repetitive embryogenesis is also ideally suited to particle gun-mediated genetic transformation. Instead of relying on *Agrobacterium* to mediate the transfer of genes into plant cells, the particle gun literally shoots DNA that has been precipitated onto particles of a heavy metal, into the plant cells. Embryogenic suspension cultures of cotton and soybean, initiated from immature embryos, yielded an average of 30 stably transformed cell lines following each firing of the gun. The transformed cell lines can then be induced to form an unlimited number of transformed somatic embryos through repetitive embryogenesis.

Synthesis of metabolites

The repetitive embryogenesis system is of potential use in the synthesis of metabolites such as pharmaceuticals and oils. Borage (*Borage officinalis* L.) seeds contain high levels of γ -linolenic acid, used in the treatment of atopic eczema. Somatic embryos of borage also produce this metabolite but through repetitive somatic embryogenesis a continuous supply of γ -linolenic acid is ensured, which otherwise would be limited to the growing season in the zygotic embryo. The same principle can be applied for production *in vitro* of industrial lubricants from jojoba (*Simmondsia chinensis*) and leo-palmitostearin (the major ingredient in cocoa butter) from Cacao (*Theobroma cacao*).

The *in vivo* clonal propagation of plants is often difficult, expensive and even unsuccessful. Tissue culture methods offer an alternative means of plant vegetative propagation. Clonal propagation through tissue culture (popularly called micropropagation) can be achieved in a short time and space. This is possible through somatic embryogenesis by which rapid formation of embryos takes place leading to multiplication of shoots.

Synthetic seed production

Need for artificial or synthetic seed production technology

Development of micropropagation techniques will ensure abundant supply of the desired plant species. In some crop species seed propagation has not been successful. This is

Box 1. Characteristics of Clonal Propagation Systems

Micropropagation

- Low volume, small scale propagation method
- Maintains genetic uniformity of plants
- Acclimatisation of plantlets required prior to field planting
- High cost per plantlet
- Relatively low multiplication rate

Greenhouse cuttings

- Low volume, small scale propagation method
- Maintains genetic uniformity of plants
- Rooting of plantlets required prior to field planting
- High cost per plantlet
- Multiplication rate limited by mother plant size

Artificial seeds

- High volume, large scale propagation method
- Maintains genetic uniformity of plants
- Direct delivery of propagules to the field, thus eliminating transplants
- Lower cost per plantlet
- Rapid multiplication of plants.

mainly due to heterozygosity of seed, minute seed size, presence of reduced endosperm and the requirement of seed with mycorrhizal fungi association for germination (eg. orchids), and also in some seedless varieties of crop plants like grapes, watermelon, etc. Some of these species can be propagated by vegetative means. However, *in vivo* vegetative propagation techniques are time consuming and expensive. Development of

artificial seed production technology is currently considered as an effective and efficient alternate method of propagation in several commercially important agronomic and horticultural crops. It has been suggested as a powerful tool for mass propagation of elite plant species with high commercial value. Characteristics of clonal propagation systems are discussed in Box 1.

Artificial seed technology involves the production of tissue culture derived somatic embryos encased in a protective coating. Artificial seeds have also been often referred to as synthetic seeds. However, the term synthetic seed should not be confused with commercial seeds of a synthetic cultivar which is defined as an advanced generation of an open pollinated population composed of a group of selected inbred clones or hybrids. The concept of artificial or synthetic seed is shown in Figure.

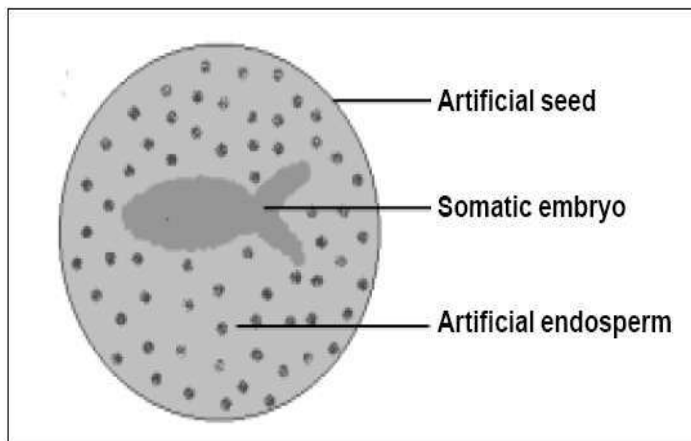

These synthetic seeds would also be a channel for new plant lines produced through biotechnological advances to be delivered directly to the greenhouse or field. Advantages of artificial/synthetic seeds over somatic embryos for propagation are listed in Box 2. This synthetic

seed production technology is a high volume, low-cost production technology. High volume propagation potential of somatic embryos combined with formation of synthetic seeds for low-cost delivery would open new vistas for clonal propagation in several commercially important crop species.

Box.2. Advantages of Artificial or Synthetic Seeds over Somatic Embryos for Propagation

- Ease of handling while in storage
- Easy to transport
- Has potential for long term storage without losing viability
- Maintains the clonal nature of the resulting plants
- Serves as a channel for new plant lines produced through biotechnological advances to be delivered directly to the greenhouse or field
- Allows economical mass propagation of elite plant varieties.

Basic requirement for production of artificial seeds

Recently, production of synthetic seeds by encapsulating somatic embryos has been reported in few species. One prerequisite for the application of synthetic seed technology in micropropagation is the production of high-quality, vigorous somatic embryos that can produce plants with frequencies comparable to natural seeds. Inability to recover such embryos is often a major limitation in the development of synthetic seeds.

Synthetic seed technology requires the inexpensive production of large numbers of high quality somatic embryos with synchronous maturation. The overall quality of the somatic embryos is critical for achieving high conversion frequencies. Encapsulation and coating systems, though important for delivery of somatic embryos, are not the limiting factors for development of synthetic seeds.

At present, the characteristic lack of developmental synchrony in embryogenic systems stymies multi-step procedures for guiding somatic embryos through maturation. The lack of synchrony of somatic embryos is, arguably, the single most important hurdle to be overcome before advances leading to widespread commercialization of synthetic seeds can occur. Synchronized embryoid development is required for the efficient production of synthetic seeds.

Procedure for production of artificial seeds

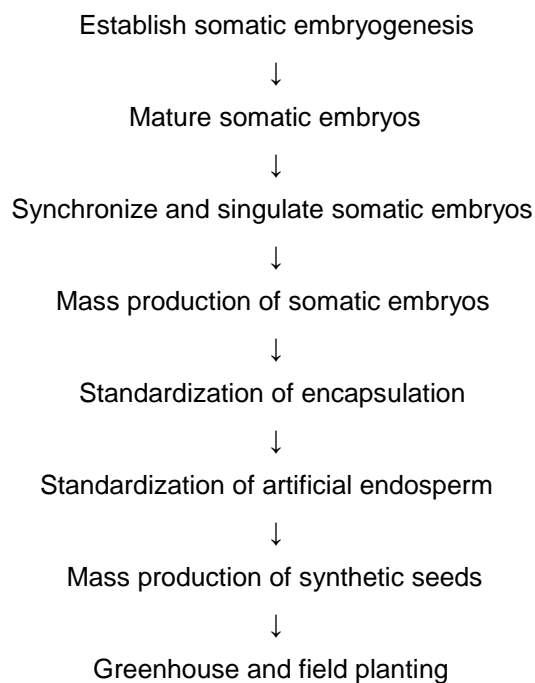

Types of somatic embryos

Two types of artificial seeds have been developed, namely, hydrated and desiccated. Redenbergh et al. (1986) developed hydrated artificial seeds by mixing somatic embryos of alfalfa, celery and cauliflower with sodium alginate, followed by dropping into a solution of calcium chloride to form calcium-alginate beads. The beads become hardened as calcium alginate is formed. After about 20-30 min. the artificial seeds are removed, washed with water and used for planting. Hydrated artificial seeds are sticky and difficult to handle on a large scale, dry rapidly in the open air. These problems can be resolved by providing a waxy coating over the beads. However, it is not possible to store, except at low temperatures and for limited periods, hydrated artificial seeds and they have to be planted soon after they are produced. Precision machines for large scale encapsulation of SEs have been devised.

Kim and Janick (1989) applied synthetic seed coats to clumps of carrot somatic embryos to develop desiccated artificial seeds. They mixed equal volumes of embryo suspension and 5% solution of polyethylene oxide (polyox WSR N-750), a water-soluble resin, which subsequently dried to form polyembryonic desiccated wafers. The survival of encapsulated embryos was further achieved by embryo hardening treatments with 12% sucrose or 10⁻⁶M ABA, followed by chilling at high inoculum density.

Another delivery system for somatic embryos for obtaining transgenic plants is Fluid-drilling. Embryos are suspended in a viscous-carrier gel which extrudes into the soil. The primary problem in fluid-drilling is that the sucrose level necessary to permit conversion also promotes rapid growth of contaminating micro-organisms in a non-aseptic system. Gray (1987) found that somatic embryos of orchard grass (*Dactylis glomerata*) became quiescent when desiccated in empty plastic petri dishes at 70% relative humidity at 23°C which amounted to loss of 13% water. However, after 21 days of storage, desiccated embryos when rehydrated *in vitro* germinated to produce viable plantlets though limited (4%) in number. Senaratna *et al* (1990) treated alfalfa somatic embryos with ABA at the torpedo to cotyledonary stages in order to increase their tolerance to desiccation. Over 60% of such desiccated embryos germinated when placed on a moist filter paper or sown directly onto sterile soil and formed plantlets. Heat-shock treatments also induced a degree of desiccation tolerance comparable to that conferred by ABA treatment and had no detrimental effect on the subsequent growth of the plantlets.

In general, the gels contain inorganic nutrients, a carbon source, fungicides, bactericides

and other growth promoting substances necessary for SE germination and seedling establishment in the field. When shoot buds are encapsulated, growth regulators needed for rooting and shoot growth are also included. The SE must be of good quality to be able to germinate in a high frequency under field/ greenhouse conditions. Alfalfa is the most extensively investigated plant species in this regard.

Types of gelling agents used for encapsulation

Several gels like agar, alginate, polyco 2133 (Bordon Co.), carboxy methyl cellulose, carrageenan, gelrite (Kelko. Co.), guar gum, sodium pectate, tragacanth gum, etc. were tested for synthetic seed production, out of which alginate encapsulation was found to be more suitable and practicable for synthetic seed production. Alginate hydrogel is frequently selected as a matrix for synthetic seed because of its moderate viscosity and low spin ability of solution, low toxicity for somatic embryos and quick gelation, low cost and bio-compatibility characteristics. The use of agar as gel matrix was deliberately avoided as it is considered inferior to alginate with respect to long term storage. Alginate was chosen because it enhances capsule formation and also the rigidity of alginate beads provides better protection (than agar) to the encased somatic embryos against mechanical injury. Alginate encapsulated somatic embryos of orchids are shown in Figure 1 and the plantlets derived from artificial or synthetic seeds of orchid are shown in Figure 2.



Figure 1 (left). Artificial or synthetic seed produced in orchids by alginate encapsulation.

Figure 2 (right). Artificial or synthetic seed derived plantlets in orchid.

Principle and conditions for encapsulation with alginate matrix

Alginate is a straight chain, hydrophilic, colloidal polyuronic acid composed primarily of hydro- α -D-mannuronic acid residues with 1-4 linkages. The major principle involved in the alginate encapsulation process is that the sodium alginate droplets containing the

somatic embryos when dropped into the $\text{CaCl}_2 \cdot 2\text{H}_2\text{O}$ solution form round and firm beads due to ion exchange between the Na^+ in sodium alginate with Ca^{2+} in the $\text{CaCl}_2 \cdot 2\text{H}_2\text{O}$ solution. The hardness or rigidity of the capsule mainly depends upon the number of sodium ions exchanged with calcium ions. Hence, the concentration of the two gelling agents i.e., sodium alginate and $\text{CaCl}_2 \cdot 2\text{H}_2\text{O}$, and the complexing time should be optimized for the formation of the capsule with optimum bead hardness and rigidity. In general, 3% sodium alginate upon complexation with 75 mM $\text{CaCl}_2 \cdot 2\text{H}_2\text{O}$ for half an hour gives optimum bead hardness and rigidity for the production of viable synthetic seeds.

Artificial endosperm

Somatic embryos lack seed coat (testa) and endosperm that provide protection and nutrition for zygotic embryos in developing seeds. To augment these deficiencies, addition of nutrients and growth regulators to the encapsulation matrix is desired, which serves as an artificial endosperm. Addition of nutrients and growth regulators to the encapsulation matrix results in increase in efficiency of germination and viability of encapsulated somatic embryos. These synthetic seeds can be stored for a longer period of time even up to 6 months without losing viability, especially when stored at 4 °C.

Addition of adjuvants to the matrix

In addition to preventing the embryo from desiccation and mechanical injury, a number of useful materials such as nutrients, fungicides, pesticides, antibiotics and microorganisms (eg. rhizobia) may be incorporated into the encapsulation matrix. Incorporation of activated charcoal improves the conversion and vigour of the encapsulated somatic embryos. It has been suggested that charcoal breaks up the alginate and thus increases respiration of somatic embryos (which otherwise lose vigour within a short period of storage). In addition, charcoal retains nutrients within the hydrogel capsule and slowly releases them to the growing embryo.

Utilization of artificial seeds

The artificial seeds can be used for specific purposes, notably multiplication of non-seed producing plants, ornamental hybrids (currently propagated by cuttings) or the propagation of polyploid plants with elite traits. The artificial seed system can also be employed in the propagation of male or female sterile plants for hybrid seed production. Cryo-preserved artificial seeds may also be used for germplasm preservation, particularly in recalcitrant species (such as mango, cocoa and coconut), as these seeds will not

undergo desiccation. Furthermore, transgenic plants, which require separate growth facilities to maintain original genotypes may also be preserved using somatic embryos. Somatic embryogenesis is a potential tool in the genetic engineering of plants. Potentially, a single gene can be inserted into a somatic cell. In plants that are regenerated by somatic embryos from a single transgenic cell, the progeny will not be chimeric. Multiplication of elite plants selected in plant breeding programs via somatic embryos avoids the genetic recombination, and therefore does not warrant continued selection inherent in conventional plant breeding, saving considerable amount of time and other resources. Artificial seeds produced in tissue culture are free of pathogens. Thus, another advantage is the transport of pathogen free propagules across the international borders avoiding bulk transportation of plants, quarantine and spread of diseases.

Potential uses of artificial seeds

Delivery systems

- Reduced costs of transplants
- Direct greenhouse and field delivery of:
 - Elite, select genotypes
 - Hand-pollinated hybrids
 - Genetically engineered plants
 - Sterile and unstable genotypes
- Large-scale mono cultures
- Mixed-genotype plantations
- Carrier for adjuvants such as microorganisms, plant growth regulators pesticides, fungicides, nutrients and antibiotics
- Protection of meiotically-unstable, elite genotypes
- Can be conceivably handled as seed using conventional planting equipment.

Analytical tools

- Comparative aid for zygotic embryogeny
- Production of large numbers of identical embryos
- Determination of role of endosperm in embryo development and germination
- Study of seed coat formation
- Study of somaclonal variation.

Applicability and feasibility of artificial seed production technology

In order to be useful, synthetic seed must either reduce production costs or increase crop value. The relative benefits gained, when weighed against development costs, will determine whether its use is justified for a given crop species. Considering a combination of factors, including improvement of the existing embryogenic systems, relative cost of seed as well as specific application for synthetic seed allows judgement of relative need for a given crop. For example, synthetic seed of seedless watermelon would actually cost less than conventional seed, providing a benefit at the outset of crop production. Although embryogenic systems for this crop do not exist, the benefit that could be conferred by use of synthetic seed would be very great. Value added aspects that would increase crop worth are numerous and include cloning of elite genotypes, such as genetically engineered varieties, that cannot produce true seed.

Questions

1. A plant derived from a somatic embryo is referred as
 - a). Seedling
 - b). Embling
 - c). Both a and b
 - d). None of the above
2. Somatic embryos are
 - a). Bipolar structures
 - b). Have apical and basal meristematic regions
 - c). Capable of forming shoot and root
 - d). All the above**
3. Synthetic seeds are of types
 - a). Hydrated
 - b). Dessicated
 - c). Both a and b**
 - d). None of the above
4. Hydrated synthetic seeds are developed by
 - a). Redenbergh**
 - b). Kim and Janick
 - c). Both a and b
 - d). None of the above
5. Dessicated synthetic seeds are developed by
 - a). Redenbergh
 - b). Kim and Janick**
 - c). Both a and b
 - d). None of the above
6. Hydrated artificial seeds are
 - a). Sticky
 - b). Dry rapidly in the open air
 - c). Difficult to handle on a large scale
 - d). All the above**
7. Gels used for synthetic seed production includes.....
 - a). Agar and alginate
 - b). Polyco 2133
 - c). Carboxy methyl cellulose
 - d). All the above**
8. Gels used for synthetic seed production includes.....
 - a). Carrageenan and gelrite
 - b). Sodium pectate
 - c). Guargum
 - d). All the above**
9. Alginate hydrogel is frequently selected as a matrix for synthetic seed because of its
 - a). moderate viscosity and low spin ability of solution
 - b). low toxicity for somatic embryos and quick gelation
 - c). low cost and bio-compatibility characteristics
 - d). All the above**

10. Gels used for synthetic seed production includes.....
- a). Carrageenan and gelrite
 - b). Sodium pectate
 - c). Guargum
 - d). All the above**
11. Incorporation of activated charcoal in synthetic seed coating improves
- a). Conversion and vigour of the encapsulated somatic embryos
 - b). Increases respiration of somatic embryos
 - c). Retains nutrients within the hydrogel capsule and slowly releases them to the growing embryo
 - d). All the above**
12. The artificial seeds can be used for specific purposes viz.,
- a). Multiplication of non-seed producing plants
 - b). Propagation of male or female sterile plants for hybrid seed production
 - c). Propagation of polyploid plants with elite traits
 - d). All the above**

Protoplast isolation

In eukaryotes the transfer of genetic material from one individual to another is conventionally achieved through sexual breeding. In plants, where fairly distant species could be crossed, it has not always been possible to obtain full hybrids between desired individuals because of sexual incompatibility barriers. In this respect cell fusion offers a novel approach to distant hybridization through somatic hybridization. Fusion of cells must occur through the plasma membrane. Unlike animals, in plants the plasma membrane is bound by a rigid cellulosic wall and the adjacent cells are cemented together by a pectin rich matrix. That's why somatic cell genetics is more advanced in animals than plants. In 1960, E. C. Cocking demonstrated the feasibility of enzymatic degradation of plant cell walls to obtain large quantities of viable naked cells – called as protoplasts.

Besides being able to fuse with each other, higher plant protoplasts can also take up foreign DNA, through their naked plasma membrane under specific chemical and physical treatments. Protoplasts also provide an experimental system for a wide range of biochemical and molecular studies ranging from investigations into the growth properties of individual cells to membrane transport.

Isolation of protoplast

1. Mechanical method

Klecker in 1892 has first initiated the protoplast isolation by mechanical means- the cells were kept in a suitable medium plasmolyticum and cut with a fine knife. In this process some of the plasmolyzed cells were cut only through the cell wall, releasing intact protoplasts.

Principle of Mechanical Method Isolation when tissue is cut along the dotted line, with a razor blade, some protoplasts will be released

A. Tissue is cut along the dotted line B. Release of Protoplasts from Damaged cells

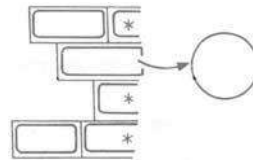
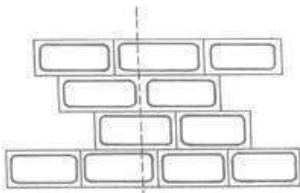

Limitation

1. Applicable only to vacuolated cells
2. Yields are extremely low.

2. Enzymatic method

In 1960, Cocking used a concentrated solution of cellulase enzyme, prepared from cultures of the fungus, *Myrothecium verrucaria*, to degrade the cell walls.

However, real progress in this area was made after 1968 when cellulase and macerozyme enzymes became commercially available. The commercial preparations of the enzymes for protoplast isolation were first employed by Takebe *et al.*, (1968). The tobacco leaf species were first exposed to macerozyme to liberate single cells which were then treated with cellulase to digest the cell walls and release the protoplasts. Later, these two enzymes were used together and this is found as faster method and also reduces the chances of microbial contamination by cutting down a few steps.

Isolation of Mesophyll Protoplasts Using Leaves with Epidermis Peeled Off

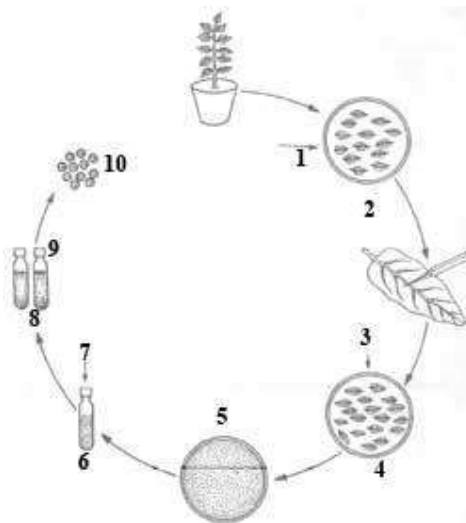

1. Leaves, 2. Sterilization of leaves, 3. Removal of epidermis by peeling, 4. Peeled leaves in enzyme solution, 5. Released protoplasts in enzyme solution, 6. Protoplasts in washing medium, 7. Centrifugation, 8. Cell debris, 9. Protoplasts and 10. Isolated protoplasts

Table: Some commonly used commercially available enzymes for protoplast isolation

Enzymes	Source
<u>Cellulases</u>	
Onozuka RS	<i>Trichoderma viride</i>
Cellulase R-10	<i>T. viride</i>
<u>Hemicellulase</u>	
Hemicellulase	<i>Aspergillus niger</i>
Rhozyme HP150	<i>A. niger</i>
<u>Pectinase</u>	
Macerozyme R-10	<i>Rhizopus</i> spp.
Macerase	<i>Rhizopus</i> spp.

A range of enzyme preparations are now available commercially and depending on the nature of the tissue these are used in different combinations. The use of commercially available enzymes has enabled the isolation of protoplasts from virtually every plant tissue as long as cells have not acquired lignification. Protoplast isolation has been reported from mesophyll cells of in vivo and in vitro growing plantlets, aseptic seedlings, microspore mother cells, young microspores, pollen grain calli and embryogenic and non-embryogenic suspension cultures. More recently, viable protoplasts have been obtained from male and female gametes.

Direct method - In one step method, the leaf segments are incubated overnight (15-18h) with enzyme mixture at 25°C and teased gently to liberate the protoplasts. The mixture is filtered through fine wire gauze to remove leaf debris, transferred to 13 × 1000 mm screw capped tubes and centrifuged at 100g for 1 min.

The protoplasts form a pellet and supernatant removed. The process is repeated three times and protoplasts washed with 13% Sorbitol solution, which is later replaced by 20% sucrose solution. The protoplasts suspension is centrifuged at a speed of 200g for 1 min. The cleaned protoplasts, that are floating (debris settles down), can be pipetted out and bulked.

Sequential method - In two step method, leaf segments with mixture A (0.5% macerozyme + 0.3% potassium dextran sulphate in 13% mannitol at pH 5.8) are vacuum infiltrated for 5 min; transferred to a water bath at 25°C and subjected to slow shaking.

After 15 min. the enzyme mixture is replaced by fresh 'enzyme mixture A' and leaf segments incubated for another hour. The mixture is filtered using nylon mesh, centrifuged (100g) for 1 min. and washed three times with 13% mannitol to get a pure sample of isolated cells.

These cells are then incubated with 'enzyme mixture B' (2% cellulase in a 13% solution of mannitol at pH 5.4) for above 90 min at 30°C. After incubation, the mixture is centrifuged at 100g for 1 min, so that protoplasts form a pellet, which is cleaned three times as in 'one step method' above.

Factors affecting yield and viability of protoplasts

Source of material

Leaf has been the most favorite source of plant protoplasts because it allows the isolation of a large number of relatively uniform cells without the necessity of killing the plants. Since the mesophyll cell is loosely arranged, the enzymes have an easy access to the cell wall. The leaves from in vitro roots or shoots released twice as many viable protoplasts as the leaves from field grown material. Owing to the difficulty in isolating culturable protoplasts from leaf cells of cereals and other species, their cultured cells have been used as an alternative source material.

Pre enzyme treatment

The lower epidermis is peeled and floats the stripped pieces of leaf on the enzyme in manner that the peeled surface is in contact with the solution. This will facilitate easy penetration of enzyme in to intercellular spaces of leaf. Mesophyll protoplasts of cereals could be isolated within 2 hr by infiltrating the leaf pieces with enzyme solution under a partial vacuum for 3-5 min. The criterion used to check adequate infiltration is that leaf pieces will sink when the vacuum is removed. Brushing the leaf with a soft brush or with the cutting edge of scalpel may also improve enzymatic action.

Enzyme treatment

The two enzymes, essential to isolate protoplasts from plant cells are cellulase and pectinase. Pectinase degrades mainly the middle lamella and the cellulase required to digest the cellulosic cell wall. The crude commercial enzymes carry nucleases and proteases as impurities which may be harmful to protoplasts viability. The activity of the enzymes is pH dependant and it is also affected by the temperature. The optimal temperature for the activity of these enzymes is

40-50°C which happens to be too high for the cells. Generally 25-30°C is found adequate for isolation of protoplasts.

Osmoticum

A fundamental property of isolated protoplasts is their osmotic fragility and hence, there is a need for a suitable osmotic stabilizer in the enzyme solution, the protoplast medium and the protoplast culture medium. Protoplasts are more stable in a slightly hypertonic rather than isotonic solution. A higher level of the osmoticum may prevent bursting and budding but it may inhibit the division of the protoplast. The most widely used osmotica are sorbitol and mannitol in the range of 450-800 mmol.

Culture of protoplasts

The methods used for protoplasts culture are basically the same as those employed for other tissue and cell culture. Protoplasts can be cultured on liquid or solid agar media to meet special requirements. In the following section, a wide range of available culture methods are described.

Culturing in liquid media

Liquid cultures

The protoplasts are suspended in a small volume of liquid culture medium at an appropriate density and placed in petri dishes, which are then sealed with parafilm to reduce the loss of water from the culture medium. The advantage of liquid culture is that it allows gradual change of the osmolarity of the culture medium and in this way promotes rapid cell regeneration. This method requires relatively large volumes of protoplast suspension. If small volumes of protoplasts have to be cultured, one of the following methods can be adopted.

Drop cultures

Small droplets (40 to 100 μ l) of protoplasts suspension are placed on the inner side of the lid of a petri dish. When the lid is covered on the bottom, the culture drops are changed towards the bottom dish. To the dish, fresh medium can be added in small drops when required.

Microchamber cultures

Microchamber cultures are similar to hanging drop cultures and are adopted for individual protoplast culture. A drop of protoplast suspension is placed on sterile cover glass and inverted

on the slide with microchamber. Microchamber culture offers an optically better view since the depth of the chamber is kept at minimum.

Multiple drop array technique

In drop culture technique, five to ten relatively large drops are placed on the petri dish. In the multiple drop array technique, the drop is reduced to 40 μ l so that 50 drops can be placed in a single petri dish. This method is used to screen a wide range of nutritional and hormonal factors.

Microdroplet cultures

Microdroplet culture is used to culture individual protoplasts. For this technique, the size of drops is reduced to 0.25 to 0.50 μ l so that each droplet contains only one protoplast and special cups or petri dishes are used.

Culturing on semi-solid media

Agar as gelling agent

The protoplast suspension is mixed with equal volume of melted agar medium kept at about 43 to 45°C. Actually the agar plating technique was originally used for the plating of cell suspension cultures and the method was later modified and applied to protoplast culture.

Agarose or Alginate as gelling agent

Solidification of media with agarose instead of agar improves the protoplast culture efficiency. The improved efficiency of the agarose may be due to the absence of contaminating substances and neutrality. Protoplasts are plated in thin layers of agarose on top of already poured and solidified media in petri dishes.

Combination of liquid and solid media

Gel embedded protoplast cultures

The protoplasts are incorporated into the whole medium before plating. The gelled agar or agarose with protoplasts is then cut into several blocks, which are transferred to large volumes of liquid culture medium and placed on shaker.

Semi-solid media for liquification

Semi-solid media prepared of agar or agarose are generally used. In this type of culture, protoplasts are plated on semi-solid media. The semi-solid media with protoplasts are remelted at 40°C for 1 or 2 hours to recover protoplasts for further multiplication.

Different feeder techniques

In protoplast culture, minimum-plating density (mpd) is an important factor. The **mpd** can be maintained at low level by using the following techniques.

Feeder layers

A layer mixture of protoplasts of different species is plated on an agar-solidified medium. The protoplasts are subject to irradiation to inactivate but not kill the layer of protoplasts. This layer is called feeder layer. Then the protoplasts to be cultured can be plated at lower density of 5 - 50 protoplasts/cm³.

Nurse cultures

In nurse culture technique, protoplasts of one or more species grown on a medium support the growth of other species i.e., protoplasts can be cultured on an established protoplast culture. Generally this is followed to culture the fusion products of two different protoplasts.

Reservoir media

Protoplasts are cultured in quadrante plates. The liquid medium is placed in two quadrates and protoplast suspension in other two quadrates of the plate. The continuous leakage of medium keeps up the viability of protoplasts.

Use of filter paper discs

A filter paper disc is placed on an agar medium over which protoplast suspension is poured. The filter paper provides a physical support to the protoplasts and absorbs unwanted toxic substances.

Purification of protoplasts

After the material has been incubated in enzymes solution for an adequate period the incubation vessel is gently swirled or the leaf pieces are gently squeezed to release the protoplasts held in the original tissue. The digestion mixture consists of sub cellular debris,

especially chloroplasts, vascular elements, undigested cells and broken protoplasts besides intact and healthy protoplasts. The protoplasts isolated as above are present in the media together with a range of cell debris and broken cell organelles. A number of methods are available for purification of protoplasts from this mixture. Only two commonly used methods are briefly described.

Sedimentation and washing

In this method, the crude protoplasts suspension is centrifuged at low speed (50-100g for 5 min). The intact protoplasts form a pellet and supernatant containing cell debris can be pipetted off. The pellet is gently resuspended in fresh culture media plus mannitol and rewashed. This process is repeated two or three times to get relatively clean protoplast preparation.

Protoplasts can be purified by repeated gentle pelleting and resuspension

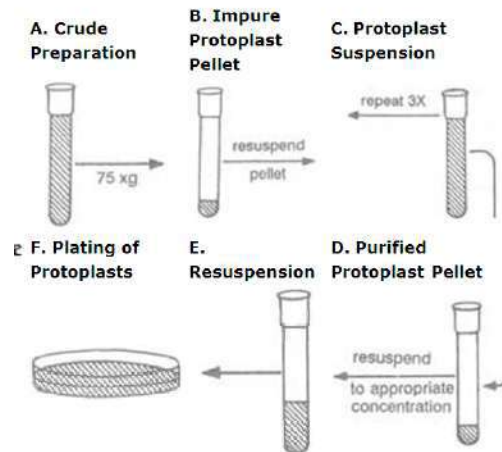

Flotation

Protoplasts being lighter (low density) than other cell debris, gradients may be used, which will allow the protoplasts to float and the cell debris to sediment.

A concentrated solution of mannitol, Sorbitol and sucrose (0.3-0.6M) can be used as a gradient and crude protoplasts suspension may be centrifuged in this gradient at an appropriate speed. Protoplasts can be pipetted off from the top of the tube after centrifugation.

This method causes little loss or damage relative to that in the 'sedimentation and washing' method. **Babcock bottle** is also used for flotation, since it facilitates removal of protoplasts.

Flotation of the protoplasts in a Babcock bottle greatly eases the removal of purified protoplasts from the sucrose cushion

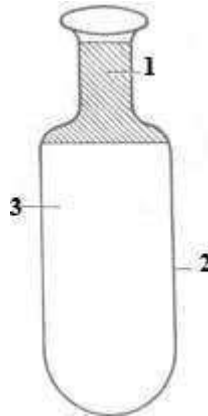

1. Protoplasts, 2. Babcock bottle, 3. Flotation cushion

Viability of the protoplasts

Viability of the freshly isolated protoplasts can be checked by a number of methods:

- ✓ Observation of cyclosis or cytoplasmic streaming as an indication of active metabolism.
- ✓ Oxygen uptake measured by an oxygen electrode which indicated respiratory metabolism.
- ✓ Photosynthetic activity
- ✓ Exclusion of Evan's blue dye by intact membranes
- ✓ Staining with fluorescein diacetate- which is most commonly used.

Protoplast culture

Protoplasts may be cultured in agar plates. An advantage in using semi-solid medium is that the protoplasts remain stationary which makes it convenient to follow the development of specific individuals. However, liquid medium has been generally preferred for the following reasons:

1. The osmotic pressure of the medium can be effectively reduced after a few days of culture
2. Protoplasts of some species would not divide if plated in agarified medium.

3. If the degenerating component of the protoplast population produces some toxic substances which could kill the healthy cells it is possible to change the medium.
4. The density of cells can be reduced or cells of special interest may be isolated after culturing them for a few days at a high density.

The protoplasts suspension is plated as a thin layer in petriplates, or incubated as static cultures in flasks or distributed in 50-100 μ l drops in petri plates and stored in a humidified chamber. Embedding protoplasts in agarose beads or discs is reported to improve plating and regeneration efficiency in many species. Alginate is another gelling agent used for culture of protoplasts, particularly of the species, which are heat sensitive such as *Arabidopsis thaliana*. After 2-4 days in culture, protoplasts lose their characteristic spherical shape and this has been taken as an indication of new wall regeneration. While the presence of a proper wall is essential for regular division, not all such cells regenerated from protoplasts embark upon division. In protoplast cultures, the cell divisions are asynchronous. The first division may be equal or unequal. Mitosis is normal. Continuous cell division leads to callus formation and the plant will be regenerated through normal developmental process.

Plant regeneration

Protoplasts, thus cultured undergo the following processes to produce plantlets. They are:

- Cell wall formation
- Cell division and callus formation
- Plant regeneration

Cell wall formation

Protoplasts in culture start to regenerate cell wall within a few hours, and may take two to several days to complete it. Within 2-4 days in culture, protoplasts lose their characteristic spherical shape and this has been taken as an indication of new wall regeneration. The wall synthesis by protoplasts starts immediately after the enzyme is washed off. During cell wall formation, the cellulose is deposited either between plasmalemma and multilamellar wall material or directly on the plasmalemma. A freshly formed cell wall is composed of loosely arranged microfibrils, which subsequently become organised to form a typical cell wall. The protoplasts may start cell wall synthesis 10-20 minutes after culture or go without cell wall for over a period of seven days. The protoplasts with normal cell wall undergo mitosis and produce

daughter cells. The protoplasts with poorly formed cell walls do not undergo normal mitosis, but fuse with each other to produce multinucleate cells or enlarge in size to undergo budding.

Cell division and callus formation

Normally after cell wall regeneration, the cell undergoes a significant increase in size. This is followed by first mitotic division. Immediately after first division, the protoplasts may undergo a lag phase, which lasts for 7-25 days. Generally, protoplasts of actively growing cell suspensions undergo first division faster than those from mesophyll protoplasts. The second round of divisions is often observed within a week of the first division. Small cell clumps form within two weeks of second division producing small pieces of callus.

Plant regeneration

The general techniques applicable to plant regeneration from tissue cultures hold good for the callus obtained from protoplasts also. The first step for the regeneration of plants involved the transference of callus to regeneration medium containing balanced phytohormones either to induce organogenesis or somatic embryogenesis. The first report of plant regeneration from isolated protoplasts was from *Nicotiana tabacum* by **Takebe et al.**, in 1971. Since then the list of species exhibiting this potentiality had steadily increased.

Applications

Virus uptake: Studies on the mechanism of infection and host parasite relationships

Bacterial uptake: Symbiotic nitrogen fixing bacterium (*Rhizobium*, *Azotobacter*) can be introduced into legume. Direct DNA transfer and expression of a bacterial gene in protoplasts of exogenous DNA by cells or protoplasts of *T. Monococcum* and *N. tabacum* are reported.

Incorporation of Cyanobacterial cells (e.g.): Cyanobacteria or BGA. Co-incubate algal preparation with isolated protoplasts with 25% PEG and high planting density. Protoplasts begin engulf algal cells.

Incorporation of exogenous DNA: Exogenous DNA can be taken up by higher plant cells/protoplasts and this is known as Transgenosis.

Transplantation of nuclei: Organelles such as large nuclei can be introduced through plasma lemma into protoplasts. Both intra and inter specific nuclear transplantations have been observed in *Petunia hybrida*, *Nicotiana tabacum* and *Zea mays*.

Protoplast fusion

The feature of isolated protoplasts that has brought them into the limelight is the ability of these naked cells to fuse with each other irrespective of their origin. The technique of hybrid production through the fusion of body cells, bypassing sex altogether, is called somatic hybridization. Unlike sexual reproduction in which organelle genomes are generally contributed by the maternal parent, somatic hybridization also combines cytoplasmic organelles from both the parents. In somatic hybrids, recombination of mitochondrial genome occurs frequently. Chloroplast genome recombination is rare but segregation of chloroplasts of one or the other parent, forming novel nuclear-cytoplasmic combinations. Fusion products with the nucleus of one parent and extra-nuclear genome/s of the other parent are referred to as cybrid and the process to obtain cells or plants with such genetic combination/s are called cybridization.

During enzymatic degradation of cell walls some of the adjacent protoplasts fuse together forming homokaryones (also referred as homokaryotes each with two to several nuclei). This type of protoplast fusion is called as spontaneous fusion. A sequential method of protoplast isolation or exposing the cells to strong plasmolyticum solution before treating them with mixed enzyme solution would affect the plasmodesmatal connection and consequently reduce the frequency of spontaneous fusion. So far as somatic hybridization concerned spontaneous fusion is of no value; these require the fusion of protoplasts of different origin. To achieve induced fusion, a suitable chemical agent (fusogen) or electric stimulus is generally necessary.

Chemical fusion

1. NaNO₃ treatment

Hypotonic solution of NaNO₃ induces the fusion of sub-protoplasts within plasmolysed epidermal cells. However, this technique suffers from a low frequency of heterokaryon formation.

2. High pH and high Ca²⁺ treatment

Mesophyll protoplasts of two different lines of the species could be fused by treating them in a highly alkaline solution (pH 10.5) of high Ca²⁺ ions at 37°C for about 30 min. intra and inter

specific *Nicotiana* hybrids were developed using this technique. However, for some species this high pH may be toxic.

3. Polyethylene glycol (PEG) treatment

PEG has accepted as fusogen because of the reproducible high frequency heterokaryon formation, especially binucleate formation, and its comparatively low cytotoxicity to most cell types. PEG induced fusion is non-specific. In addition to fusing soybean-maize and soybean-barley, PEG brings about effective fusion between animal cells, animal cells with yeast protoplast and animal cells with higher plant protoplasts. The isolated protoplasts of the two selected parents are mixed in appropriate proportions and treated with 15-45% PEG (1500-6000 MW) solution for 15-30 min followed by gradual washing of the protoplasts with the culture medium.

Mechanism of protoplast fusion

Protoplast fusion consists of three main phases:

1. Agglutination, during which the plasma membrane of two or more protoplasts are brought into close proximity.
2. Membrane fusion at small localized regions of close adhesion resulting in the formation of cytoplasmic continuities or bridges between protoplasts.
3. Rounding off of the fused protoplast due to the expansion of the cytoplasmic bridges forming spherical hetero- or homokaryons.

The actual mechanism of PEG-induced fusion is not clear. The accepted hypothesis is that the PEG molecule which is slightly negative in polarity can form hydrogen bonds with water, protein, carbohydrate etc., which possess positively polarized groups. When the PEG molecule chain is large enough it acts as a molecular bridge between the surface of adjacent protoplasts and adhesion occurs. PEG can bind Ca^{2+} as well as other cations. These calcium ions may form a bridge between the negatively polarized groups of protein (or phospholipids) and PEG, thus, enhancing adhesion. During the washing process the PEG molecules bound to the membranes either directly or through Ca^{2+} is eluted, resulting in disturbance and redistribution of the electric charge. Such a redistribution of charge in the regions of intimate contact of the membranes can link some of the positively charged groups of one protoplast to the negatively charged groups of other protoplast and vice versa, resulting in protoplast fusion.

Disadvantages of chemical fusion

1. The fusogens are toxic to some cell types.
2. It produces random, multiple cell aggregates.

Electro fusion of protoplasts

Electro fusion is rapid (usually completes within 15 min), simple, synchronous and more easily controlled. It was shown that electrofusion is more effective than PEG mediated fusion in somatic hybridization of *Solanum tuberosum* and *S. brevidens*. Zimmermann et al., (1982) developed a method, Zimmermann Electrofusion System, which is claimed to be 10000 times better than any other method for protoplast fusion.

This technique utilizes low voltage electric current pulses to align the protoplast in a single row like a pearl-chain. The aligned protoplasts are pushed, with a micromanipulator, at a gentle pace through the narrow gap between the two electrodes. When the two protoplasts that are to be fused are appropriately oriented opposite the electrodes, a short pulse of high voltage is released which induces the protoplasts to fuse. The high voltage creates transient disturbances in the organization of plasmalemma, which leads to the fusion of neighbouring protoplasts. The entire operator is carried out manually in specially devised equipment, called electroporator, under a microscope.

Selection of hybrid cells

The protoplast suspension recovered after a treatment with a fusion-inducing agent consists of the following cell types:

1. Unfused protoplasts of the two parents
2. Products of fusion between two or more protoplasts produced by fusion between the same parents (homokaryon)
3. Hybrid protoplasts produced by fusion between one or more protoplasts of each of the two species (heterokaryon). Heterokaryon particularly those resulting from one protoplast of each of the two parents are of interest; these forms usually in a very small proportion (0.5 –10 %). These hybrid protoplasts are identified by the following strategies.

Visual markers

e. g. pigmentation of the parental protoplasts. The protoplast of one parent may be green and vacuolated (mesophyll cells), while those of the other may be non-vacuolated and nongreen (from cell cultures). If they are not having these features, then these protoplasts are differently labeled with fluorescent dyes. However, this approach is time consuming and requires considerable skill and effort.

Complementation

The property, which is not present in one parent, will be acquired when they are in hybrid state. For example, protoplasts of *Petunia hybrida* form calli on the MS medium, while those of *P. parodii* produce only small cell colonies. Further, actinomycin D inhibits cell division of *P. hybrida* protoplasts, but it has no effect on those of *P. parodii*. Thus protoplasts of both the species fail to produce macroscopic colonies on MS medium supplemented with actinomycin D. However, their hybrid cells (*Petunia hybrida* + *P. parodii*) (note this symbol to denote the somatic hybrids) divide normally on this medium to produce macroscopic colonies. These strategies are simple, highly effective and least demanding. But their applicability is drastically affected by the non availability of suitable properties in most of parental species.

Culture the entire protoplast population

The entire protoplast population is cultured without applying any selection for hybrid cells. All the types of protoplasts form calli; the hybrid calli are later identified on the basis of callus morphology, chromosome constitution, protein and enzyme banding pattern etc.

Cybridization

In sexual hybridization the plastid and mitochondrial genomes are generally contributed by only the female parent whereas in somatic hybridization the extra nuclear genomes from both the parents are combined. Cybrids or cytoplasmic hybrids are cells or plants containing nucleus of one species but cytoplasm from both the parental species. They are produced in variable frequencies in normal protoplast fusion experiments due to one of the following:

- Fusion of a normal protoplast of one species with an enucleate protoplast or a protoplast having an inactivated nucleus of the other species
- Elimination of the nucleus of one species from a normal heterokaryon
- Gradual elimination of the chromosomes of one species from a hybrid cell during the subsequent mitotic divisions.

Cybrids may be produced in relatively high frequency by

- Irradiating (with X or Gamma rays) the protoplasts of one species prior to fusion in order to inactivate their nuclei
- By preparing enucleate protoplasts (cytoplasts) of one species and fusing them with normal protoplasts of the other species.

The objective of the cybrid production is to combine the cytoplasmic genes of one species with the nuclear and cytoplasmic genes of another species. But the mitotic segregation of plasma genes, as evidenced by the distribution of chloroplasts, leads to the recovery of plants having plasma genes of one or the other species only. Only a small proportion of the plants remain cybrid.

This provides the following applications:

- Transfer of plasma genes of one species into the nuclear background of another species in a single generation and even in sexually incompatible species.
- Recovery of recombinants between the parental mitochondria or chloroplast DNAs.
- Production of wide variety of combinations of the parental and recombinant chloroplasts with the parental or recombinant mitochondria.
- Mitochondria from one parental species and chloroplast from another parental species may be combined.

The cybrid approach has been used for the transfer of cytoplasmic male sterility from *Nicotiana tabacum* to *N. sylvestris* and *P. hybrida* to *P. axillaries*.

Advantages of production of CMS lines through cybridization

- Only one step is required.
- The nuclear genotype of cultivar remains unaffected.

100% of the progenies of somatic hybrids will be CMS.

Products of somatic hybrids and cybrids

Chromosome status of somatic hybrids

The chromosome numbers of the somatic hybrids successfully obtained through protoplast fusion indicate that only few have exact number expected in an amphiploid. Hence selection will also need to be applied at the cytological level, if true amphiploids need to be obtained. The variability in chromosome number in hybrids could be due to any one of the following reasons:

- (i) Multiple fusions give a higher chromosome number. In PEG-induced and electro-induced fusions between more than two protoplasts.
- (ii) Asymmetric hybrids result from fusion of protoplasts isolated from actively dividing tissue of one parent and quiescent tissue of the other parent.
- (iii) Unequal rates of DNA replication in two fusing partners may also give asymmetric hybrids.
- (iv) Somaclonal variation in cultured cells used for protoplast isolation may also lead to variation in chromosome number.

Practical applications of somatic hybridisation and cybridisation

1. Means of genetic recombination in asexual or sterile plants

Somatic cell fusion appears to be the only approach through which two different parental genomes can be recombined among plants that cannot reproduce sexually. Further, protoplasts of sexually sterile (haploid, triploid and aneuploid) plants can be fused to produce fertile diploids and polyploids. There are several reports describing the amphidiploid and hexaploid plants produced from fusion of haploid protoplasts of tobacco. Protoplasts isolated from dihaploid potato clones have been fused with isolated protoplasts of *Solanum brevidens* to produce hybrids of practical breeding value. Haploid protoplasts from an anther-derived callus of rice cultivars, upon fusion also produce fertile diploid and triploid hybrids.

2. Overcoming barriers of sexual incompatibility

In plant breeding programmes, sexual crossings at interspecific or intergeneric levels often fail to produce hybrids due to incompatibility barriers. The bottlenecks in sexual hybridisation may therefore, be overcome by somatic cell fusion. In some cases somatic hybrids between two incompatible plants have also found application in industry or agriculture.

Schieder (1978) obtained amphidiploid *Datura innoxia* (+) *D. discolor* and *D. innoxia* (+) *D.*

stramonium, by fusing their diploid mesophyll protoplasts. These hybrids did not exist in nature as conventional breeding procedures proved unsuccessful. Somatically produced amphidiploids of these combinations of *Datura* species are propagated for industrial uses as they demonstrate heterosis and higher (20-25%) scopolamine content than in the parental forms.

Nicotiana repanda, *N. nesophila* and *N. stocktonii* are resistant to a number of diseases but are not sexually crossable with tobacco (*N. tabacum*). However, fertile hybrids have been reported in combination *N. tabacum* (+) *N. nesophila* and *N. tabacum* (+) *N. stocktonii* by protoplast fusion. Somatic hybridisation of dihaploid and tetraploid potato protoplasts with isolated protoplasts of *Solanum brevidens*, *S. phureja* and *S. pennellii* resulted in the synthesis of fertile, partially **amphieuploid** plants possessing important agricultural traits, e.g., resistance to potato leaf virus, potato virus Y and *Erwinia* soft rot. Using this approach, tomato (*Lycopersicon esculentum*) hybridised somatically with a number of wild species has resulted in the synthesis of hybrids which are fertile and used in breeding programmes. Interspecific somatic hybridisation involving species that are sexually incompatible with egg-plant (*Solanum melongena*) has also resulted in the production of amphidiploids with traits resistant to verticillium wilt.

Rapeseed (*Brassica napus*) is a natural amphidiploid of *B. oleracea* and *B. campestris*. Schenk (1982) was the first to resynthesise rapeseed *in vitro* using protoplast fusion. Somatic hybridisation between *B. napus* and *B. nigra* cultivar, possessing the gene for resistance to *Phoma lingam*, yielded amphidiploid plants carrying this gene. These hybrids possess all the three *Brassica* genomes (A, B and C) and are now incorporated in breeding programmes. Recently, hybrids have been produced parasexually by protoplast fusion, between *Brassica juncea* (a major oilseed crop of the tropical world) and the sexually incompatible species *Diploaxis muralis* and *Erica sativa*.

The potential of somatic hybridisation in perennial tree breeding is best illustrated by interspecific and intergeneric somatic hybridisation among citrus species. Somatic hybrids produced through these experiments are amphidiploids featuring characteristics for scion improvement and increased rootstock potential.

Somatic hybrids for cytoplasmic male sterility

Methods were also developed to substitute the nucleus of one species into the cytoplasm of another species, whose mitochondria were inactivated. This type of substitution in some cases, led to generation of cytoplasmic male sterility.

For this purpose, the two types of protoplasts, used for the production of somatic hybrids, were treated differently, as follows:

- (i) mesophyll protoplasts of tomato (*Lycopersicon esculentum*) were treated with iodoacetamide (IOA) to inactivate mitochondria and
- (ii) mesophyll protoplast of *Solanum acaule* (or *S. tuberosum*) were irradiated with gamma-rays to inactivate nuclei.

The protoplasts were mixed in 1:1 ratio and induced to fuse using Ca^{2+} and PEG, leading to the production of heterologous or alloplasmic hybrids. Among the fusion products, some hybrid tomato plants were indistinguishable from the original cultivars, with respect to morphology, physiology and chromosome number ($2n = 24$), but exhibited various degrees of male sterility. In five tomato cultivars, male sterility induced in this manner was inherited maternally over several generations. Therefore, it was obviously cytoplasmic male sterility. The mitochondrial DNA of these CMS hybrids did not resemble mtDNA of either parent, and was instead recombinant type, representing a hybrid mitochondrial genome. Therefore, protoplast fusion can be effectively used for production of CMS lines and has the following advantages:

- (i) Only one step is required;
- (ii) The nuclear genotype of the cultivar remains unaffected,
- (iii) There are prospects that 100% of the progenies of somatic hybrids will be CMS. The restorer lines for these CMS lines have also been shown to be available in tomato, so that hybrid seed can be produced without manual emasculation.

Generation of cytoplasmic male sterility by fusion

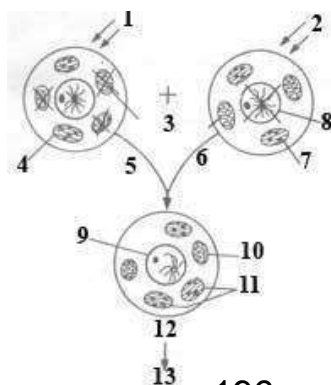

1. IOA (damages mitochondria), 2. γ rays or x-rays (inactivate nuclei), 3. Mitochondria, 4. chloroplast (tomato protoplasts), 5. Ca^{++} PEG, 6. Protoplast fusion, 7. chloroplast (potato or *S. acaule* protoplasts), 8. Nucleus, 9. tomato nucleus, 10. recombinant mitochondria, 11. chloroplasts (mixture), 12. fused protoplasts, 13. somatic hybrid plants (CMS)-resemble tomato

Cytoplasm transfer

Power *et al.* (1975) fused mesophyll protoplasts of *Petunia* with cultured cell protoplasts of the crown gall of *Parthenocissus* and selected a line which contained the chromosomes of only *Parthenocissus* but exhibited some of the cytoplasmic properties of *Petunia* for some time. This was followed by direct application of cybridisation in agricultural biotechnology by transfer of cytoplasmic male sterility from *Nicotiana techne* to *N. tabacum*, *N. tabacum* to *N. sylvestris* and *Petunia hybrida* to *P. axillaris*. Besides cytoplasmic male sterility, the genophore of the cytoplasm codes for a number of practically important traits, such as the rate of photosynthesis, low or high temperature tolerance and resistance to diseases or herbicides. Recent experiments on cybridisation have resulted in plants with reconstructed cytoplasm combining mitochondrial DNA (mt DNA) and cp DNA encoded traits from both parents.

The best example illustrating the potential for protoplast fusion in reconstructing cytoplasm for practical purposes is the genus *Brassica*. Two desirable traits coded by cytoplasmic genes have been genetically manipulated through interspecific cybridisation between different species of *Brassica*. These traits include cytoplasmic male sterility (cms) and resistance to atrazine herbicides. The cms gene in *Brassica* plants, *Diplotaxis muralis* and *Raphanus sativus* is of alloplasmic (the nucleus of one species into a foreign cytoplasm) origin. *Raphanus sativus* is of interest because it leads to complete male sterility. Cms restorer genes have been introduced into rapeseed (*Brassica napus*) from this plant. Mutants resistant to atrazine herbicide have also been discovered both in *Brassica napus* and *B. campestris*. Protoplast fusion experiments (conducted in various laboratories) have resulted in the synthesis of cybrid plants with reconstructed cytoplasm combining both cms (coded by *Raphanus* mt DNA) and low temperature tolerance or atrazine resistance (coded by *Brassica* cp DNA). Similarly, cytoplasmic genes coding for atrazine resistance and cms have been transferred into cabbage, rice and potato.

In somatic hybridisation and cybridisation, the essential pre requisite is that parental protoplasts and their fusion products regenerate to whole plants. Research in the past decade has shown that plants can be raised *in vitro* from isolated protoplasts of species belonging to a range of angiosperm families. Somatic hybrids have been produced between sexually compatible as well as incompatible species. It could be possible to overcome prezygotic embryo/endosperm (*Petunia parodii* (+) *P. inflata*) and postzygotic (*Datura innoxia* (+) *D. stramonium*; *Petunia parodii* (+) *P. parviflora*), incompatibility barriers by protoplast fusion. Experiments on intergeneric somatic hybridisation have also been successful in some cases such as potato (+) tomato somatic hybrids and synthesis of 'Arabidobrassica'. With these initial successes, and subsequent advancements in protoplast technology it is desirable that efforts be concentrated on important plant species which have potential in industry or for food production. Crops which have not yielded satisfactory results through conventional methods of genetic manipulation need to be aided by non-conventional *in vitro* techniques such as somatic hybridisation/cybridisation, embryo culture, etc. to manifest their full potential.

Interspecific hybrids produced through protoplast fusion

Parent species and their chromosome numbers	Chromosome number of hybrid
Brassica oleracea (2n = 18) + B. Campestris (2n = 20)	Wide variation
B. napus (2n = 38) + B. oleracea (2a = 18)	
B. napus (2a = 38) + B. nigra (2n = 16)	
B. napus (2n = 38) + B. carinata (2n = 34)	
B. napus (2n = 38) + B juncea (2n = 36)	
Nicotiana glauca (2n = 24) + N. longsdorfii (2n = 18)	56-64
N. tabacum (2n = 48) + N. alata (2n = 18)	66-71
N. tabacum (2n = 48) + N. glauca (2n = 24)	72
N. tabacum (2n = 48) + N. glutinosa (2n = 24)	50-88
N. tabacum (2n = 48) + N. Knightiana (2n = 24)	44-137
N. tabacum (2n = 48) + N. mesophila (2n = 48)	96
N. tabacum (2n = 48) + N. octophora (2n = 24)	48
N. tabacum (2n = 48) + N. rustica (2n = 48)	60-91
N. tabacum (2n = 48) + N. stocktonii (2n = 48)	96
N. tabacum (2n = 48) + N. sylvestris (2n = 24)	72
N. tabacum (2n = 48) + N. phumbaginifolia (2n = 20)	-

Petunia parodii (2n = -48) + P. hybrida (2n = 20)	44-48
P. parodii (2n = 14) + P. hybrida (2n = 14)	46
P. parodii (2n = 48) + P. parviflora (2n = 18)	31-40
Solanum tuberosum (2n = 24, 48) + S. chapcoense (2n = 14)	60
S. tuberosum (2n = 24, 48) + S. brevidens (2n = 24)	-
Lycopersicon esculentum (2n = 24) + L. Peruvianum (2n = 14)	72
Daucus carota (2n = 18) + D. capillifolius (2n = 18)	36, 38
Datura innoxia (2n = 24) + D. capillifolius (2n = 24)	46, 48, 72
D. innoxia (2n = 24) + D. sanguinea (2n = 24)	46, 72, 96
D. innoxia (2n = 24) + D. candida (2n = 24)	-

Intergeneric hybrids produced through protoplast fusion

Plant species and their chromosome numbers	New genus
Raphanus sativus (2n = 18) + B. oleracea (2n = 18)	Raphanobrassica
Moricandia arvensis (2n = 24, 28) + B. oleracea (2n = 18)	Moricandiobrassica
Eruca sativa (2n = 22) + B. napus (2n = 38)	Erucobrassica
E. sativa (2n = 22) + B. juncea (2n = 36)	Erussica
Diplotaxis muralis (2n = 42) + B. napus (2n = 38)	Diplotaxobrassica
D. muralis (2n = 42) + B. juncea (2n = 36)	Diplotaxojuncea
Sinapis alba (2n = 24) + B. napus (2n = 38)	Sinapobrassica
S. alba (2n = 24) + B. oleracea (2n = 18)	Sinapo-oleracea
Nicotiana tabacum (2n = 24) + Lycopersicon esculentum (2n = 24)	Nicotiopersicon
N. tabacum (2n = 24) + Petunia inflorata (2n = 14)	Nicotiopetunia
Solanum tuberosum (2n = 24) + Lycopersicon esculentum (2n = 24)	Solanopersicon
Daucus carota (2n = 18) + Petroselinum hortense (2n = 22)	Daucoselenium
Datura innoxia (2n = 48) + Atropa belladonna (2n = 24)	Daturotropha
Oryza sativa (2n = 24) + Echinochloa oryzicola (2n = 24)	Oryzochloa

Intertribal somatic hybrids produced within the family Brassicaceae

Arabidopsis thaliana (Tribe Sisymbrieae)	(2n = 10) +	B. Campestris (2n = 20) (Tribe Brassiceae)	Arabidobrassica
Thlaspi perfoliatum (Tribe Lepideae)	(2n = 14) +	B. napus (2n = 38) (Tribe Brassiceae)	Thlaspobrassica
Barbarea vulgaris (Tribe Arabideae)	(2n = 16) +	B. napus (2n = 38) (Tribe Brassiceae)	Barbareobrassica

Even somatic hybrids of sexually compatible plants may exhibit new variations as a result of interactions between plastomes donated by parental species during protoplast fusion. The technique of cybridisation, besides transfer of male sterility, can be adopted for the introduction of genes for resistance into the new species. The modification of plants with respect to nitrogen fixation can also be contemplated through transformation of protoplasts by uptake of exogenous DNA, or organelles, carrying this trait. Further, genetically heterogenous clones can be derived from protoplast culture and fusion which display a high frequency of variations for several agronomic traits.

The above developments suggest an immense potential for somatic cell genetics in crop improvement. However, the genetic diversity that can be generated *via* somatic cell fusion is still poorly understood. This is because only a very limited number of the synthesised somatic hybrids or cybrids have been fertile or amphiploids. Induction and control over the degree of species-specific chromosome elimination in wide or distant somatic hybridisation requires to be mastered in order to understand the mechanism of producing desirable asymmetric nuclear hybrids.

Questions

1. The variability in chromosome number in somatic hybrids could be due to
 - a). Multiple fusions give a higher chromosome number
 - b). Asymmetric hybrids
 - c). Somaclonal variation in cultured cells
 - d). All the above**
2. The somatic hybridisation is used
 - a). Genetic recombination in asexual or sterile plants
 - b). Overcoming barriers of sexual incompatibility
 - c). Both a and b**
 - d). None of the above
3. The first somatic hybrids are produced in
 - a). *Datura innoxia***
 - b). *Nicotiana repanda*
 - c). *N. nesophila*
 - d). *N. stockonii*
4. The first somatic hybrids are produced by
 - a). Schieder**
 - b). Cocking
 - c). Schenk
 - d). None of the above
5. was the first to resynthesise rapeseed *in vitro* using protoplast fusion.
 - a). Schieder
 - b). Cocking
 - c). Schenk**
 - d). None of the above

Genetic engineering in plants

Genetic engineering or recombinant DNA (rDNA) technology involves artificial transfer of genes or gene fragments from one organism to another to produce novel traits in the recipient living organism.

The development of **recombinant DNA technology (rDNA technology)** permitting the transfer of genetic material between widely divergent species has opened a new era of research into the structure and function of the genome. The rDNA technology is defined as "the formation of new combinations of heritable material by the insertion of nucleic acid molecules, produced by whatever means outside the cell, into any virus, bacterial plasmid or other vector system so as to allow their incorporation into a host organism in which they do not naturally occur but in which they are capable of continued propagation. The rDNA technology has provided the means to achieve:

- 1) The fractionation of individual DNA components of complex genomes
- 2) The amplification of cloned genes
- 3) The opportunity to study the expression of individual genes thus cloned and
- 4) The potential to create new genetic combinations

There are several other terms that can be used to describe the technology, including **gene manipulation, gene cloning, genetic modification** and **genetic engineering**. The term genetic engineering is often thought to be rather emotive or trivial, yet it is probably the label that most people would recognize.

Any rDNA experiment has four essential steps:

- 1) Generating DNA fragments
- 2) Cutting and joining the DNA fragments to vector DNA molecules
- 3) Introducing the vectors carrying the foreign DNA into host cells where they can replicate and
- 4) Selecting the clone(s) of recipient cells that have acquired the recombinant DNA molecules

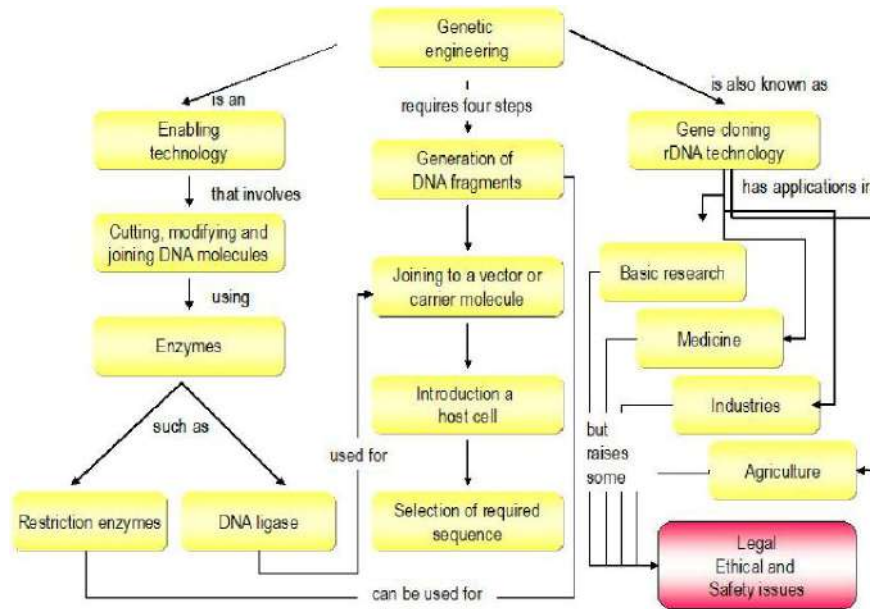

Steps involved in rDNA technology

Generating DNA fragments

One of the most important problems prior to rDNA experiment is to separate the DNA fragments from the total genomic DNA. This is normally accomplished either by fragmentation of DNA or synthesis of new DNA molecule. The fragmentation of DNA molecule can be achieved by mechanical shearing. The long thin threads which constitute duplex DNA molecules are sufficiently rigid to be very easily broken by shear forces in solution. In this method, high molecular weight DNA is sheared to population of molecules with a mean size of about 8kb pairs by stirring at 1500 rpm for 30 minutes. Breakage occurs essentially at random with respect to DNA sequence producing termini consisting of short single stranded regions which may be repaired later. The other sophisticated technique available to generate DNA fragments involves using restriction endonucleases about which discussion is made in the subsequent section. Other two possible sources for generating DNA fragments for cloning are complementary DNA (cDNA) synthesis using mRNA as a template and artificial synthesis of DNA molecule.

cDNA synthesis

Fundamental differences exist between the genomes of prokaryotes and eukaryotes. In prokaryotes, the coding sequences (exons) are not intervened by non-coding sequences (introns) whereas in eukaryotes the genes are generally split; the coding regions are

interspersed with non coding DNA. This makes the expression of eukaryotic genes in prokaryotes a tough task.

Synthesis of cDNA from mRNA

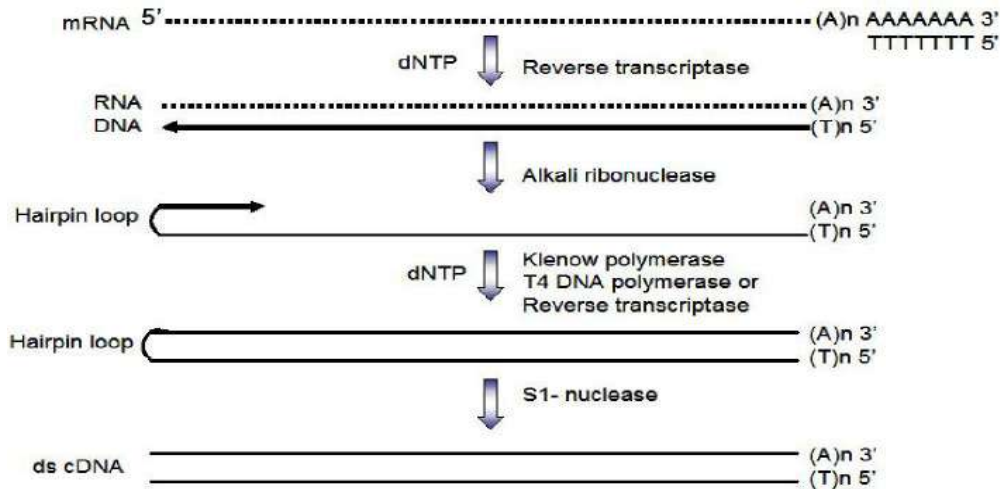

To overcome this problem, cDNA synthesis or artificial DNA synthesis can be well exploited. In cDNA synthesis, the eukaryotic mRNA is used as a template to generate DNA. This can be achieved by making a complementary copy of the mRNA using the enzyme reverse transcriptase and whose function is to synthesize DNA upon an RNA template. At first, the enzyme was called **RNA dependent DNA polymerase**.

A DNA copy is made by hybridizing oligo-T primers, 10 to 20 nucleotides in length, to the 3' end of purified mRNA. Avian myeloblastosis virus (AMV) reverse transcriptase is used to synthesis a cDNA copy of the primed molecule. In the resultant RNA-DNA hybrid, the RNA can be destroyed by alkaline hydrolysis to which DNA is resistant. Thus, a single stranded cDNA is obtained which can be converted into a double stranded form in second DNA polymerase reaction. In the 3' end of the cDNA self-complementary occurs thus producing a hair-pin or snap-back structure. This acts as a primer for duplex DNA synthesis by DNA polymerase. The hair-pin loop is trimmed away by treatment with single strand specific nuclease S1, giving rise to a fully duplex molecule. The power of this technique is that only a fraction of the genome (that fraction which is transcribed into mRNA) is copied. The resulting cDNA clones can be subsequently be used as probes to identify genomic fragments contained in a genomic library.

Chemical synthesis of DNA

Although the methods for generating DNA fragments mentioned above are those most commonly used, the chemical synthesis is considered as an increasingly important method for generating DNA molecules. The chemical synthesis of specific gene sequences, regulatory sequences, oligonucleotide probes, primers and linkers is a technique in which solid phase synthesis is adopted. In chemical synthesis of DNA, two important strategies adopted are described below.

Phosphodiester method

In the phosphodiester method, 3' and 5' hydroxyl groups of deoxyribose are protected (R1 and R2). In this method, the phosphorus group between the two nucleosides is unprotected. These compounds are therefore soluble in organic solvents to a limited extent. The first significant successes, such as the synthesis of the genes for alanine and tyrosine suppressor tRNA for yeast and *E. coli* respectively were gained with the phosphodiester method.

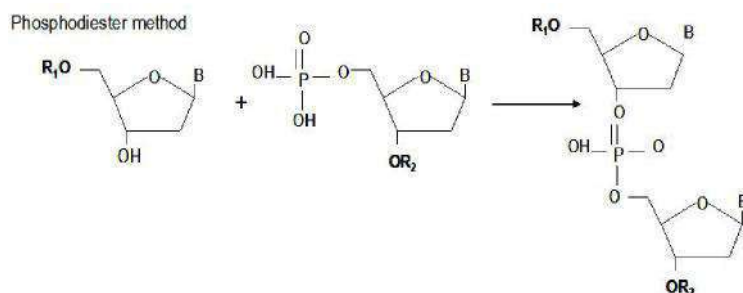

Phosphotriester method

The phosphotriester method for the synthesis of oligodeoxyribonucleotides proceeds essentially in two steps: 1) preparation of suitably protected monomers and 2) coupling of the monomers in the desired sequence by an appropriate phosphorylation procedure.

In both protocols the 3' and 5' hydroxyl groups of the deoxyribose sugar are suitably protected (R1 and R2). In the phosphotriester method a third protecting group (R3) is used for the hydroxyl group at the inter nucleotide bond. Chemical synthesis of DNA has found an extraordinary number of applications in gene technology which include synthesis of partial or total gene sequences, primers for DNA and RNA sequencing, hybridization probes for the screening of RNA, DNA and cDNA or genomic libraries and adapters and linkers for gene cloning

Cutting and joining the DNA fragments to vector DNA molecules

Restriction endonucleases: Tool for cutting DNA molecules

Techniques for cutting of DNA molecules into discrete fragments by specific enzymes were virtually unknown until the late sixties. A solution to this fundamental problem eventually grew from long standing research into the phenomenon of **host controlled restriction and modification system**.

Host controlled restriction and modification phenomenon can be well explained with the following example. If a stock preparation of phage is allowed to grow upon *E. coli* strain C and this stock is then tried upon *E. coli* C and *E. coli* K, the titres observed on these two strains will differ by several orders of magnitude, the titre on *E. coli* K being the lowest. The phages are said to be restricted by the second host strain (*E. coli* K) and the phenomenon is called **restriction**. When those phage that do result from the infection of *E. coli* K are now replated on *E. coli* K they are no longer restricted; but if they are first cycled through *E. coli* C they are once again restricted when plated upon *E. coli* K. The non-heritable change conferred upon the phage by the second host strain (*E. coli* K) that allows it to be replicated on that strain without further restriction is called **modification**. These processes can occur whenever DNA is transferred from one bacterial strain to another. Conjugation, transduction, transformation and transfection are all subject to the constraint of host controlled restriction and this process is made possible by the enzymes called **restriction endonucleases**.

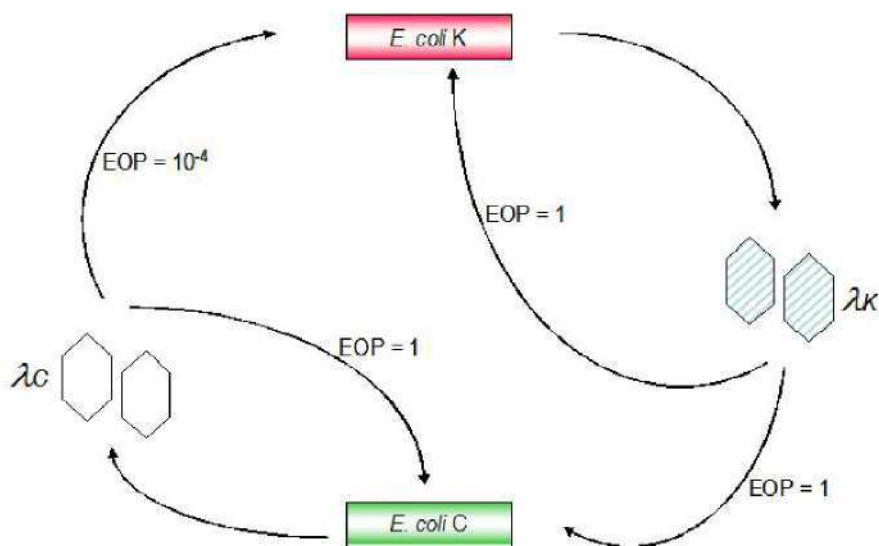

Ligases: Tool for joining DNA fragments

Joining DNA fragments of various types is yet another fundamental step in rDNA technology. This process is otherwise called as ligation and is achieved by the catalytic reaction of enzymes called ligases. These enzymes catalyses the formation of phosphodiester bonds between DNA molecules. The ligase enzymes of *E. coli* and phage T4 have the ability to seal the single stranded nicks between nucleotides in a duplex DNA.

Ligation

Although the reactions catalyzed by the enzymes of *E. coli* and T4 infected *E. coli* are similar, they differ in their cofactor requirements. The T4 enzyme requires ATP, while the *E. coli* enzymes require NAD⁺. In each case the cofactor is split to form an **enzyme-AMP complex**. The complex binds to the nick, which must expose a 5'- phosphate and 3'-OH group, and makes a covalent bond in the phosphodiester chain.

The other enzyme having utility in ligation is terminal deoxynucleotidyl- transferase. This adds an entire nucleotide to 3' end of the chain. It requires a source of energized nucleotides and simply adds them to the growing chain. This means that, if some DNA is mixed with terminal transferase and just one nucleotide, say the adenine nucleotide, the chain will grow as succession of adenines at the 3' end of the strand. If another chain is incubated with terminal transferase and thymine nucleotides it will have a protruding strand that is all thymine. If the above two strands are mixed together the complementary base pairing between the protruding strands will give duplex DNA.

Prevention of self-ligation

In rDNA technology, prevention of self-ligation in vector DNA molecules or passenger DNA molecules is considered more important. Generally vector DNA molecules are highly susceptible to self ligation thus forming recircularised DNA molecules. The presence of self ligated molecules reduces the probability of recovering desired recombinant clones. Self ligation can be reduced to some extent by adopting homo polymer tailing. Wherever homopolymer tailing is undesirable other strategies like directional cloning and dephosphorylation of termini can be followed.

Directional cloning: Directional cloning is otherwise called forced cloning. This is possible in a vector having two or more target sites in a non essential portion of the

DNA. Cleavage at these sites cause the removal of non essential DNA and produce a vector molecule with two different termini which are not complementary so that the individual vectors cannot recircularise.

Dephosphorylation of termini: The main function of DNA ligase is to produce a phosphodiester bond between adjacent nucleotides if one contains a 5' PO₄ group and the other a 3' –OH group. Thus, removal of terminal 5' PO₄ groups from the cleaved DNA will prevent self ligation. Dephosphorylation of termini can be carried out by treating linearised DNA with bacterial alkaline phosphatase. The dephosphorylated DNA molecules can be religated with phosphorylated passenger DNA to produce functional recombinant DNA molecules.

rDNA techniques for the production of transgenic

Genetic engineering or recombinant DNA (rDNA) technology involves artificial transfer of genes or gene fragments from one organism to another to produce novel traits in the recipient living organism. The important tools used in rDNA technology include:

Enzymes for DNA manipulation

The first step in the construction of a recombinant DNA molecule, involves cleaving DNA molecules at specific points and recombining them together again in a controlled manner. The two main types of enzymes commonly used for this purpose are restriction endonucleases and DNA ligases. These enzymes form the backbone of rDNA technology. Restriction endonucleases cut DNA into defined fragments by targeting junction of specific sequences of the genetic coding and DNA ligases recombine them by consolidating loose bonds for creating large fragments. These enzymes are very specific in their action.

Vectors

The function of the vector is to enable the foreign genes to get introduced into and become established within the host cell. Naturally occurring DNA molecules that satisfy the basic requirements for a vector are plasmids and the genomes of bacteriophages and eukaryotic viruses. They are further classified as cloning and expression vectors depending on the stage of genetic engineering at which these vectors are used.

Expression hosts

The functional cell into which the composite DNA molecule carrying the required gene needs to be introduced is called the expression host. The choice of the best host-vector system for the expression and large-scale production of a particular protein is based on considerations of the complexity of the protein to be expressed and the yield and quantities needed.

Marker genes

Marker genes and reporter genes are utilized for selection and identification of the clones. These use phenotypic markers, identification from a gene library and DNA sequencing. DNA sequencing helps in determining the precise order of nucleotides in a piece of DNA.

Construction and Identification of recombinant DNA molecules

Recombinant DNA (rDNA) has various definitions, ranging from very simple to strangely complex. The following are three examples of how recombinant DNA is defined:

1. A DNA molecule containing DNA originating from two or more sources.
2. DNA that has been artificially created. It is DNA from two or more sources that is incorporated into a single recombinant molecule.
3. According to the NIH guidelines, recombinant DNA are molecules constructed outside of living cells by joining natural or synthetic DNA segments to DNA molecules that can replicate in a living cell, or molecules that result from their replication.

Description of rDNA

Recombinant DNA, also known as *in vitro* recombination, is a technique involved in creating and purifying desired genes. Molecular cloning (i.e. gene cloning) involves creating recombinant DNA and introducing it into a host cell to be replicated. One of the basic strategies of molecular cloning is to move desired genes from a large, complex genome to a small, simple one. The process of *in vitro* recombination makes it possible to cut different strands of DNA, *in vitro* (outside the cell), with a restriction enzyme and join the DNA molecules together via complementary base pairing.

Techniques

Some of the molecular biology techniques utilized during recombinant DNA include:

1. **The study and/or modification of gene expression patterns**
Gene expression is the process by which a gene's coded information is converted into the structures present and operating in the cell. Expressed genes include those that are transcribed into mRNA (messenger RNA) and then translated into protein, and those that are transcribed into tRNA (transfer RNA) and rRNA (ribosomal RNA). Gene expression can be studied using microarray analysis, which is a method of visualizing the patterns of gene expression of thousands of genes using fluorescence or radioactive hybridization.
2. **Gene cloning:** Gene cloning utilizing recombinant DNA technology is the process of manipulating DNA to produce multiple copies of a single gene or segment of DNA.
3. **DNA sequencing**
DNA sequencing is a lab technique used to determine the sequence of nucleotide bases in a molecule of DNA.
4. **Creation of transgenic plants and animals**
A transgenic plant or animal is one who has been genetically engineered, and usually contains genetic material from at least one unrelated organism, such as from a virus, other plant, or other animal.

Processes

The following is a summary of the process of making recombinant DNA:

1. Treat the DNA taken from both sources with the same restriction endonuclease.
2. The restriction enzyme cuts both molecules at the same site.
3. The ends of the cut have an overhanging piece of single-stranded DNA called "sticky ends."
4. These sticky ends are able to base pair with any DNA molecule that contains the complementary sticky end.
5. Complementary sticky ends can pair with each other when mixed.
6. DNA ligase is used to covalently link the two strands into a molecule of recombinant DNA.
7. In order to be useful, the recombinant DNA needs to be replicated many times (i.e. cloned). Cloning can be done *in vitro*, via the Polymerase Chain

Reaction (PCR), or *in vivo* (inside the cell) using unicellular prokaryotes (e.g. *E. coli*), unicellular eukaryotes (e.g. yeast), or mammalian tissue culture cells.

Figure . A pictorial representation of the recombinant DNA process.

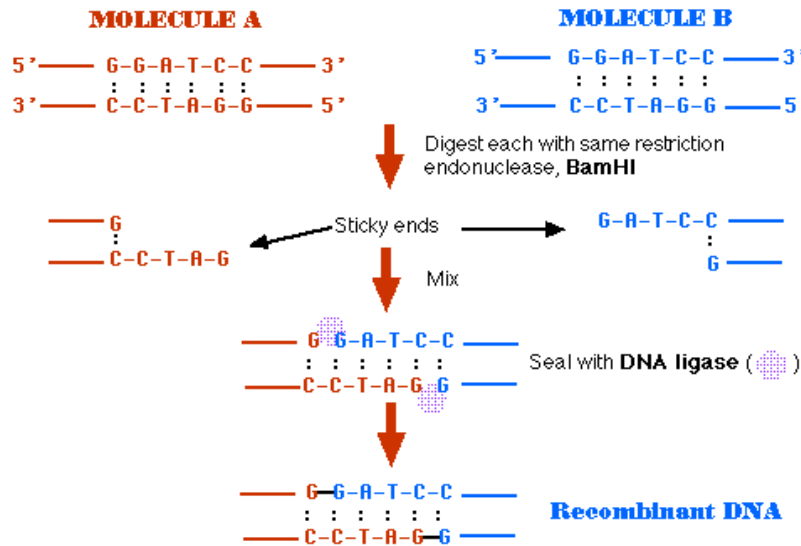

Generating DNA fragments using restriction endonucleases

Restriction endonucleases are enzymes that recognize specific sequences within duplex DNA molecules and cut the DNA at or near these sites. More than 500 different restriction endonucleases have been discovered. These enzymes can be grouped into three types *viz.* Type I, II and III. For practical purposes, the Type I and III restriction enzymes are not much used in rDNA technology. The real precision scissors are the Type II enzymes. Type II restriction endonucleases recognize and cut DNA within particular sequences of tetra, penta, hexa or hepta nucleotides which have an axis of rotational symmetry. In the following examples, different restriction enzymes cut the DNA at specific sequences as indicated by arrows.

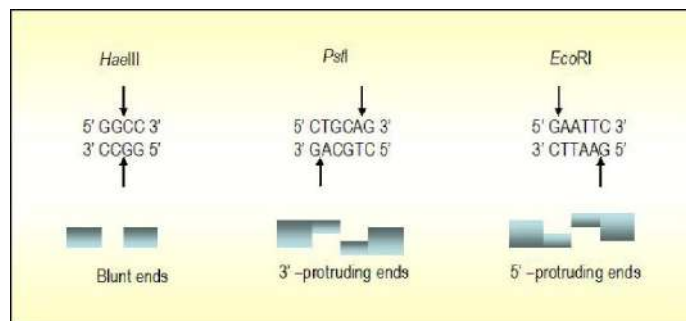

Among the restriction enzymes, some enzymes cut the DNA molecules to give **blunt end** fragments otherwise termed as **flush end** DNA fragments and some others produce DNA molecules where one of the strands will have protruding 5' or 3' termini. These

fragments are called fragments with **cohesive ends** or **sticky ends**. The majority of the recognition sequences for restriction endonucleases are **palindromic**, that is the sequence is the same if read from 5' to 3' from both complementary strands.

The sites of cut made by endonucleases are called **target sites** or **cleavage sites** and the number of these sites in a DNA molecule depends on the size of the DNA, its base composition and the GC content of the recognition site. The number and size of the fragments generated by a restriction enzyme depends on the frequency of occurrence of the target site in the DNA to be cut. Assuming a DNA molecule with a 50 percent G+C content and a random distribution of four bases, a restriction enzyme recognizing a particular tetranucleotide sequence will be able to cut the DNA molecules into fragments at once in every 44 (*i.e.* 256) nucleotide pairs. If the enzyme is having the property of making cuts in hexanucleotide sequences means, the cuts will be made at every 46 (*i.e.* 4096) nucleotide pairs and an eight nucleotide recognition sequence 48 (65536) base pairs.

Restriction enzymes that have the same recognition sequences can be isolated from different bacterial species. Such enzymes are called **isoschizomers**. An example is provided by **Mbol** (*Moraxella boris*) and **Sau3A** (*Staph yhcoccus aureus*), both of which recognize the sequence **GATC**. Furthermore, some restriction enzymes generate cohesive ends that can reanneal with identical termini produced by other enzymes. For instance, DNA cleaved with *Bam*HI (GGATCC) has compatible ends with DNA cleaved with *Bg*II, *Mbol*, *Sau3A*, *etc.*

The number of restriction fragments made by an enzyme would be reduced if there is a methylation of restriction sites. In some cases, the DNA recognition by an enzyme will not be altered by methylation and enzymes of this nature are said to be **enzymes with star activity** *e.g.* *Eco*RI, *Bam*HI and *Sal*I.

Ligation strategies

In rDNA technology, sealing discontinuities in the sugar-phosphate chains, otherwise called as ligation, is vital step. This process is catalyzed by DNA ligase by repairing broken phosphodiester bonds. During ligation, the enzyme's activity is influenced by factors such as 1) substrate specificity, 2) temperature and 3) salt concentration

Ligation methods

Joining DNA fragments with cohesive ends by DNA ligase is a relatively efficient process, which has been extensively used to create artificial recombinants. If the termini of DNA fragments are not compatible, there are other methods to ligate the fragments.

Cohesive end ligation

The cohesive end ligation is possible when both the foreign DNA to be cloned and the vector DNA possess the same molecular ends. The compatible sticky ends have been generated by cleavage with the same enzyme on the same recognition sequences of both foreign DNA and vector DNA. Using DNA ligase, these molecules can be ligated without any problem.

Very often it is necessary to ligate DNA fragments with different and non-compatible ends, or blunt ends with either staggered 3' or 5' ends. Incompatible DNA fragments with recessed ends can be ligated by modifying their ends by any one of the following methods *viz.*, (i) filling in recessed 3' termini and (ii) renewal of 5' protruding termini.

Blunt end ligation

The *E. coli* DNA ligase will not catalyze blunt end ligation except under special reaction conditions of macromolecular crowding. The unique property of T4 DNA ligase was used to ligate DNA fragments with blunt ends involving short decameric oligonucleotides called **linkers**.

Using linkers

Short oligonucleotides (decamers) which contain sites for one or more restriction enzymes are used to facilitate the ligation process among the DNA fragments with blunt ends.

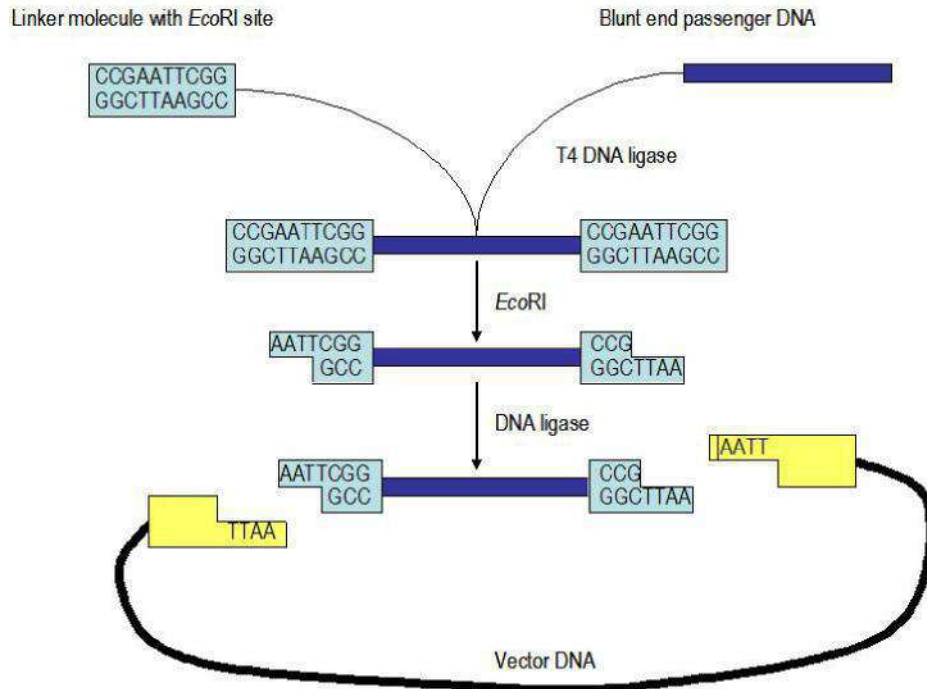

Joining of blunt end DNA to a vector using linkers

The linker molecules can be ligated to both ends of the foreign DNA to be cloned and then treated with restriction endonuclease to produce sticky end fragments which can be incorporated into a vector molecule that has been cut with the same restriction endonuclease. Insertion by means of the linker creates restriction sites at each end of the foreign DNA, and thus enables the foreign DNA excised and recovered after cloning and amplification in the host bacterium.

Using adaptors

The other strategy adopted for ligating DNA fragments with blunt ends is using **adaptors**. The adaptor molecules are synthetic deoxynucleotides that can be used to join two incompatible cohesive ends, two blunt ends or a combination of both. Such adaptors are of several types *viz.*, **preformed**, **conversion** and **single stranded adaptors**.

Preformed adaptors

Preformed adaptors are short DNA duplexes with at least one cohesive end. The problem of internal cleavage of the insert DNA can be overcome by using a preformed adaptor that will introduce a new restriction site. For example, an adaptor having *Bam*HI cohesive ends and sites *Hpa*II and *Sma*I can be attached to passenger DNA and

inserted into a *Bam*HI in vector. After cloning, passenger DNA can be excised from the hybrid by using any one of the enzymes that recognize the restriction sites within the adaptor region.

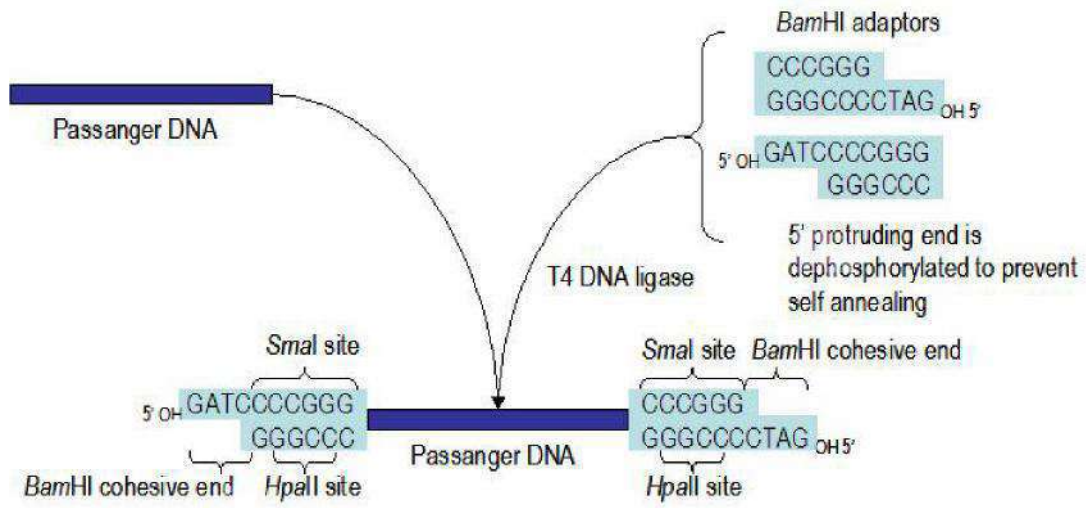

Use of preformed adaptors

Conversion adaptors

Conversion adaptors are synthetic oligonucleotides bearing different cohesive restriction termini. Such adaptors enable vector molecules that have been cleaved with one endonuclease to be joined to passenger fragments that have been cleaved with another. Often these adaptors contain internal restriction sites that permit recovery of the passenger fragment, for example, the *Eco*RI-*Bam*HI adaptor contains a site for *Xho*I.

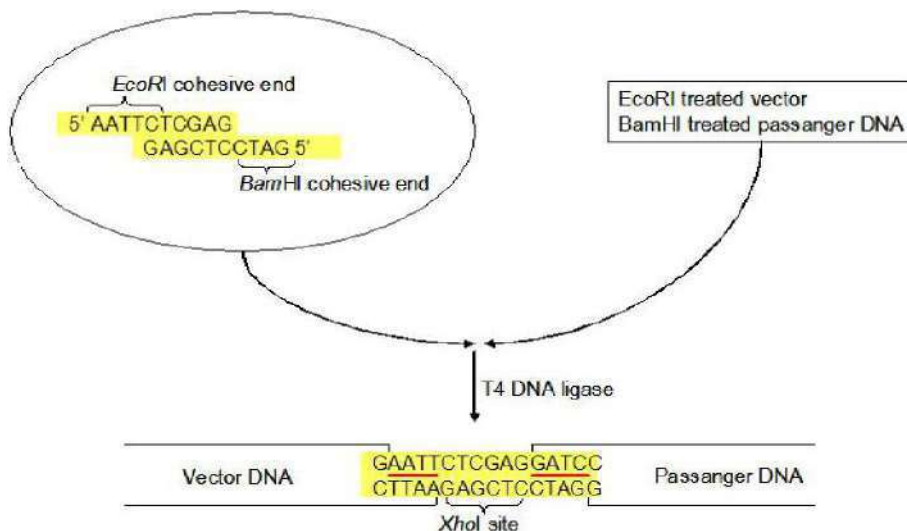

Use of conversion adaptor

Single stranded adaptors

Single stranded adaptors can be used to make 3'-protruding cohesive ends compatible with 5' protruding ends. Such adaptors permit the insertion of passenger fragments into sites on vectors from which they would otherwise be precluded because of incompatible cohesive ends.

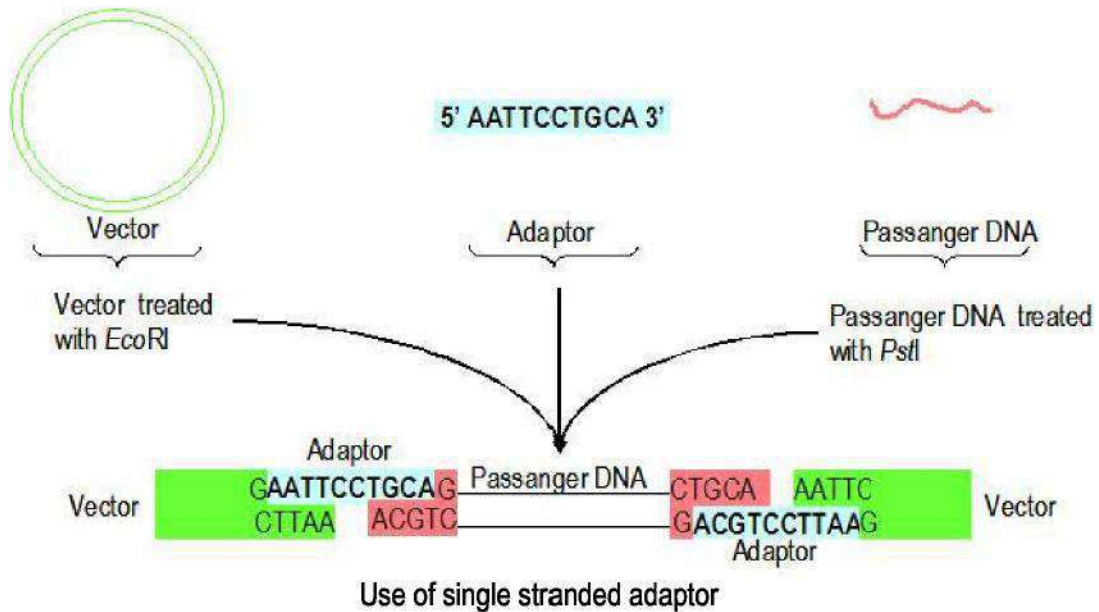

Homopolymer tailing

Homopolymer tailing is the other method adopted to clone blunt DNA molecules, especially cDNA molecules.

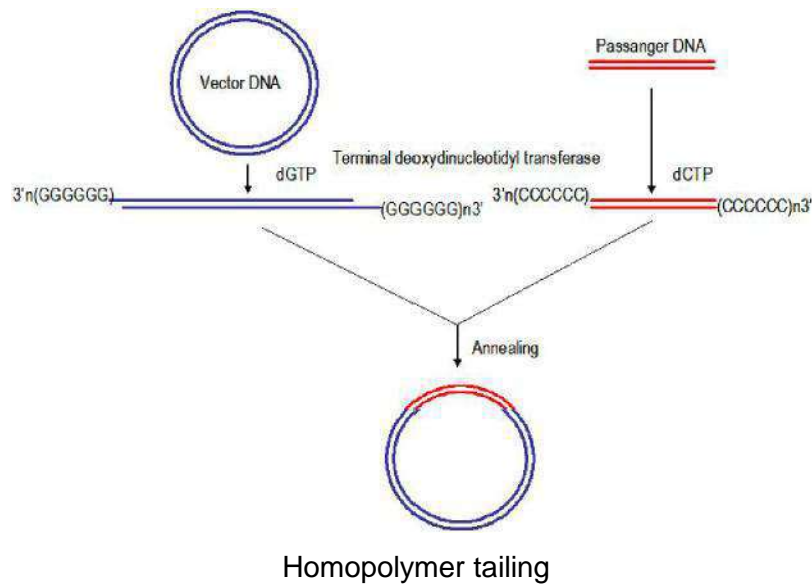

The addition of several nucleotides of single type to the 3' blunt end of DNA molecule is catalyzed by the enzyme **terminal deoxynucleotidyl transferase**. The terminal transferase permits the addition of complementary homopolymer tails (50 to 150 dA or dT long and about 20 dG or dC long) to 3' end of plasmid vector and passenger DNA. These tails can reanneal to form open circular hybrid molecules, which can be ligated *in vitro* or more commonly *in vivo* following transformations to produce functional recombinant molecules.

Selection of recombinants

Making recombinant molecules is a game with very long odds against success. Even when the bits of DNA have been joined up and inserted into cells, only very few cells out of many tens of thousands will contain the recombinant molecule and all the technical expertise in the world is no use whatsoever unless one can find the cell that contain the recombinant DNA. Techniques for selecting the few valuable cells from the mass of useless ones are thus of paramount importance.

Directional selection

The phenotypes conferred by the cloned genes on the host are used as markers of selection. All useful vector molecules carry a selectable genetic marker or have a genetically selectable property. Plasmid vectors generally possess drug resistance or nutritional markers and in phage vectors the plaque formation itself is the selectable property.

Insertional inactivation

The technique depends upon homologous recombination between DNA cloned and the host genome. If the cloned sequence lacks both promoter and sequences encoding essential regions of the carboxyl terminus of the protein, recombination with homologous genomic sequences will cause gene disruption and produce a mutant genotype. On the other hand, if the cloned fragment contains appropriate transcriptional and translational signals, homologous recombination will result in synthesis of a functional mRNA transcript, and no mutant phenotype will be observed.

Questions

1. The rDNA technology has provided the means to achieve
 - a). Amplification of cloned genes
 - b). Fractionation of individual DNA components of complex genomes
 - c). Potential to create new genetic combinations
 - d). All the above**
2. The other terms that can be used to describe rDNA technology
 - a). Gene manipulation
 - b). Gene cloning
 - c). Genetic modification
 - d). All the above**
3. The essential steps in rDNA technology is
 - a). 4**
 - b). 5
 - c). 2
 - d). 7
4. In cDNA synthesis, the eukaryotic is used as a template to generate DNA.
 - a). mRNA**
 - b). tRNA
 - c). rRNA
 - d). None of the above
5. The enzyme reverse transcriptase is also called as
 - a). RNA dependent DNA polymerase**
 - b). DNA dependent DNA polymerase
 - c). RNA dependent RNA polymerase
 - d). None of the above
6. The chemical synthesis of DNA is by
 - a). Phosphodiester method
 - b). Phosphotriester method
 - c). Both a and b**
 - d). None of the above
7. The tool for cutting DNA molecules is/are
 - a). Restriction endonucleases**
 - b). Ligases
 - c). Both a and b
 - d). None of the above
8. The tool for joining DNA molecules is/are
 - a). Restriction endonucleases
 - b). Ligases**
 - c). Both a and b
 - d). None of the above
9. The important tools used in rDNA technology include
 - a). Enzymes for DNA manipulation
 - b). Vectors
 - c). Expression hosts
 - d). All the above**

10. The rDNA technology is used for

- a). Gene cloning
- b). DNA sequencing
- c). Creation of transgenic plants and animals
- d). All the above**

11. The restriction enzymes are grouped into types

- a). 3**
- b). 5
- c). 2
- d). None of the above

12. The restriction enzymes used abundantly in rDNA technology is

- a). Type I
- b). Type II**
- c). Type III
- d). None of the above

13. The restriction enzyme with star activity is/are

- a). *EcoRI*
- b). *BamHI*
- c). *SaI*
- d). All the above**

Enzymes used in Genetic Engineering

The ability to manipulate DNA *in vitro* depends entirely on the availability of purified enzymes that can cleave, modify and join the DNA molecule in specific ways.

At present, no chemical method can achieve the ability to manipulate the DNA *in vitro* in a predictable way. Only enzymes are able to carry out the function of manipulating the DNA. Each enzyme has a vital role to play in the process of genetic engineering. The various enzymes used in genetic engineering are as follows:

- ❖ Nucleases
- ❖ Restriction enzymes
- ❖ DNA ligase
- ❖ Kinase
- ❖ Phosphatase
- ❖ Reverse transcriptase
- ❖ Terminal Deoxynucleotide Transferase
- ❖ RNaseP

The functions of the various enzymes used in genetic engineering are depicted below:

Nucleases - Nucleases are a group of enzymes which cleave or cut the genetic material (DNA or RNA).

DNase and RNase

Nucleases are further classified into two types based upon the substrate on which they act. Nucleases which act on or cut the DNA are classified as DNases, whereas those which act on the RNA are called as RNases.

DNases are further classified into two types based upon the position where they act. DNases that act on the ends or terminal regions of DNA are called as exonucleases and those that act at a non-specific region in the centre of the DNA are called as endonucleases.

Exonucleases require a DNA strand with at least two 5 and 3 ends. They cannot act on DNA which is circular. Endonucleases can act on circular DNA and do not require any

free DNA ends (*i.e.*, 5 or 3 end). Exonucleases release nucleotides (Nucleic acid + sugar + phosphate), whereas endonucleases release short segments of DNA.

Restriction Enzymes

DNases which act on specific positions or sequences on the DNA are called as restriction endonucleases. The sequences which are recognized by the restriction endonucleases or restriction enzymes (RE) are called as recognition sequences or restriction sites. These sequences are palindromic sequences. Different restriction enzymes present in different bacteria can recognize different or same restriction sites. But they will cut at two different points within the restriction site. Such restriction enzymes are called as isoschizomers. Interestingly no two restriction enzymes from a single bacterium will cut at the same restriction site.

Mode of action

The restriction enzyme binds to the recognition site and checks for the methylation (presence of methyl group on the DNA at a specific nucleotide). If there is methylation in the recognition sequence, then, it just falls off the DNA and does not cut. If only one strand in the DNA molecule is methylated in the recognition sequence and the other strand is not methylated, then RE (only type I and type III) will methylate the other strand at the required position. The methyl group is taken by the RE from S-adenosyl methionine by using modification site present in the restriction enzymes.

However, type II restriction enzymes take the help of another enzyme called methylase, and methylate the DNA. Then RE clears the DNA. If there is no methylation on both the strands of DNA, then RE cleaves the DNA.

It is only by this methylation mechanism that, RE, although present in bacteria, does not cleave the bacterial DNA but cleaves the foreign DNA. But there are some restriction enzymes which function exactly in reverse mode. They cut the DNA if it is a methylate.

Star activity

Sometimes restriction enzymes recognize and cleave the DNA strand at the recognition site with asymmetrical palindromic sequence, for example Bam HI cuts at the sequence GA TCC, but under extreme conditions such as low ionic strength it will cleave in any of the following sequence NGA TCC, GPOA TCC, GGNTCC. Such an activity of the RE is

called star activity.

Nomenclature of Restriction Enzymes

As a large number of restriction enzymes have been discovered, a uniform nomenclature system is adopted to avoid confusion. This nomenclature was first proposed by Smith and Nattens in 1973.

Every restriction enzyme would have a specific name which would identify it uniquely. The first three letters, in italics, indicate the biological source of the enzymes, the first letter being the initial of the genus and the second and third being the first two letters of the species name. Thus restriction enzymes from *Escherichia coli* are called *Eco*; *Haemophilus influenzae* becomes *Hin*; *Diplococcus pneumoniae* *Dpn* and so on. Then comes a letter that identifies the strain of bacteria; *Eco R* for strain R. Finally there is a roman numeral for the particular enzyme if there are more than one in the strain in question; *Eco RI* for the first enzyme from *E. coli* R, *Eco RII* for the second.

Types

The restriction endonucleases can be divided into three groups as type I, II and III. Types I and III have an ATP dependent restriction activity and a modification activity resident in the same multimeric protein. Both these types recognize unmethylated recognition sequences in DNA. Type I enzymes cleave the DNA at random site, whereas Type III cleave at a specific site. Type II restriction modification system possess separate enzymes for endonuclease and methylase activity and are the most widely used for genetic manipulation.

Type I Restriction Enzymes

These restriction enzymes recognize the recognition site, but cleave the DNA somewhere between 400 base pairs (bp) to 10,000 bp or 10 kbp right or left. The cleavage site is not specific. These enzymes are made up of three peptides with multiple functions. These enzymes require Mg⁺⁺, ATP and S adenosyl methionine for cleavage or for enzymatic hydrolysis of DNA. These enzymes are studied for general interest rather than as useful tools for genetic engineering.

Type II Restriction Enzymes

Restriction enzymes of this type recognize the restriction site and cleave the DNA within

the recognition site or sequence. These enzymes require Mg⁺⁺ as cofactor for cleavage activity and can generate 5'-PO₄ or 3'-OH. Enzymes of this type are highly important because of their specificity. Type II restriction enzymes are further divided into two types based upon their mode of cutting.

Type II Restriction Enzymes - Blunt End Cutters

Blunt end cutters Type II restriction enzymes of this class cut the DNA strands at same points on both the strands of DNA within the recognition sequence. The DNA strands generated are completely base paired. Such fragments are called as blunt ended or flush ended fragments.

Type II Restriction Enzymes - Cohesive End Cutters

Cohesive end cutter Type II restriction enzymes of this class cut the DNA stands at different points on both the strands of DNA within the recognition sequence. They generate a short single-stranded sequence at the end. This short single strand sequence is called as sticky or cohesive end. This cohesive end may contain 5'-PO₄ or 3'-OH, based upon the terminal molecule (5'-PO₄ or 3'-OH). These enzymes are further classified as 5' end cutter (if 5'-PO₄ is present) or 3' end cutter (if 3'-OH is present).

Type III Restriction Enzymes

Type III Restriction enzymes of this type recognize the recognition site, but cut the DNA 1 kbp away from the restriction site. These enzymes are made up of two peptides or subunits. These enzymes require ATP, Mg⁺⁺ and S-adenosyl methionine for action.

The properties of three types of restriction endonucleases and a list of enzymes are given below.

Property	Type I	Type II	Type III
Structure	Enzyme complex of 500-600 k dal composed of three separate subunits	Normally homodimers of 20-70 k dal	Heterodimers with subunits of 70 and 100 k dal
Composition	Multienzyme complex with R (endonuclease), M (methylase) and S (specificity) subunits	Separate enzymes; endonuclease is a monomer	M subunit provides specificity on its own; functions as methylase; as heterodimer with R subunit; functions as methylase-endonuclease

Cofactors	Mg ²⁺ , ATP, S-adenosylmethionine (SAM) (needed for cleavage as well as methylation)	Mg ²⁺ , SAM (for methylation only)	Mg ²⁺ , ATP (for cleavage), SAM (needed for methylation: stimulate cleavage)
Recognition sites	Asymmetric, bipartite, may be degenerate; 13-15 base pairs containing interruption of 6 to 8 base pairs	Asymmetric, may be bipartite, may be degenerate; 4 to 8 base pairs normally 180° rotational symmetry	Asymmetric, uninterrupted, 5-6 nucleotide long with no rotational symmetry
Cleavage	Non-specific, variable distance (100-1000 nucleotides) from recognition site	Precise cleavage within recognition site at defined distance	Precise cleavage at a fixed distance; 25-27 nucleotides from recognition site
Example	<i>EcoK</i>	<i>EcoRI</i>	<i>EcoP1</i>

Some restriction endonucleases and their recognition sites

Enzyme	Recognition site	Enzyme	Recognition site
4-base cutters		6-base cutters	
<i>Mbol</i> , <i>Dpnl</i> , <i>Sau3AI</i>	/GATC	<i>BglI</i>	A/GATCT
<i>Mspl</i> , <i>HpaII</i>	C/CGG	<i>ClaI</i>	AT/CGAT
<i>AluI</i>	AG/CT	<i>PvuII</i>	CAG/CTG
<i>HaeIII</i>	GG/CC	<i>PvuI</i>	CGAT/CG
<i>Tal</i>	AC/GT	8-base cutters	
		<i>NotI</i>	GC/GGCCCC
		<i>SbfI</i>	CCTGCA/GG

DNA Ligase

Recombinant DNA experiments require the joining of two different DNA segments or fragments *in vitro*. The cohesive ends generated by some RE will anneal themselves by forming hydrogen bonds. But the segments annealed thus are weak and do not withstand experimental conditions. To get a stable joining, the DNA should be joined by using an enzyme called ligase. DNA ligase joins the DNA molecule covalently by catalysing the formation of phosphodiester bonds between adjacent nucleotides.

DNA ligase isolated from *E. coli* and T 4 bacteriophage is widely used. These ligases more or less catalyse the reaction in the same way and differ only in requirements of cofactor. T4 ligase requires ATP as cofactor and *E. coli* ligase requires NADP as

cofactor. The cofactor is first split (ATP - AMP + 2Pi) and then AMP binds to the enzyme to form the enzyme-AMP complex. This complex then binds to the nick or breaks (with 5' -PO₄ and 3' -OH) and makes a covalent bond in the phosphodiester chain. The ligase reaction is carried out at 4°C for better results.

Kinase

Kinase is the group of enzymes, which adds a free pyrophosphate (PO₄) to a wide variety of substrates like proteins, DNA and RNA. It uses ATP as cofactor and adds a phosphate by breaking the ATP into ADP and pyrophosphate. It is widely used in molecular biology and genetic engineering to add radiolabelled phosphates.

Alkaline phosphatases

Phosphatases are a group of enzymes which remove a phosphate from a variety of substrates like DNA, RNA and proteins. Phosphatases which act in basic buffers with pH 8 or 9 are called as alkaline phosphatases. Most commonly bacterial alkaline phosphatases (BAP), calf intestine alkaline phosphatases (CIAP) and shrimp alkaline phosphatases are used in molecular cloning experiments. The PO₄ from the substrate is removed by forming phosphorylated serine intermediate. Alkaline phosphatase is metalloenzymes and has Zn⁺⁺ ions in them.

BAP (bacterial alkaline phosphatase) is a dimer containing six Zn⁺⁺ ions, two of which are essential for enzymatic activity. BAP is very stable and is not inactivated by heat and detergent.

Calf intestine alkaline phosphatase (CIAP) is also a dimer. It requires Zn⁺⁺ and Mg⁺⁺ ions for action. CIAP is inactivated by heating at 70°C for twenty minutes or in the presence of 10 mM EGTA. Alkaline phosphatases are used to remove the PO₄ from the DNA or as reporter enzymes.

Reverse Transcriptase

This enzyme uses an RNA molecule as template and synthesizes a DNA strand complementary to the RNA molecule. These enzymes are used to synthesize the DNA from RNA. These enzymes are present in most of the RNA tumour viruses and retroviruses. Reverse transcriptase enzyme is also called as RNA dependent DNA polymerase. Reverse transcriptase enzyme, after synthesizing the complementary

strand at the 3' end of the DNA strand, adds a small extra nucleotide stretch without complementary sequence. This short stretch is called as R-loop.

Terminal Deoxynucleotide transferase

Terminal deoxynucleotide transferase is a polymerase which adds nucleotides at 3' -OH end (like Klenow fragment) but does not require any complementary sequence and does not copy any DNA sequence (unlike Klenow fragment). Terminal deoxynucleotide transferase (TDNT) adds nucleotide whatever comes into its active site and it does not show any preference for any nucleotide.

RNase P

It specifically cleaves at the 5' end of RNA. It is a complex enzyme consisting of small protein (20 kilodaltons) and a 377 -nucleotide RNA molecule. It has been observed that the RNA molecule possesses at least part of the enzymatic activity of the complex. Hence, it is an example of ribozyme.

Klenow fragment

E. coli DNA polymerase I consists of a single polypeptide chain. Pol I carry out three enzymatic reactions that are performed by three distinct functional domains. Two fragments are obtained when DNA pol I is treated with trypsin/subtilisin in mild conditions. The larger fragment is called as Klenow fragment. This fragment is 602 amino acids in length. The function of the Klenow fragment is to add nucleotides to the 3' end and 3' -5' exonuclease activity.

Klenow fragment adds nucleotides by using complementary strand as reference. It cannot extend the DNA without the presence of the complementary strand. If any nucleotide is added by mistake and the base pair is wrong (i.e., if A is paired to G instead of T) then by using 3' -5' exonuclease activity present in Klenow fragment, this mispaired base pair is removed. In general the Klenow fragment has 5' -3' polymerase and exonuclease activity.

Questions

1. The enzymes used in rDNA technology includes with star activity is/are
a). Nucleases
b). Restriction enzymes
c). DNA ligase
d). All the above
2. The enzymes used in rDNA technology includes with star activity is/are
a). Kinase
b). Phosphatase
c). Reverse transcriptase
d). All the above
3. The enzymes used in rDNA technology includes with star activity is/are
a). Terminal Deoxynucleotide Transferase
b). RNaseP
c). Reverse transcriptase
d). All the above
4. The group of enzymes used in rDNA technology which cleave or cut the genetic material
a). **Nucleases**
b). RNaseP
c). Reverse transcriptase
d). All the above
5. Nucleases act on
a). DNA
b). RNA
c). Both a and b
d). None of the above
6. Nucleases act on
a). DNA
b). RNA
c). Both a and b
d). None of the above
7. The nomenclature of restriction enzymes was proposed by
a). Smith
b). Nattens
c). Both a and b
d). None of the above
8. The restriction enzymes are grouped into types
a). **3**
b). 5
c). 2
d). None of the above
9. The restriction enzymes used widely in rDNA technology is
a). Type I
b). **Type II**
c). Type III
d). None of the above
10. The restriction enzyme with star activity is/are
a). *EcoRI*
b). *BamHI*

c). *SalI*

d).All the above

11. DNA ligase joins the DNA molecule covalently by catalysing the formation of bonds between adjacent nucleotides.

a). Phosphodiester

b). Phosphotriester

c). Both a and b

d). None of the above

12. DNA ligase isolated is from

a). *E. coli*

b). T 4 bacteriophage

c). Both a and b

d). None of the above

13. DNA ligase isolated from and is widely used.

a). *E. coli*

b). T 4 bacteriophage

c). Both a and b

d). None of the above

14. Reverse transcriptase isolated from and is widely used.

a). *E. coli*

b). T 4 bacteriophage

c). Both a and b

d). None of the above

15. RNase P specifically cleaves at the of RNA.

a). 5' end

b). 3' end

c). Both a and b

d). None of the above

Vectors: The carriers of DNA molecules

DNA vectors and their properties

One of the most important elements in gene cloning is the vector, which in conjunction with the passenger DNA forms the recombinant DNA which can be propagated in suitable host cells. In order to perform its function, a vector must possess the following properties:

- They should be capable of autonomous replication in at least one host organism.
- They should be of small size, since this aids the preparation vector DNA and reduces the complexity of analyzing recombinant molecules. They should be capable of amplifying the cloned sequence by occurring in multiple copies. High copy number facilitates in maximizing expression of cloned genes.
- There should be a unique cleavage site for a range of restriction endonucleases. Occurrence of multiple cleavage sites reduces the likelihood of functional recombinant DNA formation.
- They should possess one or more genetic markers enabling easy selection of cloned molecules.
- They should permit detection by simple genetic tests, of the presence of passenger DNA inserted at cloning site.
- They should have appropriate transcriptional and translational signals located adjacent to cloning sites for better expression of cloned DNA sequences.
- They should have host specificity when there is biological containment for a vector.

A variety of different cloning vectors have been developed by using the items mentioned above as guidelines. They are as follows: **plasmids, phages, cosmids, phasmids, shuttle vectors, expression vectors** and **single stranded DNA**

Plasmids

Plasmids are self replicating, double stranded, circular DNA molecules that are maintained in bacteria as independent extra chromosomal entities. These are also found in some yeast but not in higher eukaryotes. Plasmids are widely distributed throughout the prokaryotes, vary in size from less than 1×10^6 to greater than 200×10^6 Da and are generally dispensable.

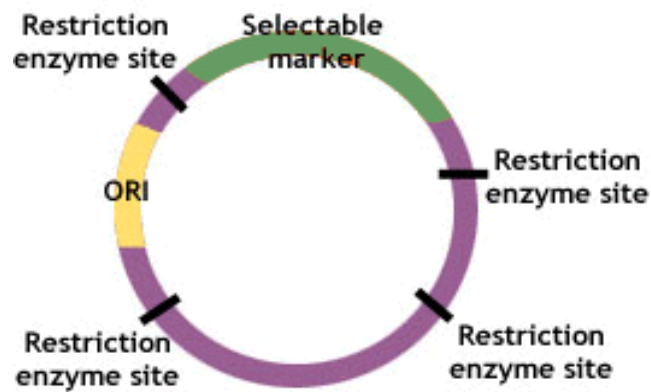
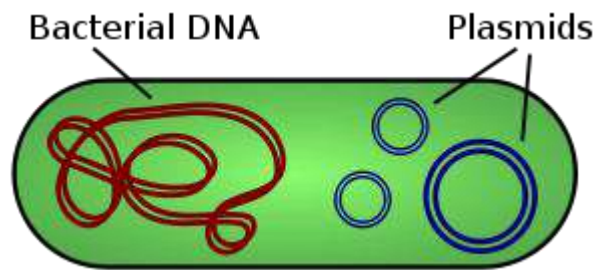

Plasmids can be grouped into two major types: **conjugative** and **non-conjugative**. In conjugative plasmids transfer genes (*tra*) and mobilizing genes (*mob*) are present whereas in non-conjugative plasmids *tra* genes are absent. The non-conjugative plasmids can be mobilized by another conjugative plasmid present in the same cell, if the *mob* gene is intact.

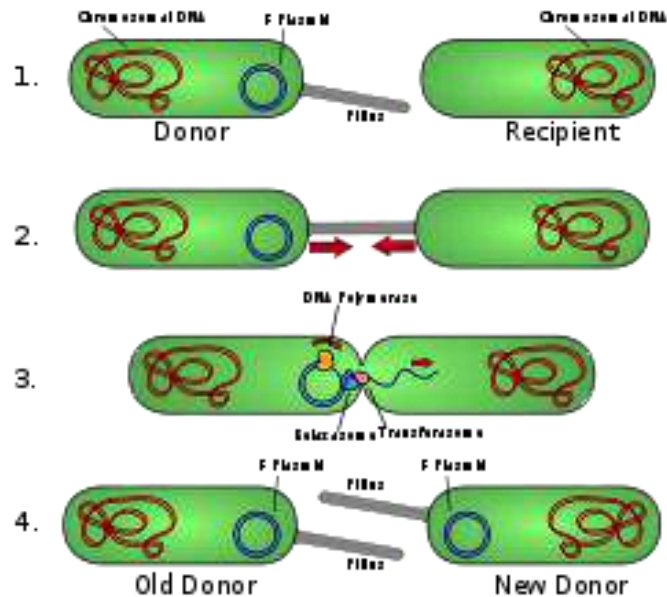

Non-conjugative differ from conjugative plasmids by the absence of *tra* gene Plasmids can also be categorized on the basis of their being maintained as multiple copies per cell (**relaxed plasmids** or **high copy number plasmids**) or as limited copies per cell (**stringent plasmids** or **low copy number plasmids**). The replication of stringent plasmids is coupled to chromosome replication, hence their low copy number. Generally conjugative plasmids are of low molecular weight and present in multiple copies per cell. An exception is the conjugative plasmids RBK which has a molecular weight of 25×10^6 daltons and is maintained as relaxed plasmid.

Plasmids that carry specific sets of genes for the utilization of unusual metabolites are called as **degradative plasmids**. Some plasmids will not have any apparent functional coding genes and are called **cryptic plasmids**. Some of the plasmids do not coexist in the same host cell in the absence of selection pressure and are called **incompatible plasmids**. Some plasmids are capable of promoting their own transfer to a wide range of host. These plasmids are called as **promiscuous plasmids**. Plasmids can also be grouped into **narrow-host range plasmids** and **wide host range plasmids** based on their nature of infectivity. Based on the origin of plasmids, they can be grouped into **naturally occurring plasmids** and **synthetic plasmids**.

A list of naturally occurring plasmids and their properties are furnished below.

Plasmid	Size (kb)	Conjugative	Copy number	Amplifiable	Selectable marker
ColE1	7.0	-	10 – 15	+	E1 ^{imm}
RSF1030	9.3	-	20 – 40	+	Apr
CloDF13	10.0	-	10	+	DF13 i m m
pSC101	9.7	-	1 -2	-	Tcr
R6K	42	+	10 – 40	-	Ap ^r Sm ^r
F	103	+	1 – 2	-	-
R1	108	+	1 – 2	-	Ap ^r Cm ^r Sn
RK2	56.4	+	3 – 5	-	Ap ^r Km ^r Tc ^r

In general plasmid cloning vectors are designated by a lowercase 'p' which stands for plasmid, and some abbreviations that may be descriptive.

pBR322 plasmid

Plasmid pBR322 is the one of the best studied and most often used "general purpose" plasmids. The BR of the pBR322 recognizes the work of the researchers F. Bolivar and R. Rodriguez, who created the plasmid and 322 is a numerical designation that has relevance to these workers. pBR322 is 4362 base pair long and completely sequenced. pBR322 carries two antibiotic resistance genes. One confers resistance to ampicillin (*Amp^r*) and the other confers resistance to tetracycline (*Tet^r*) There are eleven known enzymes which cleave pBR 322 at unique sites. For three of the enzymes, *Hind* III, *Bam* HI and *Sal* I, the target site lies within the *Tet^r* genes and for another two, *Pst* I and *Pru* I, they lie in *Amp^r* genes. Thus cloning in pBR 322 with the aid of these enzymes results in insertional inactivation where the inserted DNA disrupts the function of the gene containing the cloning site. Where the cloning site is within in an antibiotic resistance gene, such insertional inactivation results in transformants sensitive to the appropriate antibiotic. Thus, insertional inactivation helps in the selection of recombinants.

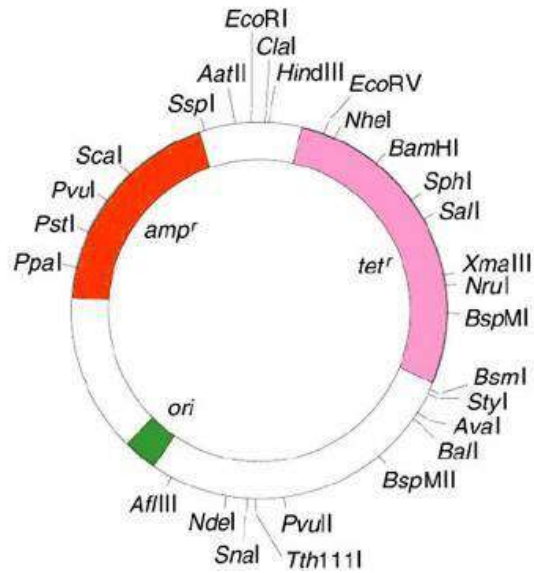

General structure of pBR322

pUC19 plasmid

Plasmid pUC19 is 2686 bp long and contains an ampicillin resistance (*Amp^r*) gene, a regulatable segment of β -galactosidase gene (*lacZ*) of the lactose operon of *E. coli*, *lac I* gene that produces a repressor protein that regulates the expression of *lacZ* gene, a short sequence with multiple cloning sites (*EcoRI*, *SacI*, *KpnI*, *XmaI*, *SmaI*, *BamHI*, *XbaI*, *SalI*, *HincII*, *AccI*, *BspMI*, *PstI*, *SphI* and *HindIII*) and the origin of replication from pBR322. The presence of *lacZ* and *lacI* genes allows to select the recombinants based on the β -galactosidase production in the presence of isopropyl- β -D-thiogalactopyranoside (IPTG), an inducer of the *lac* operon. (UC in pUC stands for University of California).

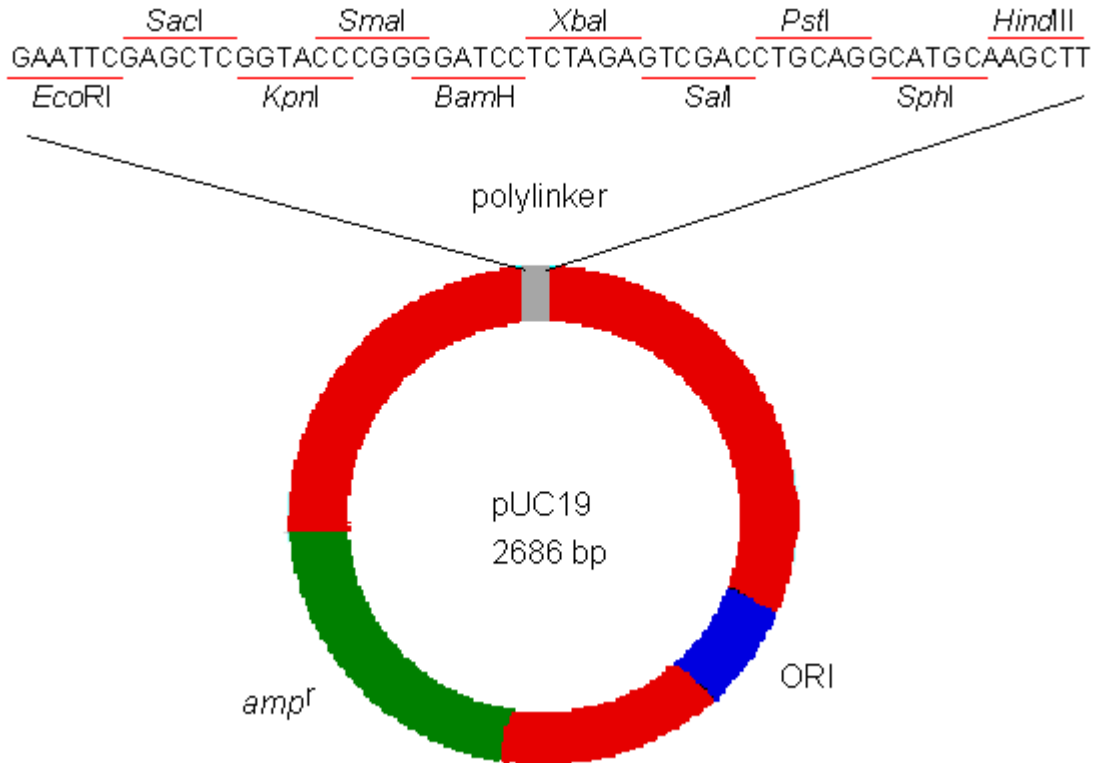

General structure of pUC19

Phages

Derivatives of phage have been developed as cloning vectors since the early days of gene technology. The phage derivatives are considered to be the most suitable cloning vehicles for cloning genomic eukaryotic DNA because of the following advantages over the plasmids.

- Thousands of phage plaques can be obtained in a single petridish.
- Selection by DNA-DNA hybridisation is possible
- *In vitro* packaging into empty phage head is possible thus increasing phage infectivity
- Size selection of the packaged DNA is possible
- Millions of independently cloned virus particle can be constituted to form a gene library.

Bacteriophage is a genetically complex but very extensively studied virus of *E. coli*. The DNA of phage, in the form in which it is isolated from the phage particle is a

linear duplex molecule of 48502 bp (~49kb) in length. The DNA isolated from virus particles is a double stranded linear molecule with short complementary single stranded projections of 12 nucleotides at its 5' ends. These cohesive termini, also referred to as **cos sites**, allow the DNA to be circularized after infection of the host cell.

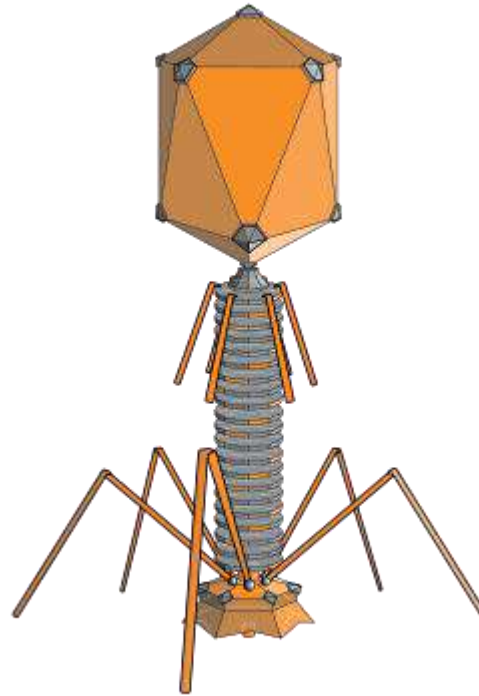

The structure of a typical tailed bacteriophage

The genetic map of phage λ comprises approximately 40 genes which are organized in functional clusters. Genes coding for head and tail are proteins (genes A-J) are on the left of the linear map. The central region contains genes, such as *int*, *xis*, *exo* etc. which are responsible for lysogenisation *i.e* the process leading to the integration of viral DNA and other recombination events. Much of this central region is not essential for lytic growth. Genes to the right of the central region comprise six regulatory genes, two genes (O and P) which are essential for DNA replication during lytic growth and two more genes (S and R) which are required for the lysis of the cellular membranes.

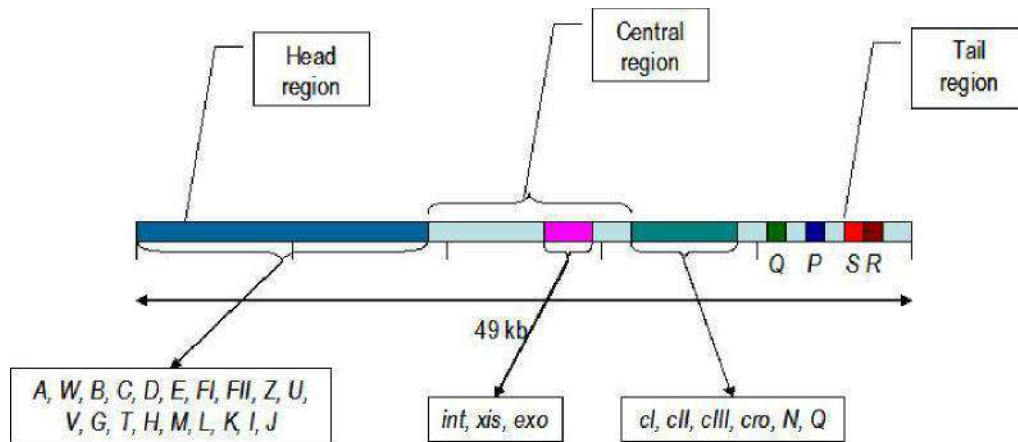

Genetic map of λ phage

In the phage DNA, larger central region is not essential for phage growth and replication. This region of phage can be deleted or replaced without seriously impairing the phage growth cycle. Using this non-essential region of phage λ , several phage vector derivatives have been constructed for efficient gene cloning.

Types of phage vectors

Wild type phage DNA itself cannot be used as a vector since it contains too many restriction sites. Further, these sites are often located within the essential regions for phage's growth and development. From these wild phages, derivatives with single target sites and two target sites have been synthesized. Phage vectors which contain single site for the insertion of foreign DNA have been designated as **insertional vectors**; vectors with two cleavage sites, which allow foreign DNA to be substituted for the DNA sequences between those sites, are known as **replacement vectors**. Apparently if too much non-essential DNA is deleted from the genome it cannot be packaged into phage particles efficiently. For both types of vector, the final recombinant genome must be between 39 and 52 kb of the wild type phage genome, if they are to be packaged into infectious particles. Insertion vectors must therefore be at least 39 kb in length to maintain their viability. This places an upper limit of about 12 kb for the size of foreign DNA fragments which can be inserted. Replacement vectors have a larger capacity because the entire non-essential region can be replaced, allowing the cloning of the fragments upto 22 kb. Several types of vectors have been developed which allow direct screening for recombinant phages and are useful for cloning specific DNA fragments. A list of phage vectors with their characteristics is given below.

Phage vector	Size (kb)	Enzyme	Size of insertion (kb)
Charon 4A	45.3	<i>EcoRI, XbaI</i>	7-20
ë L47.1	40.6	<i>EcoRI, HindIII,</i>	8.6-21.6
ë Dam sr1ë3	38.3	<i>EcoRI</i>	13
ë1059	44.0	<i>BamHI</i>	6.3-24.4

Cosmids

Plasmids containing phage **cos** sites are known as **cosmids**. Cosmids can be used to clone large fragments of DNA by exploiting the phage *in vitro* packaging system. Since cosmids have advantages of both plasmids and phage vectors they can be delivered to the host by the more efficient infection procedures rather than by transformation. Cloning with cosmid vectors has widened the scope of plasmid cloning in the following ways.

- The infectivity of plasmid DNA packaged in phage head is at least three orders of magnitude higher than that of pure plasmids DNA.
- The process almost exclusively yields hybrid clones so that a subsequent selection for recombinant DNA becomes unnecessary.
- In contrast to normal plasmid transformations, the system strongly selects for clones containing large DNA inserts. It is therefore, particularly well suited for generating genomic libraries.

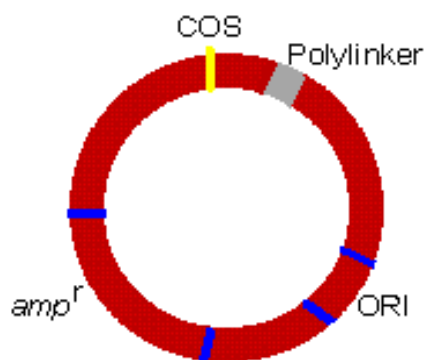

General structure of a cosmid vector

The following table provides a list of cosmid vectors and their structural features.

Cosmid	Size	Cleavage sites	Size of insertion (kb)
MUA3	4.76	<i>EcoRI/PstI/PvuII/PvuI</i>	40 – 48
pJB8	5.40	<i>BamHI</i>	32 – 45
Homer I	5.40	<i>EcoRI/ClaI</i>	30 – 47
Homer II	6.38	<i>SstI</i>	32 – 44
pJC79	6.40	<i>EcoRI/ClaI/BamHI</i>	32 – 44

Phasmids

Phasmids, also called as phagemids, are hybrids formed between small multicopy plasmids and bacteriophages. A phasmid can be propagated as a plasmid or lytically as a phage. Lytic functions of phasmid can be switched off by propagation in the appropriate lysogene where the plasmid origin of replication is used for maintenance. The phasmid may replicate as phage if propagated in a non-lysogenic strain. In the case of phasmids based on ϕ , such as ϕ 1130, the temperature sensitive gene, *cI857* carried by the vector may be used to switch between replication modes, simply by growing the host at the permissive (plasmid mode) or restrictive (phage mode) temperature.

Phasmids are particularly useful in the generation and analysis of mutations exhibiting non-selectable or lethal phenotypes, such as those affecting the replication of plasmids. Phasmids may also be used as phage replacement vectors and for directing the high level expression of protein from cloned sequences by replication in the phage mode.

Bacterial Artificial Chromosomes (BAC)

BACs are based on bacterial mini-F plasmids, which are small pieces of episomal bacterial DNA that give the bacteria the ability to initiate conjugation with adjacent bacteria. They have a cloning limit of 75-300 kb.

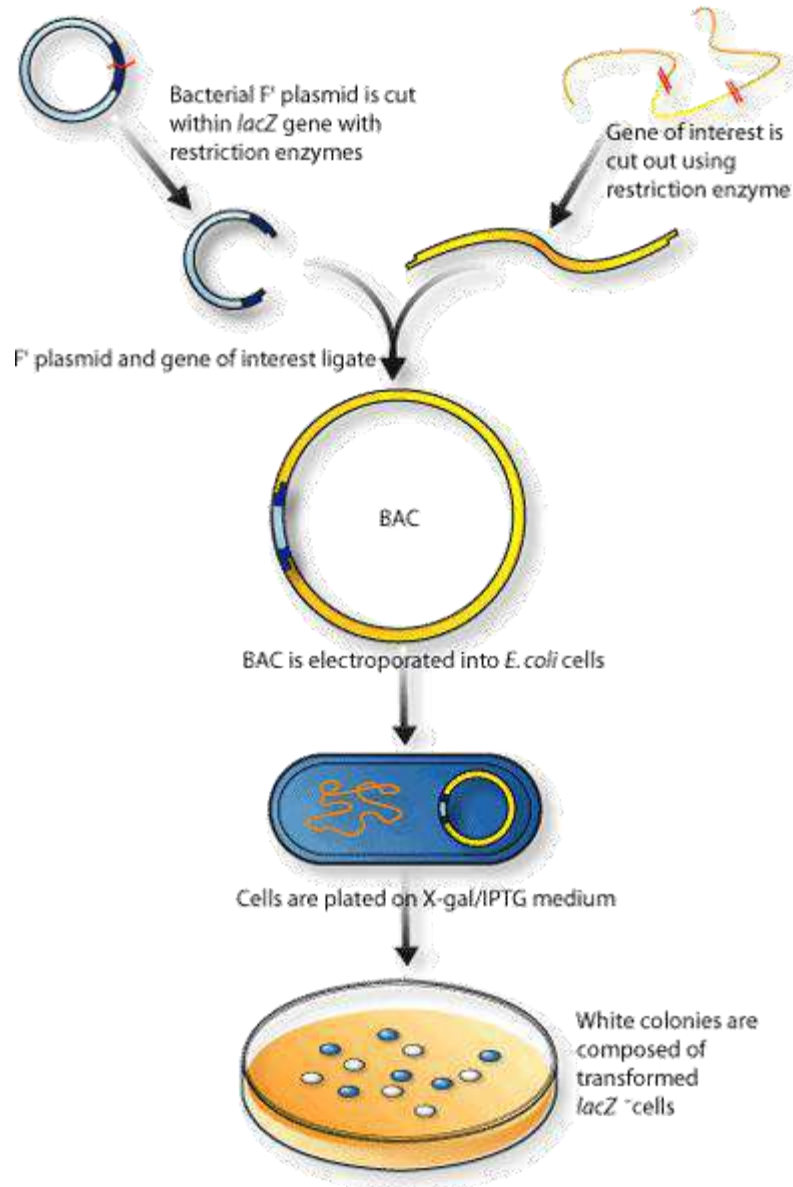

Transforming a bacterium using a BAC vector

Yeast Artificial Chromosomes (YAC)

- YACs are artificial chromosomes that replicate in yeast cells. They consist of:
- Telomeres, which are ends of chromosomes involved in the replication and stability of linear DNA.
- Origin of replication sequences necessary for the replication in yeast cells.
- A yeast centromere, which is a specialized chromosomal region where spindle fibers attach during mitosis.
- A selectable marker for identification in yeast cells.

- Ampicillin resistance gene for selective amplification.
- Recognition sites for restriction enzymes.

The procedure for making YAC vectors is as follows (see Appendix D):

1. The target DNA is partially digested by a restriction endonuclease, and the YAC vector is cleaved by restriction enzymes.
2. The cleaved vector segments are ligated with a digested DNA fragment to form an artificial chromosome.
3. Yeast cells are transformed to make a large number of copies.

They are the largest of the cloning vectors, with a cloning limit of 100-1000 kb, however they have very low efficiency.

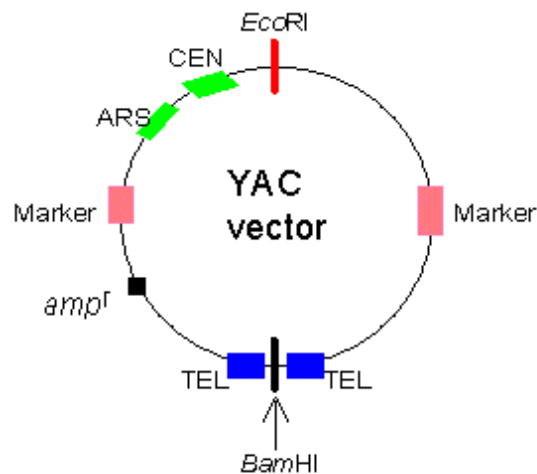

Shuttle vectors

Shuttle vectors normally comprise an *E. coli* plasmid or part of such plasmid (e.g., pBR 322), ligated *in vitro* to a plasmid or virus replicon from another species. Shuttle vectors can be made, for example, for *E. coli*/*B. subtilis*, *E. coli*/yeast or *E. coli*/mammalian cells. The shuttle vector strategy permits the exploitation of the many manipulative procedures, such as amplification, available in *E. coli* (or other genetically well characterized species such as *B. subtilis* or *S. cerevisiae*) backgrounds. The ability to transfer cloned genes across species boundaries is of potential value in the genetic manipulations of industrially important species and this can be achieved by using shuttle vectors.

Expression vectors

In DNA cloning experiments all the genes cloned are not expressed fully because of

weak promoters in vector DNA. This can be dramatically improved by placing such genes downstream of strong promoters. An additional problem in maximizing expression of cloned genes in *E. coli* which is frequently encountered with genes from a heterologous source is that the gene carries no translation start signal which can be efficiently recognized by the *E. coli* translation system. This problem may arise for heterologous genes cloned into any host. Thus, even though the gene can be transcribed from a promoter within the vector, the resulting mRNA is poorly translated and little or no protein product will be synthesized. In such cases alternative strategies available are fusing the gene to amino terminal region of vector gene that is efficiently translated in the host or coupling the gene to a DNA fragment carrying both strong promoter and a ribosomal binding site. Vectors with this additional feature are called **expression vectors**.

Host systems for cloned vectors *E. coli* system

Vectors and their hosts form integrated system for constructing and maintaining recombinant DNA molecules. The choice of a particular **host - vector system** depends on a variety of factors, including ease and safety of manipulations and the likelihood of expression of cloned genes. Among the host system *E. coli* system remains well exploited one. Several strains, such as x1776, have been disabled for use as safe host in potentially hazardous cloning experiments. Most cloning experiments can, however, be carried out with strains that are considerable less disabled and hence more easily handled than other hosts.

***Bacillus subtilis* system**

Bacillus subtilis is the best characterized of all Gram positive bacteria. It has a well defined genetic map and efficient systems for transformation and transfection. In addition, *B. subtilis* is commercially important since procedures for the synthesis of peptide antibiotic and extracellular enzymes, such as proteases are made available. Further, the species is nonpathogenic which makes it a safe host for cloning potentially hazardous genes. However, *B. subtilis* does sporulate readily, thus increasing the probability that cloned genes would survive outside the laboratory or fermentor. Asporogenous mutants with increased autolytic activity may however, be used as high containment host strains. Several other cloning systems such as systems of streptococci, staphylococci, streptomyces, etc. are developed for gene manipulation experiments.

Yeast host system

Actinomycetes host system is interesting for a number of reasons. The actinomycetes synthesize a wide range of metabolites which provide the majority of medically and agriculturally important antibiotics. Actinomycetes genes may also be the primary source of clinically important antibiotic resistance determinants. Finally they have a complex morphological development cycle which involves a series of changes from vegetative mycelial growth to spore formation. The real interest in gene cloning in actinomycetes is that it would facilitate the development of industrial strains which give increased antibiotic yields.

Questions

1. Vectors used in rDNA technology should possess
 - a). Autonomous replication
 - b). Small size
 - c). Possess one or more genetic markers
 - d). All the above**
2. Plasmids DNA is
 - a). Self replicating
 - b). Double stranded
 - c). Circular
 - d). All the above**
3. Plasmids are grouped into major types
 - a). 2**
 - b). 3
 - c). 4
 - d). None of the above
4. Conjugative plasmids have genes
 - a). Only transfer genes (*tra*)
 - b). Only mobilizing genes (*mob*)
 - c). Both a and b**
 - d). Promiscuous plasmids
5. Non - conjugative plasmids have genes
 - a). Only transfer genes (*tra*)
 - b). Only mobilizing genes (*mob*)**
 - c). Both a and b
 - d). Promiscuous plasmids
6. Relaxed plasmids are also called as
 - a). High copy number plasmids**
 - b). Stringent plasmids
 - c). Low copy number plasmids
 - d). Promiscuous plasmids
7. Stringent plasmids are also called as
 - a). High copy number plasmids
 - b). Relaxed plasmids
 - c). Low copy number plasmids**
 - d). Promiscuous plasmids
8. Plasmids that carry specific sets of genes for the utilization of unusual metabolites are called as
 - a). Degradative plasmids**
 - b). Relaxed plasmids
 - c). Stringent plasmids
 - d). Promiscuous plasmids
9. Plasmids without any apparent functional coding genes are called as
.....
 - a). Degradative plasmids
 - b). Cryptic plasmids**
 - c). Stringent plasmids
 - d). Promiscuous plasmids

18. Phasmids are hybrids formed between

- a). **Plasmids and bacteriophages**
- b). Cosmids and bacteriophages
- c). BAC and bacteriophages
- d). None of the above

19. Bacterial Artificial Chromosomes (BAC) are

- a). Mini-F plasmids
- b). Have the ability to initiate conjugation with adjacent bacteria
- c). Have a cloning limit of 75-300 kb
- d). **All the above**

20. Yeast Artificial Chromosomes (YAC) are

- a). Artificial chromosomes that replicate in yeast cells
- b). Have recognition sites for restriction enzymes
- c). Have ampicillin resistance gene for selective amplification
- d). **All the above**

21. Yeast Artificial Chromosomes (YAC) are

- a). The largest of the cloning vectors
- b). Cloning limit of 100-1000 kb
- c). Very low efficiency
- d). **All the above**

Gene cloning

A **clone** is an exact copy of an organism, organ, single cell, organelle or macromolecule. Gene cloning is the act of making copies of a single gene. **Molecular cloning** refers to the procedure of isolating a defined DNA sequence and obtaining multiple copies of it *in vivo*. Cloning is frequently employed to amplify DNA fragments containing genes, but it can be used to amplify any DNA sequence such as promoters, non-coding sequences, chemically synthesised oligonucleotides and randomly fragmented DNA. Cloning is used in a wide array of biological experiments and technological applications such as large scale protein production. It is used in many areas of research and for medical applications such as gene therapy. Selective amplification of genes depends on the ability to perform the following essential procedures.

1. Amplification of a specific gene

The discovery of thermostable DNA polymerases, such as Taq Polymerase, made it possible to manipulate DNA replication in the laboratory and was essential to the development of the polymerase chain reaction (PCR). Primers specific to a particular region of DNA, on either side of the gene of interest, are used, and replication is stopped and started repetitively, generating millions of copies of that gene. These copies can then be separated and purified using gel electrophoresis.

2. Cutting DNA at precise locations

The discovery of enzymes known as restriction endonucleases has been essential to protein engineering. These enzymes cut DNA at specific locations based on the nucleotide sequence. Hundreds of different restriction enzymes, capable of cutting DNA at a distinct site, have been isolated from many different strains of bacteria. DNA cut with a restriction enzyme produces many smaller fragments, of varying sizes. These can be separated using gel electrophoresis or chromatography.

3. Join two pieces of DNA

In genetic research it is often necessary to link two or more individual strands of DNA, to create a longer strand, or close a circular strand that has been cut with restriction enzymes. Enzymes called DNA ligases can create covalent bonds between nucleotide

chains. The enzymes DNA polymerase I and polynucleotide kinase are also important in this process, for filling in gaps, or phosphorylating the 5' ends, respectively.

4. Selection of small self-replicating DNA

Small circular pieces of DNA that are not part of a bacterial genome, but are capable of self-replication, are known as plasmids. Plasmids are often used as “vectors” to transport genes between microorganisms. In biotechnology, once the gene of interest has been amplified and both the gene and plasmid are cut by restriction enzymes, they are ligated together generating what is known as a recombinant DNA. Viral (bacteriophage) DNA can also be used as a vector, as can cosmids, recombinant plasmids containing bacteriophage genes.

5. Method to move a vector into a host cell

The process of transferring plasmids into new host cells is called transformation. This technique requires that the host cells are exposed to a heat-shock, which makes them “competent” or permeable to the plasmid DNA. The larger the plasmid, the lower the efficiency with which it is taken up by cells. Larger DNA segments are more easily cloned using bacteriophage vectors or cosmids.

6. Method to select hosts expressing recombinant DNA

Not all cells will take up DNA during transformation. It is essential that there be a method of detecting the ones that do. Generally, plasmids carry genes for antibiotic resistance and transformed cells can be selected based on expression of those genes and their ability to grow on media containing that antibiotic. Alternative methods of selection depend on the presence of other reporter proteins such as the x-gal/ *lacZ* system, or green fluorescence protein, which allow selection based on color and fluorescence, respectively.

Questions:

1. A clone is an exact copy of
a). An organism
b). Organ
c). Single cell
d). All the above

2. Molecular cloning refers to
a). Isolating a defined DNA sequence
b). Obtaining multiple copies of defined DNA sequence *in vivo*
c). Both a and b
d). None of the above

3. Cloning is frequently employed to amplify
a). DNA fragments containing genes
b). DNA sequence such as promoters, non-coding sequences
c). Chemically synthesised oligonucleotides
d). All the above

4. Cloning is mainly used for
a). Large scale protein production
b). Gene therapy
c). Both a and b
d). None of the above

5. Taq polymerase is
a). Thermostable
b). Thermounstable
c). Thermoliable
d). None of the above

6. enzymes cut DNA at specific locations based on the nucleotide sequence.
a). Restriction enzymes
b). DNA ligase
c). Nuclease
d). None of the above

7. enzymes unite DNA segments
a). Restriction enzymes
b). DNA ligase
c). Nuclease
d). None of the above

8. DNA ligases create bonds between nucleotide chains.
a). Covalent
b). Hydrogen
c). Ionic
d). None of the above

9. The process of transferring plasmids into new host cells is called
a). Transformation
b). Transduction
c).
d). None of the above

10. The larger the plasmid,is the efficiency with which it is taken up by cells.

a). Lower

b). Higher

c). Medium

d). None of the above

Additional readings..

[http://highered.mcgraw-](http://highered.mcgraw-hill.com/olcweb/cgi/pluginpop.cgi?it=swf::535::535::/sites/dl/free/0072437316/120078/micro10.swf::Steps%20in%20Cloning%20a%20Gene)

[hill.com/olcweb/cgi/pluginpop.cgi?it=swf::535::535::/sites/dl/free/0072437316/120078/micro10.swf::Steps%20in%20Cloning%20a%20Gene](http://highered.mcgraw-hill.com/olcweb/cgi/pluginpop.cgi?it=swf::535::535::/sites/dl/free/0072437316/120078/micro10.swf::Steps%20in%20Cloning%20a%20Gene)

<http://biotech.about.com/od/cloning/tp/DNAcloning.htm>

[http://highered.mcgraw-](http://highered.mcgraw-hill.com/olcweb/cgi/pluginpop.cgi?it=swf::535::535::/sites/dl/free/0072437316/120078/micro10.swf::Steps%20in%20Cloning%20a%20Gene)

[hill.com/olcweb/cgi/pluginpop.cgi?it=swf::535::535::/sites/dl/free/0072437316/120078/micro10.swf::Steps%20in%20Cloning%20a%20Gene](http://highered.mcgraw-hill.com/olcweb/cgi/pluginpop.cgi?it=swf::535::535::/sites/dl/free/0072437316/120078/micro10.swf::Steps%20in%20Cloning%20a%20Gene)

Gene delivery methods in plants

For production of transgenic animals, DNA is usually microinjected into pronuclei of embryonic cells at a very early stage after fertilization, or alternatively gene targeting of embryo stem (ES) cells is employed. This is possible in animals due to the availability of specialized *in vitro* fertilization technology, which allows manipulation of ovule, zygote or early embryo.

Such techniques are not available in plants. In contrast to this in higher plants, cells or protoplasts can be cultured and used for regeneration of whole plants. Therefore, these protoplasts can be used for gene transfer followed by regeneration leading to the production of transgenic plants. Besides cultured cells and protoplasts, other meristem cells (immature embryos or organs), pollen or zygotes can also be used for gene transfer in plants. The enormous diversity of plant species and the availability of diverse genotypes in a species, made it necessary to develop a variety of techniques, suiting different situations. These different methods of gene transfer in plants are discussed.

Target cells for gene transformation

The first step in gene transfer technology is to select cells that are capable of giving rise to whole transformed plants. Transformation without regeneration and regeneration without transformation are of limited value. In many species, identification of these cell types is difficult. This is unlike the situation in animals, because the plant cells are totipotent and can be stimulated to regenerate into whole plants *in vitro* via organogenesis or embryogenesis. However, *in vitro* plant regeneration imposes a degree of 'genome stress', especially if plants are regenerated via a callus phase. This may lead to chromosomal or genetic abnormalities in regenerated plants a phenomenon referred to as soma clonal variation.

In contrast to this, gene transfer into pollen (or possibly egg cells) may give rise to genetically transformed gametes, which if used for fertilization (*in vivo*) may give rise to transformed whole plants. Similarly, insertion of DNA into zygote (*in vivo* or *in vitro*) followed by embryo rescue, may also be used to produce transgenic plants. Another alternative approach is the use of individual cells in embryos or meristems, which may be grown *in vitro* or may be allowed to develop normally for the production of transgenic plants.

Vectors for gene transfer

Most vectors carry marker genes, which allow recognition of transformed cells (other cells die due to the action of an antibiotic or herbicide) and are described as selectable markers. Among these marker genes, the most common selectable marker is npt II, providing kanamycin resistance. Other common features of suitable transformation vector include the following: (i) multiple unique restriction sites (a synthetic polylinker); (ii) bacterial origins of replication (e.g. ColE1).

The vectors having these properties may not necessarily have features, which facilitate their transfer to plant cells or integration into the plant nuclear genome. Therefore, *Agrobacterium* Ti plasmid is preferred over all other vectors, because of wide host range of this bacterial system and the capacity to transfer genes due to the presence of T - DNA border sequences.

Gene delivery methods

To achieve genetic transformation in plants, we need the construction of a vector (genetic vehicle) which transports the genes of interest, flanked by the necessary controlling sequences *i.e.* promoter and terminator, and deliver the genes into the host plant. The two kinds of gene transfer methods in plants are:

Vector-mediated or indirect gene transfer

Among the various vectors used in plant transformation, the Ti plasmid of ***Agrobacterium tumefaciens*** has been widely used. This bacterium is known as “natural genetic engineer” of plants because these bacteria have natural ability to transfer T-DNA of their plasmids into plant genome upon infection of cells at the wound site and cause an unorganized growth of a cell mass known as crown gall. Ti plasmids are used as gene vectors for delivering useful foreign genes into target plant cells and tissues. The foreign gene is cloned in the T-DNA region of Ti-plasmid in place of unwanted sequences. To transform plants, leaf discs (in case of dicots) or embryogenic callus (in case of monocots) are collected and infected with ***Agrobacterium*** carrying recombinant disarmed Ti-plasmid vector. The infected tissue is then cultured (co-cultivation) on shoot regeneration medium for 2-3 days during which time the transfer of T-DNA along with foreign genes takes place. After this, the transformed tissues (leaf discs/calli) are transferred onto selection cum plant regeneration medium supplemented with usually lethal concentration of an antibiotic to selectively eliminate non-transformed tissues. After 3-5 weeks, the regenerated shoots (from leaf discs) are transferred to root-inducing medium, and after another 3-

4 weeks, complete plants are transferred to soil following the hardening (acclimatization) of regenerated plants. The molecular techniques like PCR and southern hybridization are used to detect the presence of foreign genes in the transgenic plants.

Structure and functions of Ti and Ri Plasmids

The most commonly used vectors for gene transfer in higher plants are based on tumour inducing mechanism of the soil bacterium *Agrobacterium tumefaciens*, which is the causal organism for crown gall disease, A closely related species *A. rhizogenes* causes hairy root disease. An understanding of the molecular basis of these diseases led to the utilization of these bacteria for developing gene transfer systems. It has been shown that the disease is caused due to the transfer of a DNA segment from the bacterium to the plant nuclear genome. The DNA segment, which is transferred is called T - DNA and is part of a large Ti (tumour inducing) plasmid found in virulent strains of *Agrobacterium tumefaciens*. Similarly Ri (root inducing) megaplasmids are found in the virulent strains of *A. rhizogenes*.

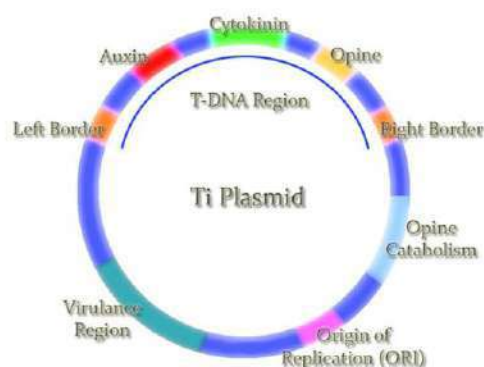

Most Ti plasmids have four regions in common, (i) Region A, comprising T-DNA is responsible for tumour induction, so that mutations in this region lead to the production of tumours with altered morphology (shooty or rooty mutant galls). Sequences homologous to this region are always transferred to plant nuclear genome, so that the region is described as T-DNA (transferred DNA). (ii) Region B is responsible for replication. (iii) Region C is responsible for conjugation. (iv) Region D is responsible for virulence, so that mutation in this region abolishes virulence. This region is therefore called virulence (v) region and plays a crucial role in the transfer of T-DNA into the plant nuclear genome. The components of this Ti plasmid have been used for developing efficient plant transformation vectors.

The T-DNA consists of the following regions: (i) An one region consisting of three genes (two genes *tms* and *tms2* representing 'shooty locus' and one gene *tmr* representing 'rooty locus') responsible for the biosynthesis of two phytohormones, namely indole acetic acid (an auxin) and isopentyladenosine 5'-monophosphate (a cytokinin). These genes encode the enzymes responsible for the synthesis of these phytohormones, so that the incorporation of these genes in plant nuclear genome leads to the synthesis of these phytohormones in the host plant. The phytohormones in their turn alter the developmental programme, leading to the formation of crown gall (ii) An *os* region responsible for the synthesis of unusual amino acid or sugar derivatives, which are collectively given the name opines. Opines are derived from a variety of compounds (e.g. arginine + pyruvate), that are found in plant cells. Two most common opines are octopine and nopaline. For the synthesis of octopine and nopaline, the corresponding enzymes octopine synthase and nopaline synthase are coded by T- DNA.

Depending upon whether the Ti plasmid encodes octopine or nopaline, it is described as octopine-type Ti plasmid or nopaline-type Ti plasmid. Many organisms including higher plants are incapable of utilizing opines, which can be effectively utilized by *Agrobacterium*. Outside the T-DNA region, Ti plasmid carries genes that, catabolize the opines, which are utilized as a source of carbon and nitrogen. The T-DNA regions on all Ti and Ri plasmids are flanked by almost perfect 25bp direct repeat sequences, which are essential for T-DNA transfer, acting only in *cis* orientation. It has also been shown that any DNA sequence, flanked by these 25bp repeat sequences in the correct orientation, can be transferred to plant cells, an attribute that has been successfully utilized for *Agrobacterium* mediated gene transfer in higher plants leading to the production of transgenic plants.

Besides 25bp flanking border sequences (with T DNA), *vir* region is also essential for T-DNA transfer. While border sequences function in *cis* orientation with respect to T - DNA, *vir* region is capable of functioning even in *trans* orientation. Consequently physical separation of T-DNA and *vir* region onto two different plasmids does not affect T-DNA transfer, provided both the plasmids are present in the same *Agrobacterium* cell. This property played an important role in designing the vectors for gene transfer in higher plants, as will be discussed later. The *vir* region (approx 35 kbp) is organized into six operons, namely *vir A*, *vir B*, *vir C*, *vir D*, *vir E*, and *vir G*, of which four operons (except *vir A* and *vir G*) are polycistronic. Genes *vir A*, *B*, *D*,

and G are absolutely required for virulence; the remaining two genes vir C and E are required for tumour formation. The vir A locus is expressed constitutively under all conditions.

The vir G locus is expressed at low levels in vegetative cells, but is rapidly induced to higher expression levels by exudates from wounded plant tissue. The vir A and vir G gene products regulate the expression of other vir loci. The vir A product (Vir A) is located on the inner membrane of *Agrobacterium* cells and is probably a chemoreceptor, which senses the presence of phenolic compounds (found in exudates of wounded plant tissue), such as acetosyringone and β -hydroxyacetosyringone. Signal transduction proceeds via activation (possibly phosphorylation) of Vir G (product of gene vir G), which in its turn induces expression of other vir genes.

Transformation techniques using *Agrobacterium*

Agrobacterium infection (utilizing its plasmids as vectors) has been extensively utilized for transfer of foreign DNA into a number of dicotyledonous species. The only important species that have not responded well, are major seed legumes, even though transgenic soybean (*Glycine max*) plants have been obtained. The success in this approach for gene transfer has resulted from improvement in tissue culture technology. However, monocotyledons could not be successfully utilized for *Agrobacterium* mediated gene transfer except a solitary example of *Asparagus*. The reasons for this are not fully understood, because T-DNA transfer does occur at the cellular level. It is possible that the failure in monocots lies in the lack of wound response of monocotyledonous cells.

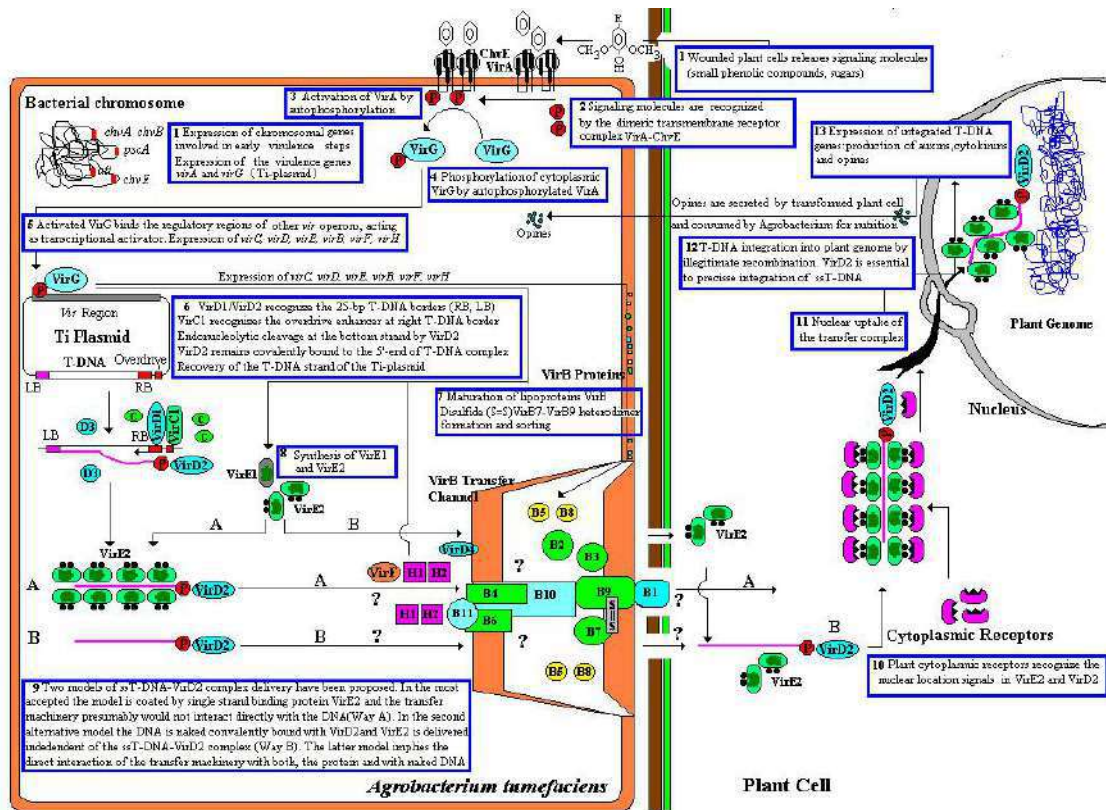

<http://www.ejbiotechnology.info/content/vol1/issue3/full/1/figure1.html>

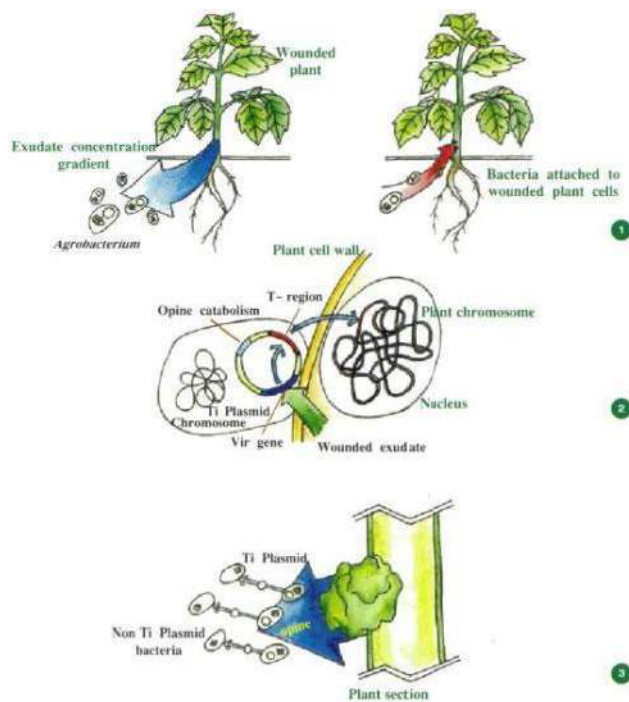

Vectorless or direct gene transfer

In the direct gene transfer methods, the foreign gene of interest is delivered into the host plant cell without the help of a vector. The gene transfer system using genetically engineered vectors do not work out well particularly in monocot species. Considering the problem, direct gene transfer methods have been tried and the methods used for direct gene transfer in plants are:

Chemical mediated gene transfer

Direct DNA uptake by protoplasts can be stimulated by chemicals like polyethylene glycol (PEG). This method was reported by **Krens** and his colleagues in 1982. The technique is so efficient that virtually every protoplast system has proven transformable. PEG is also used to stimulate the uptake of liposomes and to improve the efficiency of electroporation. PEG at high concentration (15-25%) will precipitate ionic macromolecules such as DNA and stimulate their uptake by endocytosis without any gross damage to protoplasts. This is followed by cell wall formation and initiation of cell division. These cells can now be plated at low density on selection medium. Initial studies using the above method were restricted to *Petunia* and *Nicotiana*.

However, other plant systems (rice, maize, etc.) were also successfully used later. In these methods, PEG was used in combination with pure Ti plasmid, or calcium phosphate precipitated Ti plasmid mixed with a carrier DNA. Transformation frequencies upto 1 in 100 have been achieved by this method. Nevertheless, there are serious problems in using this method for getting transgenic plants and all these problems relate to plant regeneration from protoplasts.

Microinjection and Macroinjection

Plant regeneration from transformed protoplasts, still remains a problem. Therefore cultured tissues, that encourage the continued development of immature structures, provide alternate cellular targets for transformation. These immature structures may include immature embryos, meristems, immature pollen, germinating pollen, isolated ovules, embryogenic suspension cultured cells, etc. The main disadvantage of this technique is the production of chimeric plants with only a part of the plant transformed. However, from this chimeric plant, transformed plants of single cell origin can be subsequently obtained. Utilizing this approach, transgenic chimeras have actually been obtained in oilseed rape (*Brassica napus*).

When cells or protoplasts are used as targets in the technique of microinjection, glass micropipettes with 0.5-10 μ m diameter tip are used for transfer of macromolecules into the cytoplasm or the nucleus of a recipient cell or protoplast. The recipient cells are immobilized on a solid support (cover slip or slide, etc.) or artificially bound to a substrate or held by a pipette under suction (as done in animal systems). Often a specially designed micromanipulator is employed for microinjecting the DNA. Although, this technique gives high rate of success, the process is slow, expensive and requires highly skilled and experienced personnel.

The microinjection method was introduced by two groups of scientist led by **Crossway** and **Reich** in 1986. Recently a method known as "holding pipette method" was introduced. In this, the protoplasts are isolated from cell suspension culture are placed on a depression slide, by its side with a microdroplet of DNA solution. Using the holding pipette, the protoplast has to be held and the DNA to be injected into the nucleus using the injection pipette. After the micro injection the injected cells are cultured by hanging droplet culture method.

DNA macroinjection employing needles with diameters greater than cell diameter has also been tried. In rye (*Secale cereale*), a marker gene was macroinjected into the stem below the immature floral meristem, so as to reach the sporogenous tissue (De la Pena *et al.*, 1987) leading to successful production of transgenic plants. Unfortunately, this technique could not be successfully repeated with any other cereal, when tried in several laboratories. Therefore, doubt is expressed about the validity of earlier experiments conducted with rye (Potrykus, 1991).

Electroporation method

Electroporation is another efficient method for the incorporation of foreign DNA into protoplasts, and thus for direct gene transfer into plants. This method was introduced by **Fromm** and his coworkers in 1986.

This method is based on the use of short electrical impulses of high field strength. These impulses increase the permeability of protoplast membrane and facilitate entry of DNA molecules into the cells, if the DNA is in direct contact with the membrane. In view of this, for delivery of DNA to protoplasts, electroporation is one of the several routine techniques for efficient transformation. However, since regeneration from protoplasts is not always possible, cultured cells or tissue explants are often used. Consequently, it is important to test whether electroporation could transfer genes into

walled cells. In most of these cases no proof of transformation was available.

The electroporation pulse is generated by discharging a capacitor across the electrodes in a specially designed electroporation chamber. Either a high voltage (1.5 kV) rectangular wave pulse of short duration or a low voltage (350V) pulse of long duration is used. The latter can be generated by a home made machine. Protoplasts in an ionic solution containing the vector DNA are suspended between the electrodes, electroporated and then plated as usual. Transformed colonies are selected as described earlier. Using electroporation method, successful transfer of genes was achieved with the protoplasts of tobacco, petunia, maize, rice, wheat and sorghum. In most of these cases cat gene associated with a suitable promoter sequence was transferred. Transformation frequencies can be further improved by (i) using field strength of 1.25kV/cm, (ii) adding PEG after adding DNA, (iii) heat shocking protoplasts at 45°C for 5 minutes before adding DNA and (iv) by using linear instead of circular DNA.

Microprojectiles or biolistics or particle gun for gene transfer

In 1987, **Klein** and his colleagues evolved a method by which the delivery of DNA into cells of intact plant organs or cultured cells is done by a process called Projectile Bombardment. The micro-projectiles (small high density particles) are accelerated to high velocity by a particle gun apparatus. These particles with high kinetic energy penetrate the cells and membranes and carry foreign DNA inside of the bombarded cells. This method is otherwise called as "Biolistics Method". In recent years, it has been shown that DNA delivery to plant cells is also possible, when heavy microparticles (tungsten or gold) coated with the DNA of interest are accelerated to a very high initial velocity (1,400 ft per, sec). These microprojectiles, normally 1-3µm in diameter, are carried by a 'macroprojectile' or the 'bullet' and are accelerated into living plant cells (target cells can be pollen, cultured cells, cells in differentiated tissues and meristems) so that they can penetrate cell walls of intact tissue. The acceleration is achieved either by an explosive charge (cordite explosion) or by using shock waves initiated by a high voltage electric discharge. The design of two particle guns used for acceleration of microprojectiles.



Gene gun

Transformed plants using the above technique have been obtained in many cases including soybean, tobacco, maize, rice, wheat, etc.. Transient expression of genes transferred in cells by this method has also been observed in onion, maize, rice and wheat. There is no other gene transfer approach, which has met with so much of enthusiasm. Consequently considerable investment has been made in experimentation and manpower for development of this technique.

Sonication Method: This is a simple technique recently (1990) formulated by **Xu** and his coworkers. In this method the explants (especially leaves) are excised and cut into segments, immersed in sonication buffer containing plasmid DNA and Carrier DNA in a sterile glass petridish. Then the samples were sonicated with an ultrasonic pulse generator at 0.5 c/cm² acoustic intensity for 30 minutes. After 30 minutes, the explants were rinsed in buffer solution without DMSO and transferred to the culture medium.

Transformation

This method is used for introducing foreign DNA into bacterial cells e.g. *E. Coli*. The transformation frequency (the fraction of cell population that can be transferred) is very good in this method. E.g. the uptake of plasmid DNA by *E. coli* is carried out in ice cold CaCl₂ (0-50C) followed by heat shock treatment at 37-450C for about 90 sec. The transformation efficiency refers to the number of transformants per microgram of added DNA. The CaCl₂ breaks the cell wall at certain regions and binds the DNA to the cell surface.

Conjunction

It is a natural microbial recombination process and is used as a method for gene

transfer. In conjunction, two live bacteria come together and the single stranded DNA is transferred via cytoplasmic bridges from the donor bacteria to the recipient bacteria.

Liposome mediated gene transfer or Lipofection

Liposomes are small lipid bags, in which large number of plasmids are enclosed. They can be induced to fuse with protoplasts using devices like PEG, and therefore have been used for gene transfer. The technique, offers following advantages: (i) protection of DNA/RNA from nuclease digestion, (ii) low cell toxicity, (iii) stability and storage of nucleic acids due to encapsulation in liposomes, (iv) high degree of reproducibility and (v) applicability to a wide range of cell types.

In this technique, DNA enters the protoplasts due to endocytosis of liposomes, involving the following steps: (i) adhesion of the liposomes to the protoplast surface, (ii) fusion of liposomes at the site of adhesion and (iii) release of plasmids inside the cell. The technique has been successfully used to deliver DNA into the protoplasts of a number of plant species (e.g. tobacco, petunia, carrot, etc.).

Gene transformation using pollen or pollen tube

There has been a hope that DNA can be taken up by the germinating pollen and can either integrate into sperm nuclei or reach the zygote through the pollen tube pathway. Both these approaches have been tried and interesting phenotypic alterations suggesting gene transfer have been obtained. In no case, however, unequivocal proof of gene transfer has been available. In a number of experiments, when marker genes were used for transfer, only negative results were obtained. Several problems exist in this method and these include the presence of cell wall, nucleases, heterochromatic state of acceptor DNA, callose plugs in pollen tube, etc. Transgenic plants have never been recovered using this approach and this method, though very attractive, seems to have little potential for gene transfer.

Calcium phosphate precipitation method for gene transfer

Foreign DNA can also be carried with the Ca ++ ions, to be released inside the cell due to the precipitation of calcium in the form of calcium phosphate. In the past, this method was considered to be very important for gene transfer in plants.

Incubation of dry seeds, embryos, tissues or cells in DNA

Incubation of dry seeds, embryos, tissues or cells in known DNA (viral or non viral having defined marker genes) has been tried in many cases and expression of

defined genes has been witnessed. However, in no case proof of integrative transformation could be available. In all these cases, plant cell walls not only work as efficient barriers, but are also efficient traps for DNA molecules. It would be very surprising if DNA can cross cell walls efficiently without permeabilizing them either by PEG, or by electroporation or by any other device.

Selection of transformed cells from untransformed cells

The selection of transformed plant cells from untransformed cells is an important step in the plant genetic engineering. For this, a marker gene (e.g. for antibiotic resistance) is introduced into the plant along with the transgene followed by the selection of an appropriate selection medium (containing the antibiotic). The segregation and stability of the transgene integration and expression in the subsequent generations can be studied by genetic and molecular analyses (Northern, Southern, Western blot, PCR).

Though several methods have been described for gene transfer using naked DNA, the recovery of genetic recombinants, otherwise called as "transgenic plants" appears to be a rare phenomenon. A concerted effort

- To accurately identify genes which can be shown to influence agronomically important characters
- To apply the technique to clone the isolated genes
- To anneal them to appropriate vectors and
- To evaluate their expression in agronomically important crop varieties will solve the deficiencies in the conventional breeding procedures.

The last five years have seen successful outcomes and transgenic plants have been produced in some crop species by using both vector mediated and direct gene transfer techniques. However, all the programmes were not successful because of lack of proofs for the integrative gene transfer. Considering the needs to have integrative gene transfer, **Potrykus** points out that all the successful gene transfers should have the following proofs.

1. Serious controls for treatments and analysis.
2. A tight correlation between treatment and predicted results.
3. A tight correlation between physical (Southern blot, *in situ* hybridization) and phenotypic data.

4. Complete Southern Analysis to show the hybrid fragments of host DNA and foreign DNA, and the absence or presence of contaminating fragments.
5. Data that allow discrimination between false positives and correct transformants in the evaluation of the phenotypic evidence.
6. Correlation of the physical and phenotypic evidence with transmission to sexual offspring, as well as genetic and molecular analysis of offspring populations.

Questions

- The vectors used in genetic engineering should possess
 - Multiple unique restriction sites
 - Bacterial origins of replication
 - Marker genes, which allow recognition of transformed cells
 - All the above
- Agrobacterium* Ti plasmid is preferred over all other vectors because
 - Wide host range
 - Capacity to transfer genes due to the presence of T - DNA border sequences
 - Both a and b**
 - None of the above
- The natural genetic engineer is
 - Agrobacterium tumefaciens***
 - Bacillus subtilis*
 - E. coli*
 - None of the above
- Agrobacterium tumefaciens* causes
 - Crown gall**
 - Hairy root
 - Root rot*
 - None of the above
- Agrobacterium rhizogenes* causes
 - Crown gall
 - Hairy root**
 - Root rot*
 - None of the above
- Ti plasmids have regions in common.
 - 4**
 - 5
 - 3
 - None of the above
- Region which is responsible for tumour induction in Ti plasmids is
 - Region A**
 - Region B
 - Region C
 - Region D
- T-DNA region of Ti plasmids is
 - Region A**
 - Region B
 - Region C
 - Region D
- Region B is responsible for
 - Tumour induction
 - Replication**
 - Conjugation
 - Virulence
- Region A is responsible for

- a). **Tumour induction**
c). Conjugation
- b). Replication
d). Virulence
10. Region C is responsible for
- a). Tumour induction
c). Conjugation
- b). Replication
d). Virulence
11. Region D is responsible for
- a). Tumour induction
c). Conjugation
- b). Replication
d). Virulence
12. The gene responsible for shooty locus in T-DNA region is
- a). tms
c). tmr
- b). tms2
d). tms and tms2
13. The gene responsible for rooty locus in T-DNA region is
- a). tms
c). tmr
- b). tms2
d). None of the above
14. The chemical mediated (PEG) transfer is proposed by.....
- a). Krens**
c).
- b).
d). None of the above
15. The optimum concentration of PEG for DNA transfer is.....
- a). 15-25%**
c). 10%
- b). 30-40%
d). None of the above
16. The microinjection method was introduced by.....
- a). Crossway and Reich**
c). Klein
- b). Fromm
d). Xu
17. The electroporation method was introduced by.....
- a). Crossway and Reich
c). Klein
- b). Fromm**
d). Xu
18. The particle gun for gene transfer was introduced by.....
- a). Crossway and Reich
c). Klein
- b). Fromm
d). Xu
19. The sonication method was introduced by.....
- a). Crossway and Reich
c). Klein
- b). Fromm
d). Xu

Additional reading...

http://www.biotechnology4u.com/plant_biotechnology_gene_transfermethods_plants.html

<http://depts.washington.edu/agro/>

<http://www.ejbiotechnology.info/content/vol1/issue3/full/1/bip/>

<http://arabidopsis.info/students/agrobacterium/>

Transgenic plants and their applications

The genetic manipulation of plant protoplasts by direct gene transfer has clearly come of age after a long gestation period. The major limiting factor to the practical application of gene transfer is that protoplasts isolated from many crop species are recalcitrant to regeneration. However, the great successes achieved in the past five years in the field of gene transfer remain as boosters for the future. Some success stories related to the production of transgenic plants are described below.

The major successes have been achieved in the transfer of:

1. Genes for herbicide tolerance.
2. Insect tolerant genes.
3. Coat protein genes for cross protection.
4. Genes responsible for certain antisense RNA and
5. Reporter genes.

1. Transfer of genes for herbicide tolerance

Success has been made in the incorporation of genes conferring tolerance to herbicides. The transgenic plants thus produced show expression of foreign genes resulting in a higher level of herbicide tolerance. The best example is the work of **Shah** and his co-workers. In 1986, they isolated a cDNA clone encoding an enzyme 5-enolpyruvyl-shikimate phosphate (EPSP) synthase from a glyphosate tolerant *Petunia hybrida* cell line. This cell line over produced the enzyme to the tune of 20 times more. The chimeric EPSP synthase gene was constructed with the use of the cauliflower mosaic virus 35 promoter and introduced into the non-tolerant *Petunia* cell lines. The calli from transformed cell lines showed tolerance to glyphosate and the plants regenerated from the calli showed tolerance to the herbicide whereas the control plants died after spraying the herbicide.

In 1987, **De Block** and his co-workers transferred a gene conferring resistance to bialaphos and phosphinotricin called bar gene isolated from *Streptomyces hygroscopicus*, into tobacco, tomato and potato. This gene encodes for an enzyme, phosphinotricin acetyltransferase which prevents toxicity due to phosphinotricin. This gene has been transferred to tobacco, tomato and potato with the help of 35 S promoter of CaMV. The transformed plants showed high levels of resistance against field dose applications of the bialaphos and phosphinotricin. These results, pave the way to engineer resistance to various herbicides into major crops.

2. Expression of Insect tolerance in transgenic plants

Bacillus thuringiensis is a bacterium that produces proteinaceous crystals during sporulation. These crystal proteins have insecticidal properties especially to Lepidopteran insects. The use of *Bacillus thuringiensis* as a microbial insecticide offers advantages over chemical control agents in that the species-specific action of its insecticidal crystal proteins (ICPs) makes it harmless to non-target insects, to vertebrates, to the environment and the user. In 1987, **Fischhoff** and his colleagues constructed chimeric genes containing the CaMV 35 S promoter and the *B. thuringiensis* crystal protein coding sequences. The cloned *B. thuringiensis* gene has been introduced into tomato and tobacco and the transgenic plants thus produced show an increased level of resistance to Lepidopteran insects. The larvae fed on transgenic plants were killed within 48 hours and there was little evidence of feeding damage to leaves of transformants. Thus the introduction of toxin genes into plants seems to be a practical approach for providing protection against certain insect pests.

3. Expression of coat protein genes for virus protection

In agriculture cross-protection is a common practice to protect the plants from viruses and the coat protein of viruses have an important role in systemic cross protection. **Abel** and his coworkers introduced a chimeric gene containing a cloned cDNA of the coat protein (CP) gene of TMV into tobacco cells on a Ti plasmid of *A. tumefaciens* from which tumour inducing genes have been removed. Plants regenerated from transformed cells expressed TMV mRNA and CP as a nuclear trait. Seedlings from self fertilized transgenic plants were inoculated with TMV and observed for development of disease symptoms. The seedlings that expressed the CP gene showed delayed symptom development and 10-60 per cent of the transgenic plants failed to develop symptoms. This approach would be useful to develop lines with resistance to viruses where resistant varieties have been difficult to develop through conventional plant breeding.

4. Expression of Antisense RNA in transgenic plants

Antisense RNA is a occurs naturally in several organisms to control gene expression. It can inhibit expression of a gene by preventing ribosome binding, obstructing transport of mRNA from nucleus, and increasing mRNA degradation. **Rottstein** and his co-workers in 1987 demonstrated the inhibition of the expression of the nopaline synthase (NOS) gene in tobacco. The transgenic plant having the NOS gene was transferred with a NOS antisense gene construct with CaMV 35 S promoter. The transformed plants were analysed for NOS

activity and the enzyme activity varied depending on the tissue used. This mechanism can be a viable tool if the plants are transformed with antisense genes for the expression of various undesirable characters.

5. Expression of Reporter genes in plants

Though several selectable markers and reporter genes are available for studying gene expression, studies are in progress to develop a simple and viable system for studying gene expression. The luciferase gene from firefly (*Photinus pyralis*) is a novel tool for this purpose. This gene encodes an enzyme that catalyses the light producing ATP-dependent oxidation of luciferin. In 1986, **Ow** and his co-workers introduced the luciferase gene into tobacco. The transgenic plants showed the expression of the luciferase gene by producing light when watered with the substrate luciferin. This reporter gene system provides a simple tool for rapid screening of large numbers of transgenic plants.

Points to be considered in all gene transfer programmes

1. Effective systems for the selection of transformed cells are essential when more complex traits are handled.
2. Expression of a particular gene in the transformed cell depends on its position in the host genome. This warrants further studies on the position effects of transferred genes and their expression.
3. Though efficient gene transfer methods are available the major remaining barrier is the limited range of plants that can be regenerated from transformable cells. So efficient regeneration systems for the crop species is a must for successful gene transfer.
4. The regulatory mechanism involved in the supply of particular substances required for expression of a particular gene should be explored i.e. whether the supply of the substance is automatically improved because of the new gene or whether other genes involved in the synthesis of the substance have to be amplified.
5. The mechanisms involved in the regulation of particular substances for improved gene expression should be explored.
6. The introduction of new genes into plant cells will require that there be new enzymes which were not present in the cells before. In this case, alterations in the entire plants metabolism should thoroughly be studied.
7. Loss of expression of the alien gene can also happen after time. Studies should be done to know about the stable expression and inheritance of the gene concerned.

8. Before attempting a gene transfer, the molecular aspects of the gene concerned should be explored and the need for the gene and its desirability can be assessed.

9. The problems associated with the stable expression of a foreign gene in crop plants should be examined. This will facilitate finding ways and means to alter the temporal and spatial expression of the particular gene.

Applications of transgenic plants

Genetic engineering and GM crops

Over the last 30 years, the field of genetic engineering has developed rapidly due to the greater understanding of deoxyribonucleic acid (DNA) as the chemical double helix code from which genes are made. The term genetic engineering is used to describe the process by which the genetic makeup of an organism can be altered using “recombinant DNA technology.” This involves the use of laboratory tools to insert, alter, or cut out pieces of DNA that contain one or more genes of interest.

Developing plant varieties expressing good agronomic characteristics is the ultimate goal of plant breeders. With conventional plant breeding, however, there is little or no guarantee of obtaining any particular gene combination from the millions of crosses generated. Undesirable genes can be transferred along with desirable genes; or, while one desirable gene is gained, another is lost because the genes of both parents are mixed together and re-assorted more or less randomly in the offspring. These problems limit the improvements that plant breeders can achieve.

In contrast, genetic engineering allows the direct transfer of one or just a few genes of interest, between either closely or distantly related organisms to obtain the desired agronomic trait (Figure 1). Not all genetic engineering techniques involve inserting DNA from other organisms. Plants may also be modified by removing or switching off their own particular genes.

Figure 1: Comparing conventional breeding and genetic engineering (The dots represent genes, with white representing the gene of interest)

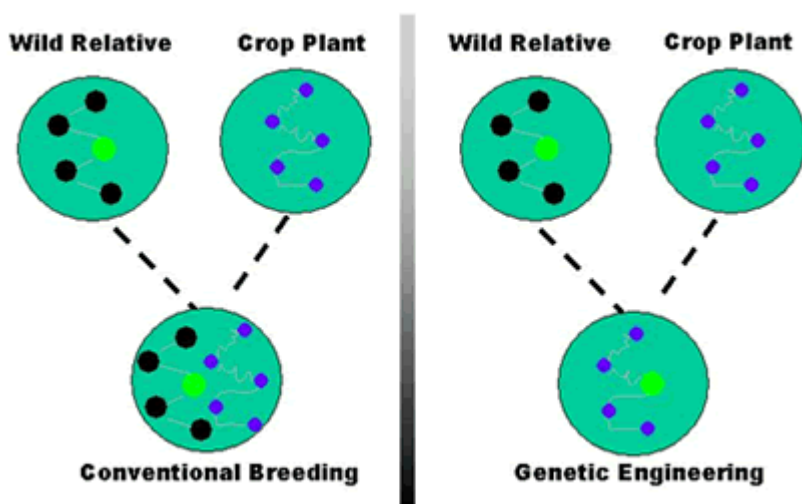

Source: ISAAA Mentor's Kit, 2003.

Table 1: Conventional Breeding vs. Genetic Engineering	
Conventional Breeding	Genetic Engineering
<ul style="list-style-type: none"> • Limited to exchanges between the same or very closely related species • Little or no guarantee of any particular gene combination from the million of crosses generated • Undesirable genes can be transferred along with desirable genes • Takes a long time to achieve desired results 	<ul style="list-style-type: none"> • Allows the direct transfer of one or just a few genes, between either closely or distantly related organisms • Crop improvement can be achieved in a shorter time compared to conventional breeding • Allows plants to be modified by removing or switching off particular genes

Source: ISAAA Mentor's Kit, 2003.

“Genes are molecules of DNA that code for distinct traits or characteristics. For instance, a particular gene sequence is responsible for the color of a flower or a plant’s ability to fight a disease or thrive in extreme environment.”

Nature’s own genetic engineer

The “sharing” of DNA among living forms is well documented as a natural phenomenon. For thousands of years, genes have moved from one organism to another. For example, *Agrobacterium tumefaciens*, a soil bacterium known as ‘nature’s own genetic engineer’, has the natural ability to genetically engineer plants. It causes crown gall disease in a wide range of broad-leaved plants, such as apple, pear, peach, cherry, almond, raspberry, and roses. The disease gains its name from the large tumor-like swellings (galls) that typically occur at the crown of the plant, just above soil level. Basically, the bacterium transfers part

of its DNA to the plant, and this DNA integrates into the plant's genome, causing the production of tumors and associated changes in plant metabolism.

Application of genetic engineering in crop production

Genetic engineering techniques are used only when all other techniques have been exhausted, i.e. when the trait to be introduced is not present in the germplasm of the crop; the trait is very difficult to improve by conventional breeding methods; and when it will take a very long time to introduce and/or improve such trait in the crop by conventional breeding methods (see Figure 2). Crops developed through genetic engineering are commonly known as transgenic crops or genetically modified (GM) crops.

Modern plant breeding is a multi-disciplinary and coordinated process where a large number of tools and elements of conventional breeding techniques, bioinformatics, molecular genetics, molecular biology, and genetic engineering are utilized and integrated.

Figure 2: Modern Plant Breeding

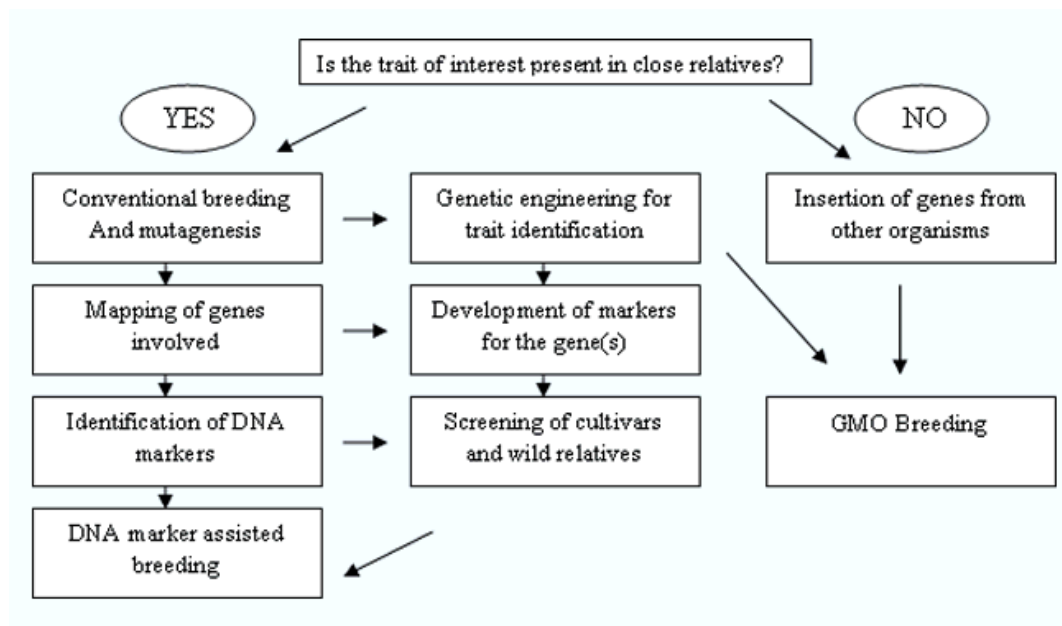

Source: DANIDA, 2002.

Development of transgenic crops

Although there are many diverse and complex techniques involved in genetic engineering, its basic principles are reasonably simple. There are five major steps in the development of a genetically engineered crop. But for every step, it is very important to know the biochemical and physiological mechanisms of action, regulation of gene expression, and

safety of the gene and the gene product to be utilized. Even before a genetically engineered crop is made available for commercial use, it has to pass through rigorous safety and risk assessment procedures.

The first step is the extraction of DNA from the organism known to have the trait of interest. The second step is gene cloning, which will isolate the gene of interest from the entire extracted DNA, followed by mass-production of the cloned gene in a host cell. Once it is cloned, the gene of interest is designed and packaged so that it can be controlled and properly expressed once inside the host plant. The modified gene will then be mass-produced in a host cell in order to make thousands of copies. When the gene package is ready, it can then be introduced into the cells of the plant being modified through a process called transformation. The most common methods used to introduce the gene package into plant cells include biolistic transformation (using a gene gun) or Agrobacterium-mediated transformation. Once the inserted gene is stable, inherited, and expressed in subsequent generations, then the plant is considered a transgenic. Backcross breeding is the final step in the genetic engineering process, where the transgenic crop is bred and selected in order to obtain high quality plants that express the inserted gene in a desired manner.

The length of time in developing transgenic plant depends upon the gene, crop species, available resources, and regulatory approval. It may take 6-15 years before a new transgenic hybrid is ready for commercial release.

Commercially available crops improved through genetic engineering

There has been a consistent increase in the global area planted to transgenic crops from 1996 to 2005. About 90 M ha was planted in 2005 to transgenic crops with high market value, such as herbicide tolerant soybean, maize, cotton, and canola; insect resistant maize, cotton, potato, and rice; and virus resistant squash and papaya. With genetic engineering, more than one trait can be incorporated into a plant. Transgenic crops with combined traits are also available commercially. These include herbicide tolerant and insect resistant maize and cotton.

New and future initiatives in crop genetic engineering

To date, commercial GM crops have delivered benefits in crop production, but there are also a number of products in the pipeline which will make more direct contributions to food

quality, environmental benefits, pharmaceutical production, and non-food crops. Examples of these products include: rice with higher levels of iron and b-carotene (an important micronutrient which is converted to vitamin A in the body); long life banana that ripens faster on the tree and can therefore be harvested earlier; maize with improved feed value; tomatoes with high levels of flavonols, which are powerful antioxidants; drought tolerant maize; maize with improved phosphorus availability; arsenic-tolerant plants; edible vaccines from fruit and vegetables; and low lignin trees for paper making.

Genetically Modified Crops

Global agriculture finds itself engrossed in a heated debate over genetically modified (GM) crops. This debate, which features science, economics, politics, and even religion, is taking place almost everywhere. It is going on in research labs, corporate boardrooms, legislative chambers, newspaper editorial offices, religious institutions, schools, supermarkets, coffee shops, and even in private homes. What is all the fuss



about and why do people feel so strongly about this issue? This Pocket “K” attempts to shed light on the controversy by addressing several basic questions about GM crops.

Why make GM crops?

Traditionally, a plant breeder tries to exchange genes between two plants to produce offspring that have desired traits. This is done by transferring the male (pollen) of one plant to the female organ of another.

This cross breeding, however, is limited to exchanges between the same or very closely related species. It can also take a long time to achieve desired results and frequently, characteristics of interest do not exist in any related species.

GM technology enables plant breeders to bring together in one plant useful genes from a wide range of living sources, not just from within the crop species or from closely related plants. This powerful tool allows plant breeders to do faster what they have been doing for years—generate superior plant varieties—although it expands the possibilities beyond the limits imposed by conventional plant breeding.

Who produces GM crops?

Most of the research on GM crops has been carried out in developed countries, mainly in North America and Western Europe.

Recently, however, many developing countries have also established the capacity for genetic engineering.

In developed countries, the new life sciences companies have dominated the application of GM technology to agriculture. These include Bayer CropScience, Dow AgroSciences, DuPont/Pioneer, Monsanto, and Syngenta.

What is a GM crop?

A GM or transgenic crop is a plant that has a novel combination of genetic material obtained through the use of modern biotechnology.

For example, a GM crop can contain a gene(s) that has been artificially inserted instead of the plant acquiring it through pollination.

The resulting plant is said to be “genetically modified” although in reality all crops have been “genetically modified” from their original wild state by domestication, selection, and controlled breeding over long periods of time.



Where are GM crops currently grown?



In 1994, Calgene’s delayed-ripening tomato (Flavr-Savr™) became the first genetically modified food crop to be produced and consumed in an industrialized country. Since then several countries have contributed to more than a 47-fold increase in the global area of transgenic crops.

The area planted to GM crops shot up from 1.7 million hectares in 1996 to 90 million hectares in 2005, with an increasing proportion grown by developing countries. In 2005, there were 14 biotech mega-countries, growing 50,000 hectares or more, 10 developing countries and four industrial countries; they were, in order of hectarage, USA, Argentina,

Brazil, Canada, China, Paraguay, India, South Africa, Uruguay, Australia, Mexico, Romania, Philippines, and Spain (James, 2005).

What are the potential benefits of GM plants?

In the developed world, there is clear evidence that the use of GM crops has resulted in significant benefits. These include:

- Higher crop yields
- Reduced farm costs
- Increased farm profit
- Improvement in health and the environment

These “first generation” crops have proven their ability to lower farm-level production costs. Now, research is focused on “second-generation” GM crops that will feature increased nutritional and/or industrial traits. These crops will have more direct benefits to consumers.

Examples include:

- Rice enriched with iron and vitamin A
- Potatoes with higher starch content
- Edible vaccines in maize and potatoes
- Maize varieties able to grow in poor conditions
- Healthier oils from soybean and canola

How are GM crops made?

GM crops are made through a process known as genetic engineering. Genes of commercial interest are transferred from one organism to another. Two primary methods currently exist for introducing transgenes into plant genomes.

The first involves a device called a ‘gene gun.’ The DNA to be introduced into the plant cells is coated onto tiny particles. These particles are then physically shot onto plant cells. Some of the DNA comes off and is incorporated into the DNA of the recipient plant. The second method uses a bacterium to introduce the gene(s) of interest into the plant DNA.

Are GM crops appropriate for developing countries?



While most of the debate over transgenic crops has taken place mainly in the developed nations in the North, the South stands to benefit from any technology that can increase food production, lower food prices, and improve food quality.

In countries where there is often not enough food to go around and where food prices directly affect the incomes of majority of the population, the potential benefits of GM crops cannot be ignored. It is true that nutritionally enhanced foods may not be a necessity in developed countries but they could play a key role in helping to alleviate malnutrition in developing countries.

Although the potential benefits of GM crops are large in developing countries, they would require some investments. Most developing countries lack the scientific capacity to assess the biosafety of GM crops, the economic expertise to evaluate their worth, the regulatory capacity to implement guidelines for safe deployment, and the legal systems to enforce and punish transgressions in law. Fortunately, several organizations are working to build local capacity to manage the acquisition, deployment, and monitoring of GM crops.

What are the potential risks of GM plants?

With every new emerging technology, there are potential risks. These include:

- The danger of unintentionally introducing allergens and other antinutrition factors in foods
- The likelihood of transgenes escaping from cultivated crops into wild relatives
- The potential for pests to evolve resistance to the toxins produced by GM crops
- The risk of these toxins affecting nontarget organisms.

Where legislation and regulatory institutions are in place, there are elaborate steps to precisely avoid or mitigate these risks. It is the obligation of the technology innovators (i.e., scientists), producers, and the government to assure the public of the safety of the novel foods that they offer as well as their benign effect on the environment.

There are also those risks that are neither caused nor preventable by the technology itself. An example of this type of risk is the further widening of the economic gap between developed countries (technology users) versus developing countries (nonusers). These

risks, however, can be managed by developing technologies tailor made for the needs of the poor and by instituting measures so that the poor will have access to the new technologies.

Plant products of biotechnology

Plant products of biotechnology have been available in the market for some time now. These modified crops look like their traditional counterparts, but they possess special characteristics that make them better.

These crops benefit both farmers and consumers. Farmers gain higher crop yields and have increased flexibility in management practices, while consumers have “healthier crops” (i.e., crops grown with fewer pesticides and/or with healthier nutritional characteristics).

Plant products of biotechnology approved for food use have been modified to contain traits such as:

- Disease resistance
- Herbicide tolerance
- Altered nutritional profile
- Enhanced storage life

Biotech Soybean

Soybean is the oil crop of greatest economic relevance in the world. Its beans contain proportionally more essential amino acids than meat, thus making it one of the most important food crops today.



Herbicide-tolerant soybean

Herbicide-tolerant soybean varieties contain a gene that provides resistance to one of two broad-spectrum, environmentally benign herbicides.

This modified soybean provides better weed control and reduces crop injury. It also improves farm efficiency by optimizing yield, using arable land more efficiently, saving time for the farmer, and increasing the flexibility of crop rotation. It also encourages the adoption of no-till farming-an important part of soil conservation practice.

These varieties are the same as other soybeans in nutrition, composition, and the way they are processed into food and feed. * *Argentina, Australia, Brazil, Canada, Czech Republic, EU, Japan, Korea, Mexico, Philippines, Russia, South Africa, Switzerland, Taiwan, UK, US, and Uruguay.*

Oleic acid soybean

This modified soybean contains high levels of oleic acid, a monounsaturated fat. According to health nutritionists, monounsaturated fats are considered “good” fats, compared with saturated fats found in beef, pork, hard cheeses, and other dairy products.

Oil processed from these varieties is similar to that of peanut and olive oils. Conventional soybeans have an oleic acid content of 24%. These new varieties have an oleic acid content that exceeds 80%. * *Australia, Canada, Japan, and the US.*

Examples of plant products of biotechnology

Product	Trait
Canola	Herbicide tolerance
Canola	Modified fatty acid content
Cotton	Insect resistance
Cotton	Herbicide tolerance
Flax, Linseed	Insect resistance & herbicide tolerance
Lentil	Herbicide tolerance
Maize	Herbicide tolerance
Maize	Insect resistance & herbicide tolerance
Maize	Herbicide tolerance & male sterility
Maize	Herbicide tolerance & fertility restored
Maize	Modified amino acid content
Melon	Delayed ripening
Papaya	Virus resistance
Potato	Insect resistance
Potato	Insect & virus resistance
Rice	Herbicide tolerance
Soybean	Herbicide tolerance

Soybean	Modified fatty acid content
Squash	Virus resistance
Sugar Beet	Herbicide tolerance
Tomato	Delayed ripening
Tomato	Insect resistance
Wheat	Herbicide tolerance
Wheat	Herbicide tolerance

*Source: <http://www.agbios.com>

Biotech Corn

Corn is one of the three most important grains of the world.



Herbicide-tolerant corn

These corn varieties work in a similar manner to herbicide-tolerant soybean. They allow growers better flexibility in using certain herbicides to control weeds that can damage crops. * *Argentina, Australia, Canada, China, European Union (EU), Japan, Korea, Philippines, South Africa, Switzerland, and the US.*

Insect-resistant corn

This modified corn contains a built-in insecticidal protein from a naturally occurring soil microorganism (Bt) that gives corn plants season-long protection from corn borers. The Bt protein has been used safely as an organic insect control agent for over 40 years. This means most farmers do not have to spray insecticide to protect corn from harmful pests, which can cause significant damage and yield loss in many areas. Bt corn also reduces toxin contamination arising from fungal attack on the damaged grain. * *Argentina, Australia, Canada, China, EU, Japan, Korea, Mexico, Philippines, Russia, South Africa, Switzerland, Taiwan, UK, US, and Uruguay.*

Biotech Canola

Canola is a genetic variation of rapeseed and was developed by Canadian plant breeders specifically for its nutritional qualities, particularly its low level of saturated fat.



Herbicide-tolerant canola

Herbicide-tolerant canola works in a manner similar to other such crops. For benefits, see herbicide-tolerant soybean. * *Australia, Canada, EU, Japan, Philippines, and the US.*

High laurate canola

These canola varieties contain high levels of laurate. Oil processed from these novel varieties is similar to coconut and palm oils.

This new canola oil is being sold to the food industry for use in chocolate candy coatings, coffee whiteners, icings, frostings, and whipped toppings. Benefits extend even to the cosmetics industry. * *Canada and the US.*

Oleic acid canola

This new type of canola contains high levels of oleic acid. For benefits, see oleic acid soybean. * *Canada.*

Biotech Cotton

Herbicide-tolerant cotton

This cotton works in a manner similar to other such crops. For benefits, see herbicide-tolerant soybean. * *Argentina, Australia, Canada, Japan, Mexico, Philippines, and the US.*



Insect-resistant cotton

This modified cotton works in a manner similar to insect-resistant corn. It contains a protein that provides the plant with season-long protection from budworms and bollworms. The need for additional insecticide applications for these pests is reduced or eliminated. * *Argentina, Australia, Brazil, Canada, China, Japan, Mexico, Philippines, South Africa, and the US. (Approved for planting in India.)*

Dominant GM crops in the World, 2005	
Crops	M/ha (million hectares)
Herbicide tolerant soybean	54.4
Bt maize	11.3
Bt/Herbicide tolerant maize	6.5
Bt cotton	4.9
Herbicide tolerant canola	4.6
Bt/Herbicide tolerant cotton	3.6
Herbicide tolerant maize	3.4

Herbicide tolerant cotton	1.3
Total	90.0
*Million hectares James, C. 2005. Global Status of Commercialized Biotech/GM Crops: 2005. ISAAA Briefs No. 34. ISAAA: Ithaca, NY.	

Biotech Potato

Insect-resistant potato

This biotech potato works like insect-resistant corn. It contains a protein that provides the plant with built-in protection from the Colorado potato beetle. Thus, this potato needs no additional protection for this pest, benefiting farmers, consumers, and the environment. **Australia, Canada, Japan, Philippines, and the US.*



Virus-resistant potato

Several potato varieties have been modified to resist potato leafroll virus (PLRV) and potato virus Y (PVY). In the same way that people get inoculations to prevent disease, these potato varieties are protected through biotechnology from certain viruses. Furthermore, virus resistance often results in reduced insecticide use, which is needed to control insect vectors that transmit viruses. **Australia, Canada, Philippines, and the US.*

Biotech Squash

Virus-resistant squash

A biotech yellow crookneck squash is now able to resist watermelon mosaic virus (WMV) and zucchini yellow mosaic virus (ZYMV). These new varieties contain the coat protein genes of both viruses. This biotech approach bypasses aphid control, which may reduce or eliminate the use of insecticides. **Canada and US.*



Biotech Tomato

Delayed-ripening tomato

The delayed-ripening tomato became the first genetically modified food crop to be produced in a developed country. These tomato



varieties have extended shelf life. They contain a gene that slows the natural softening process that accompanies ripening.

These tomatoes spend more days on the vine than other tomatoes, thus resulting in better flavor. Furthermore, the longer shelf life has commercial advantages in harvesting and shipping that can reduce the costs of production, **Canada, Japan, Mexico, and the US.*

Biotech papaya

Virus-resistant papaya

This Hawaiian-developed papaya contains a viral gene that encodes for the coat protein of papaya ringspot virus (PRSV). This protein provides the papaya plant with built-in protection against PRSV. This biotech papaya works in a manner similar to virus resistant potato.



Questions

1. Bar gene conferring resistance to bialaphos and phosphinotricin was isolated from.....

- a). ***Streptomyces hygrosopicers***
- b). *Bacillus thuringiensis*
- c). *Bacillus subtilis*
- d). None of the above

2. Flavr-Savr™ is the GM variety of

- a). **Tomato**
- b). Potato
- c). Soyabean
- d). Aonla

3. Flavr-Savr™, the GM variety of tomato has property

- a). **Delayed ripening**
- b). Resistance to fruit borer
- c). Resistant to leaf miner
- d). None of the above

4. The potential benefits of GM crops are

- a). Higher crop yields
- b). Reduced farm costs
- c). Increased farm profit
- d). **All the above**

5. The potential hazards of GM crops are

- a). The danger of unintentionally introducing allergens and other antinutrition factors in foods
- b). The likelihood of transgenes escaping from cultivated crops into wild relatives
- c). The potential for pests to evolve resistance to the toxins produced by GM crops
- d). **All the above**

Blotting techniques

Blotting is the technique in which nucleic acids or proteins are immobilized onto a solid support generally nylon or nitrocellulose membranes. Blotting of nucleic acid is the central technique for hybridization studies. Nucleic acid labeling and hybridization on membranes have formed the basis for a range of experimental techniques involving understanding of gene expression, organization, etc.

Identifying and measuring specific proteins in complex biological mixtures, such as blood, have long been important goals in scientific and diagnostic practice. More recently the identification of abnormal genes in genomic DNA has become increasingly important in clinical research and genetic counseling. Blotting techniques are used to identify unique proteins and nucleic acid sequences. They have been developed to be highly specific and sensitive and have become important tools in both molecular biology and clinical research.

General principle

The blotting methods are fairly simple and usually consist of four separate steps: electrophoretic separation of protein or of nucleic acid fragments in the sample; transfer to and immobilization on paper support; binding of analytical probe to target molecule on paper; and visualization of bound probe. Molecules in a sample are first separated by electrophoresis and then transferred on to an easily handled support medium or membrane. This immobilizes the protein or DNA fragments, provides a faithful replica of the original separation, and facilitates subsequent biochemical analysis. After being transferred to the support medium the immobilized protein or nucleic acid fragment is localized by the use of probes, such as antibodies or DNA, that specifically bind to the molecule of interest. Finally, the position of the probe that is bound to the immobilized target molecule is visualized usually by autoradiography. Three main blotting techniques have been developed and are commonly called Southern, northern and western blotting.

Southern blot

Southern blot is a method used to check for the presence of a DNA sequence in a DNA sample. The method is named after its inventor, the British biologist Edwin Southern.

The procedure for Southern blot technique is as detailed below:

- Restriction endonucleases are used to cut high-molecular-weight DNA strands into smaller fragments, which are then electrophoresed on an agarose gel to separate them by size.
- If the DNA fragments are larger than 15 kb, then prior to blotting, the gel may be treated with an acid, such as dilute HCl, which depurinates the DNA fragments, breaking the DNA into smaller pieces, thus allowing more efficient transfer from the gel to membrane.
- If alkaline transfer methods are used, the DNA gel is placed into an alkaline solution (containing NaOH) to denature the double-stranded DNA. The denaturation in an alkaline environment may improve binding of the negatively charged DNA to a positively charged membrane, separating it into single DNA strands for later hybridization to the probe and destroys any residual RNA that may still be present in the DNA.
- A sheet of nitrocellulose (or nylon) membrane is placed on top of (or below, depending on the direction of the transfer) the gel. Pressure is applied evenly to the gel (either using suction, or by placing a stack of paper towels and a weight on top of the membrane and gel), to ensure good and even contact between gel and membrane. Buffer transfer by capillary action from a region of high water potential to a region of low water potential (usually filter paper and paper tissues) is used to move the DNA from the gel on to the membrane; ion exchange interactions bind the DNA to the membrane due to the negative charge of the DNA and positive charge of the membrane.
- The membrane is then baked in a vacuum or regular oven at 80 °C for 2 hours or exposed to ultraviolet radiation (nylon membrane) to permanently attach the transferred DNA to the membrane.
- The membrane is then exposed to a hybridization probe—a single DNA fragment with a specific sequence whose presence in the target DNA is to be determined. The probe DNA is labelled so that it can be detected, usually by incorporating radioactivity or tagging the molecule with a fluorescent or chromogenic dye.
- After hybridization, excess probe is washed from the membrane and the pattern of hybridization is visualized on X-ray film by autoradiography in the case of a radioactive or fluorescent probe, or by development of colour on the membrane if a chromogenic detection method is used.

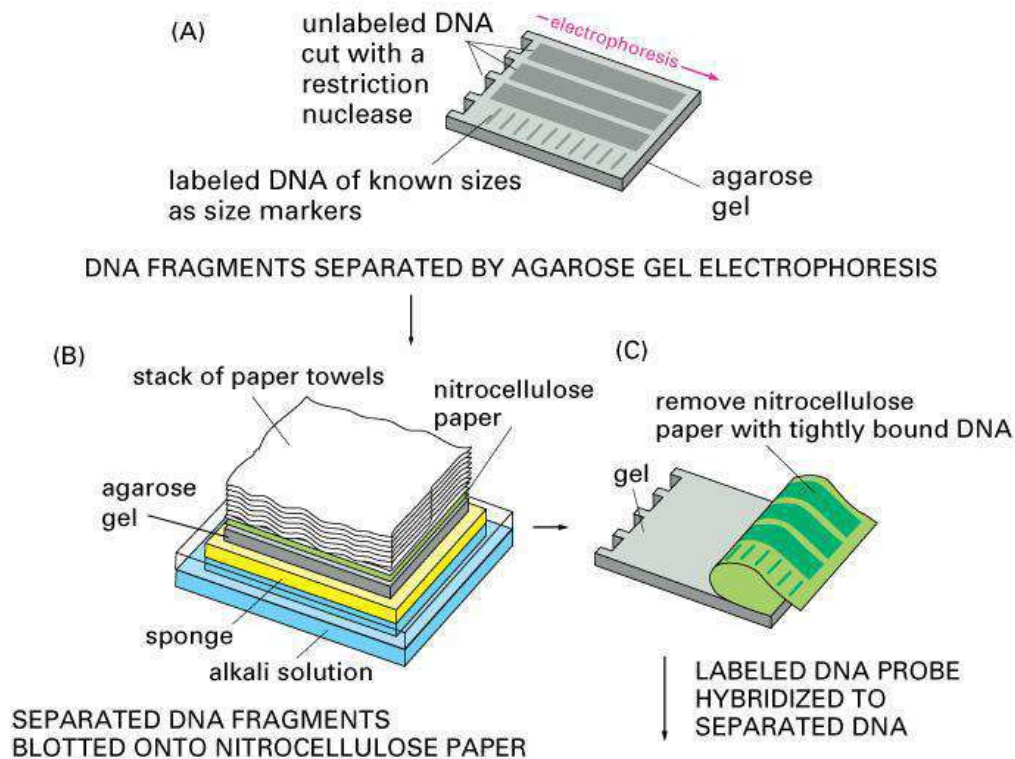

Hybridization of the probe to a specific DNA fragment on the filter membrane indicates that this fragment contains DNA sequence that is complementary to the probe. The transfer step of the DNA from the electrophoresis gel to a membrane permits easy binding of the labeled hybridization probe to the size-fractionated DNA. Southern blots performed with restriction enzyme-digested genomic DNA may be used to determine the number of sequences (e.g., gene copies) in a genome. A probe that hybridizes only to a single DNA segment that has not been cut by the restriction enzyme will produce a single band on a Southern blot, whereas multiple bands will likely be observed when the probe hybridizes to several highly similar sequences (e.g., those that may be the result of sequence duplication). Modification of the hybridization conditions (ie, increasing the hybridization temperature or decreasing salt concentration) may be used to increase specificity and decrease hybridization of the probe to sequences that are less than 100% similar.

Northern blot

The **northern blot** technique is used to study gene expression by detection of RNA (or isolated mRNA) in a sample. With northern blotting it is possible to observe cellular control over structure and function by determining the particular gene expression levels during differentiation,

morphogenesis, as well as abnormal or diseased conditions. This technique was developed in 1977 by James Alwine, David Kemp and George Stark at Stanford University. Northern blotting takes its name from its similarity to the first blotting technique, the Southern blot. The major difference is that RNA, rather than DNA, is analyzed in the northern blot.

Procedure

The blotting procedure starts with extraction of total RNA from a homogenized tissue sample. The mRNA can then be isolated through the use of oligo (dT) cellulose chromatography to maintain only those RNAs with a poly(A) tail. RNA samples are then separated by gel electrophoresis. A nylon membrane with a positive charge is the most effective for use in northern blotting since the negatively charged nucleic acids have a high affinity for them. The transfer buffer used for the blotting usually contains formamide because it lowers the annealing temperature of the probe-RNA interaction preventing RNA degradation by high temperatures. Once the RNA has been transferred to the membrane it is immobilized through covalent linkage to the membrane by UV light or heat. After a probe has been labeled, it is hybridized to the RNA on the membrane. The membrane is washed to ensure that the probe has bound specifically. The hybrid signals are then detected by X-ray film and can be quantified by densitometry.

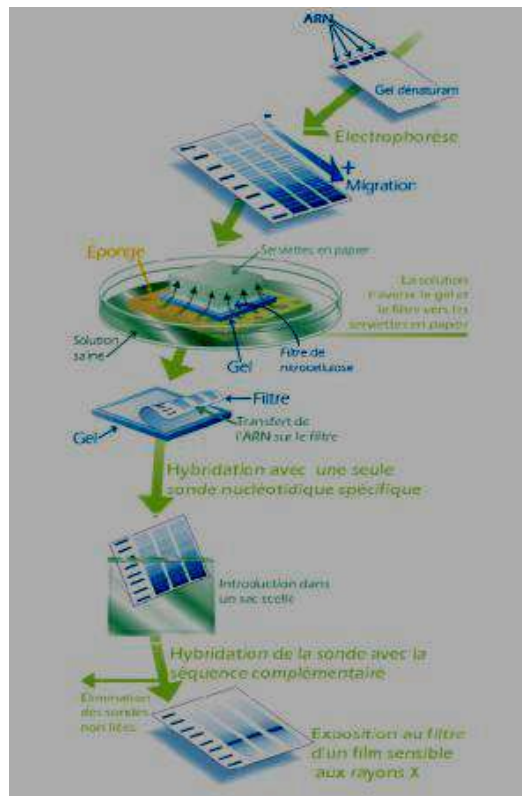

Applications

Northern blotting allows in observing a particular gene's expression pattern between tissues, organs, developmental stages, environmental stress levels, pathogen infection. The technique has been used to show over expression of oncogenes and down regulation of tumor-suppressor genes in cancerous cells when compared to 'normal' tissue, as well as the gene expression in the rejection of transplanted organs. If an up regulated gene is observed by an abundance of mRNA on the northern blot the sample can then be sequenced to determine if the gene is known to researchers or if it is a novel finding. The expression patterns obtained under given conditions can provide insight into the function of that gene. Since the RNA is first separated by size, if only one probe type is used variance in the level of each band on the membrane can provide insight into the size of the product, suggesting alternative splice products of the same gene or repetitive sequence motifs. The variance in size of a gene product can also indicate deletions or errors in transcript processing, by altering the probe target used along the known sequence it is possible to determine which region of the RNA is missing.

Advantages & disadvantages

Analysis of gene expression can be done by several different methods including RT-PCR, RNase protection assays, microarrays, serial analysis of gene expression (SAGE), as well as northern blotting. Microarrays are quite commonly used and are usually consistent with data obtained from northern blots, however at times northern blotting is able to detect small changes in gene expression that microarrays cannot. The advantage that microarrays have over northern blots is that thousands of genes can be visualized at a time while northern blotting is usually looking at one or a small number of genes. A problem in northern blotting is often sample degradation by RNases (both endogenous to the sample and through environmental contamination) which can be avoided by proper sterilization of glassware and the use of RNase inhibitors such as DEPC (diethylpyrocarbonate). The chemicals used in most northern blots can be a risk to the researcher, since formaldehyde, radioactive material; ethidium bromide, DEPC, and UV light are all harmful under certain exposures. Compared to RT-PCR northern blotting has a low sensitivity but it also has a high specificity which is important to reduce false positive results. The advantages of using northern blotting include the detection of RNA size, the observation of alternate splice products, the use of probes with partial homology, the quality and quantity of RNA can be measured on the gel prior to blotting, and the membranes can be stored and reprobbed for years after blotting.

Reverse northern blot

A variant of the procedure known as the reverse northern blot is occasionally used. In this procedure, the substrate nucleic acid (that is affixed to the membrane) is a collection of isolated DNA fragments, and the probe is RNA extracted from a tissue and radioactively labelled. The use of DNA microarrays that have come into widespread use in the late 1990s and early 2000s is more akin to the reverse procedure, in that they involve the use of isolated DNA fragments affixed to a substrate, and hybridization with a probe made from cellular RNA. Thus the reverse procedure, though originally uncommon, enabled northern analysis to evolve into gene expression profiling, in which many (possibly all) of the genes in an organism may have their expression monitored.

Western blot

The **western blot** (alternatively, **immunoblot**) is used to detect specific proteins in a given sample of tissue homogenate or extract. The method originated from the laboratory of George Stark at Stanford. The name **western blot** was given to the technique by W. Neal Burnette.

Steps in a western blot

Tissue preparation

Samples may be taken from whole tissue or from cell culture. In most cases, solid tissues are first broken down mechanically using a blender (for larger sample volumes), homogenizer (smaller volumes) or sonication. Assorted detergents, salts and buffers may be employed to encourage lysis of cells and to solubilize proteins. Protease and phosphatase inhibitors are often added to prevent the digestion of the sample by its own enzymes. Tissue preparation is often done at cold temperatures to avoid protein denaturing. A combination of biochemical and mechanical techniques, including various types of filtration and centrifugation can be used to separate different cell compartments and organelles.

Gel electrophoresis

The proteins of the sample are separated using gel electrophoresis. Separation of proteins may be by isoelectric point (pI), molecular weight, electric charge or a combination of these factors. SDS-PAGE (SDS polyacrylamide gel electrophoresis) maintains polypeptides in a denatured state once they have been treated with strong reducing agents to remove secondary and tertiary structure and thus allows separation of proteins by their molecular weight. Sampled proteins become covered in the negatively charged SDS and move to the positively charged electrode

through the acrylamide mesh of the gel. Smaller proteins migrate faster through this mesh and the proteins are thus separated according to size. The concentration of acrylamide determines the resolution of the gel - the greater the acrylamide concentration the better the resolution of lower molecular weight proteins. The lower the acrylamide concentration the better the resolution of higher molecular weight proteins. Proteins travel only in one dimension along the gel for most blots.

Samples are loaded into wells in the gel. One lane is usually reserved for a *marker* or *ladder*, a commercially available mixture of proteins having defined molecular weights, typically stained so as to form visible, coloured bands. When voltage is applied along the gel, proteins migrate into it at different speeds. These different rates of advancement separate into *bands* within each lane. It is also possible to use a two-dimensional (2-D) gel which spreads the proteins from a single sample out in two dimensions. Proteins are separated according to isoelectric point (pH at which they have neutral net charge) in the first dimension, and according to their molecular weight in the second dimension.

Transfer

In order to make the proteins accessible to antibody detection, they are moved from within the gel onto a nitrocellulose or polyvinylidene difluoride (PVDF) membrane similar to Southern blot DNA transfer. Another method for transferring the proteins is called electro blotting and uses an electric current to pull proteins from the gel into the PVDF or nitrocellulose membrane. The proteins move from within the gel onto the membrane while maintaining the organization they had within the gel. As a result of this "blotting" process, the proteins are exposed on a thin surface layer for detection. Protein binding is based upon hydrophobic interactions, as well as charged interactions between the membrane and protein. Nitrocellulose membranes are cheaper than PVDF, but are far more fragile and do not stand up well to repeated probings.

The uniformity and overall effectiveness of transfer of protein from the gel to the membrane can be checked by staining the membrane with Coomassie or Ponceau S dyes. Ponceau S is the more common of the two, due to Ponceau S's higher sensitivity and its water solubility makes it easier to subsequently destain and probe the membrane.

Blocking

Since the membrane has been chosen for its ability to bind protein and both antibodies and the target are proteins, steps must be taken to prevent interactions between the membrane and the

antibody used for detection of the target protein. Blocking of non-specific binding is achieved by placing the membrane in a dilute solution of protein - typically Bovine serum albumin (BSA) or non-fat dry milk (both are inexpensive), with a minute percentage of detergent such as Tween 20. The protein in the dilute solution attaches to the membrane in all places where the target proteins have not attached. Thus, when the antibody is added, there is no room on the membrane for it to attach other than on the binding sites of the specific target protein. This reduces "noise" in the final product of the Western blot, leading to clearer results, and eliminates false positives.

Detection

During the detection process the membrane is "probed" for the protein of interest with a modified antibody which is linked to a reporter enzyme, which when exposed to an appropriate substrate drives a colourimetric reaction and produces a colour. For a variety of reasons, this traditionally takes place in a two-step process, although there are now one-step detection methods available for certain applications.

Two step

- Primary antibody

Antibodies are generated when a host species or immune cell culture is exposed to the protein of interest. Normally, this is part of the immune response; whereas here they are harvested and used as sensitive and specific detection tools that bind the protein directly.

After blocking, a dilute solution of primary antibody (generally between 0.5 and 5 micrograms/ml) is incubated with the membrane under gentle agitation. Typically, the solution is composed of buffered saline solution with a small percentage of detergent, and sometimes with powdered milk or BSA. The antibody solution and the membrane can be sealed and incubated together for anywhere from 30 minutes to overnight. It can also be incubated at different temperatures, with warmer temperatures being associated with more binding, both specific (to the target protein, the "signal") and non-specific ("noise").

- Secondary antibody

After rinsing the membrane to remove unbound primary antibody, the membrane is exposed to another antibody, directed at a species-specific portion of the primary antibody. This is known as a secondary antibody, and due to its targeting properties, tends to be referred to as "anti-mouse," "anti-goat," etc. Antibodies come from animal sources (or animal sourced hybridoma cultures); an anti-mouse secondary will bind to just about any mouse-sourced primary antibody.

This allows some cost savings by allowing an entire lab to share a single source of mass-produced antibody, and provides far more consistent results. The secondary antibody is usually linked to biotin or to a reporter enzyme such as alkaline phosphatase or horseradish peroxidase. This means that several secondary antibodies will bind to one primary antibody and enhance the signal.

Most commonly, a horseradish peroxidase-linked secondary is used in conjunction with a chemiluminescent agent, and the reaction product produces luminescence in proportion to the amount of protein. A sensitive sheet of photographic film is placed against the membrane, and exposure to the light from the reaction creates an image of the antibodies bound to the blot. A cheaper but less sensitive approach utilizes a 4-chloronaphthol stain with 1% hydrogen peroxide; reaction of peroxide radicals with 4-chloronaphthol produces a dark brown stain that can be photographed without using specialized photographic film.

As with the ELISPOT and ELISA procedures, the enzyme can be provided with a substrate molecule that will be converted by the enzyme to a colored reaction product that will be visible on the membrane (see the figure below with blue bands).

A third alternative is to use a radioactive label rather than an enzyme coupled to the secondary antibody, such as labeling an antibody-binding protein like *Staphylococcus* Protein A with a radioactive isotope of iodine. Since other methods are safer, quicker and cheaper this method is now rarely used.

One step

Historically, the probing process was performed in two steps because of the relative ease of producing primary and secondary antibodies in separate processes. This gives researchers and corporations huge advantages in terms of flexibility, and adds an amplification step to the detection process. Given the advent of high-throughput protein analysis and lower limits of detection, however, there has been interest in developing one-step probing systems that would allow the process to occur faster and with less consumables. This requires a probe antibody which both recognizes the protein of interest and contains a detectable label, probes which are often available for known protein tags. The primary probe is incubated with the membrane in a manner similar to that for the primary antibody in a two-step process, and then is ready for direct detection after a series of wash steps.

Analysis

After the unbound probes are washed away, the western blot is ready for detection of the probes that are labeled and bound to the protein of interest. In practical terms, not all westerns reveal protein only at one band in a membrane. Size approximations are taken by comparing the stained bands to that of the marker or ladder loaded during electrophoresis. The process is repeated for a structural protein, such as actin or tubulin, that should not change between samples. The amount of target protein is indexed to the structural protein to control between groups. This practice ensures correction for the amount of total protein on the membrane in case of errors or incomplete transfers.

Colorimetric detection

The colorimetric detection method depends on incubation of the western blot with a substrate that reacts with the reporter enzyme (such as peroxidase) that is bound to the secondary antibody. This converts the soluble dye into an insoluble form of a different color that precipitates next to the enzyme and thereby stains the membrane. Development of the blot is then stopped by washing away the soluble dye. Protein levels are evaluated through densitometry (how intense the stain is) or spectrophotometry.

Chemiluminescent detection

Chemiluminescent detection methods depend on incubation of the western blot with a substrate that will luminesce when exposed to the reporter on the secondary antibody. The light is then detected by photographic film, and more recently by CCD cameras which captures a digital image of the western blot. The image is analysed by densitometry, which evaluates the relative amount of protein staining and quantifies the results in terms of optical density. Newer software allows further data analysis such as molecular weight analysis if appropriate standards are used.

Radioactive detection

Radioactive labels do not require enzyme substrates, but rather allow the placement of medical X-ray film directly against the western blot which develops as it is exposed to the label and creates dark regions which correspond to the protein bands of interest (see image to the right). The importance of radioactive detections methods is declining, because it is very expensive, health and safety risks are high and ECL provides a useful alternative.

Fluorescent detection

The fluorescently labeled probe is excited by light and the emission of the excitation is then detected by a photosensor such as CCD camera equipped with appropriate emission filters which captures a digital image of the western blot and allows further data analysis such as molecular weight analysis and a quantitative western blot analysis. Fluorescence is considered to be among the most sensitive detection methods for blotting analysis.

Secondary probing

One major difference between nitrocellulose and PVDF membranes relates to the ability of each to support "stripping" antibodies off and reusing the membrane for subsequent antibody probes. While there are well-established protocols available for stripping nitrocellulose membranes, the sturdier PVDF allows for easier stripping, and for more reuse before background noise limits experiments. Another difference is that, unlike nitrocellulose, PVDF must be soaked in 95% ethanol, isopropanol or methanol before use. PVDF membranes also tend to be thicker and more resistant to damage during use.

2-D Gel Electrophoresis

2-dimensional SDS-PAGE uses the principles and techniques outlined above. 2-D SDS-PAGE, as the name suggests, involves the migration of polypeptides in 2 dimensions. For example, in the first dimension polypeptides are separated according to isoelectric point, while in the second dimension polypeptides are separated according to their molecular weight. The isoelectric point of a given protein is determined by the relative number of positively (e.g. lysine and arginine) and negatively (e.g. glutamate and aspartate) charged amino acids, with negatively charged amino acids contributing to a high isoelectric point and positively charged amino acids contributing to a low isoelectric point. Samples could also be separated first under nonreducing conditions using SDS-PAGE and under reducing conditions in the second dimension, which breaks apart disulfide bonds that hold subunits together. SDS-PAGE might also be coupled with urea-PAGE for a 2-dimensional gel.

In principle, this method allows for the separation of all cellular proteins on a single large gel. A major advantage of this method is that it often distinguishes between different isoforms of a particular protein - e.g. a protein that has been phosphorylated (by addition of a negatively charged group). Proteins that have been separated can be cut out of the gel and then analysed by mass spectrometry, which identifies the protein.

Eastern blotting

It is a technique to detect protein post translational modification and is an extension of the biochemical technique of western blotting. Proteins blotted from two dimensional SDS-PAGE gel on to a PVDF or nitrocellulose membrane are analyzed for post-translational protein modifications using probes specifically designed to detect lipids, carbohydrate, phospho-moieties or any other protein modification.

The technique was developed to detect protein modifications in two species of *Ehrlichia*- *E. muris* and IOE. Cholera toxin B subunit (which detects lipids), Concanavalin A (which detects glucose moieties) and nitrophospho molybdate-methyl green (detects phosphoproteins) were used to detect protein modifications. The technique showed that the antigenic proteins of the non-virulent *E.muris* are more post-translationally modified than the highly virulent IOE.

The technique was conceptualized by S. Thomas while working on sandal spike phytoplasma and developed at the Dept. of Pathology, University of Texas Medical Branch, Galveston, Texas, while working on the intracellular bacteria, *Ehrlichia*.

Significance

Most of the proteins that are translated from mRNA undergo modifications before becoming functional in cells. The modifications collectively, are known as post-translational modifications (PTMs). The nascent or folded proteins, which are stable under physiological conditions, are then subjected to a battery of specific enzyme-catalyzed modifications on the side chains or backbones.

Post-translational protein modifications includes: acetylation, acylation (myristoylation, palmitoylation), alkylation, arginylation, biotinylation, formylation, glutamylation, glycosylation, glycylation, hydroxylation, isoprenylation, lipoylation, methylation, nitroalkylation, phosphopantetheinylation, phosphorylation, prenylation, selenation, S-nitrosylation, sulfation, transglutamination and ubiquitination (sumoylation).

Post-translational modifications occurring at the N-terminus of the amino acid chain play an important role in translocation across biological membranes. These include secretory proteins in prokaryotes and eukaryotes and also proteins that are intended to be incorporated in various

cellular and organelle membranes such as lysosomes, chloroplast, mitochondria and plasma membranes. Expression of post translated proteins is important in several diseases.

Applications of Blotting and Hybridization Techniques

1. Southern blotting technique is widely used to find specific nucleic acid sequence present in different plant species.
2. Northern blotting technique is widely used to find gene expression and regulation of specific genes.
3. By using blotting technique we can identify infectious agents present in the sample.
4. We can identify inherited disease.
5. It can be applied to mapping restriction sites in single copy gene.

Disadvantages of Blotting and Hybridization Techniques

1. The process is a complex, cumbersome and time consuming one.
2. It requires electrophoretic separation.
3. Only one gene or RNA can be analysed at a time.
4. Gives information about presence of DNA, RNA or proteins but does not give information about regulation and gene interaction.

Dot Blotting Techniques - The drawbacks of blotting techniques have lead to the development of dot blotting technique which is more advanced, less time consuming, accurate and applicable to a wide variety of gene/source simultaneously.

The dot or slot blotting technique is the most widely used of all techniques for analysing. None of the blot methods require electrophoresis prior to blotting and hybridization. Hybridization of cloned DNA without electrophoretic separation is called as dot blotting.

Plaque or Colony Blotting Techniques - This method was first developed by Granstiens and Hogness (1975). This method is used to identify which colony of bacteria contains the DNA of interest among thousands. In this procedure, the bacterial colonies to be screened are transferred onto nitrocellulose or nylon membrane by using replica plating.

Due to the negative charge of the cell surface, some cells bind to the nitrocellulose membrane. Then the membrane is placed in a solution of 0.5 N NaOH to break the cell surface, convert

dsDNA to ssDNA and to bind DNA to the membrane. Later, the membrane is transferred to a solution containing protease solution after neutralizing with neutralization solution.

The DNA is fixed tightly to membrane by either W cross linking or oven baking. This membrane is used for hybridization with a probe and analysed by using autoradiography or biotin method for positive hybridization. A colony whose DNA print (as replica plating provides a replica print master plate colony on the membrane) gives a positive hybridization can be picked from the master plate.

Plaque blotting is similar to colony blotting; the only difference is that instead of bacterial colony, a plaque is transferred onto the membrane. Benton and Davis developed this method in 1977. The greatest advantage of this method is that several identical DNA prints can be easily made from a single master plate containing bacteria/plaques which are to be made.

Dot Plot Assay Techniques - This method is widely used to hybridize DNA from a single cell type against a wide variety of probes, for example, for a viral infection which cannot be identified by normal conventional methods or if we want to know what all genes are expressed in a single cell type (e.g. brain cell).

Cell type or cells that are to be screened are placed on the membrane as 'dot' in the order of rows and columns. Then the cells are denatured by using enzymes or detergents (SDS) and DNA is fixed by using W - cross link or oven baking. This membrane is then used for hybridization by using probes (which are specific to a gene).

Questions

1. The technique in which nucleic acids or proteins are immobilized onto a solid support is called as

- a). **Blotting**
- b). Hybridisation
- c). Immobilization
- d). None of the above

2. Blotting techniques are used to identify.....

- a). Unique proteins
- b). Nucleic acid sequences
- c). **Both a and b**
- d). None of the above

3. Blotting techniques consist of..... separate steps.

- a). **4**
- b). 3
- c). 5
- d). None of the above

4. Blotting techniques consist of..... separate steps.

- a). **4**
- b). 3
- c). 5
- d). None of the above

5. Southern blot is a method used to check for the presence of.....

- a). **DNA**
- b). RNA
- c). Protein
- d). None of the above

6. Southern blot was invented by

- a). **Edwin Southern**
- b). James Alwine
- c). David Kemp
- d). None of the above

7. Northern blot was invented by

- a). George Stark
- b). James Alwine
- c). David Kemp
- d). **All the above**

8. Northern blot is a method used to check for the presence of.....

- a). DNA
- b). **RNA**
- c). Protein
- d). None of the above

8. Northern blot is used.....
- a). Overexpression of oncogenes b). Downregulation of tumor-suppressor genes
c). Both a and b d). None of the above
9. The advantages of Northern blot are
- a). Detection of RNA size b). Quality and quantity of RNA can be measured
c). Use of probes with partial homology **d). All the above**
10. Immunoblot is the other name of
- a). Northern blot b). Southern blot
c). Western blot d). None of the above
11. Western blot is a method used to check for the presence of.....
- a). DNA b). RNA
c). Protein d). None of the above
12. Southern blot was invented by
- a). Edwin Southern b). James Alwine
c). David Kemp **d). Neal Burnette**
13. Eastern blot is the extension of
- a). Northern blot b). Southern blot
c). Western blot d). None of the above
14. Eastern blot is a method used to check for the presence of.....
- a). DNA b). RNA
c). Protein **d). Protein post translational modification**
15. Eastern blot was invented by
- a). Edwin Southern b). James Alwine
c). Thomas d). Neal Burnette

16. The disadvantages of blotting techniques include

- a). Complex, cumbersome and time consuming process
- b). No information about regulation and gene interaction
- c). Analysis of one gene or RNA at a time
- d). All the above**

DNA finger printing

DNA (Deoxyribonucleic acid) is a chemical structure that forms chromosomes. A piece of a chromosome that dictates a particular trait is called a gene.

Structurally, DNA is a double helix: two strands of genetic material spiraled around each other. Each strand contains a sequence of bases (also called nucleotides). A base is one of four chemicals (adenine, guanine, cytosine and thymine).

The two strands of DNA are connected at each base. Each base will only bond with one other base, as follows: Adenine (A) will only bond with thymine (T), and guanine (G) will only bond with cytosine (C). Suppose one strand of DNA looks like this:

A-A-C-T-G-A-T-A-G-G-T-C-T-A-G

The DNA strand bound to it will look like this:

T-T-G-A-C-T-A-T-C-C-A-G-A-T-C

Together, the section of DNA would be represented like this:

T-T-G-A-C-T-A-T-C-C-A-G-A-T-C

A-A-C-T-G-A-T-A-G-G-T-C-T-A-G

DNA strands are read in a particular direction, from the top (called the 5' or "five prime" end) to the bottom (called the 3' or "three prime" end). In a double helix, the strands go opposite ways:

5' T-T-G-A-C-T-A-T-C-C-A-G-A-T-C 3'

3' A-A-C-T-G-A-T-A-G-G-T-C-T-A-G 5'

The chemical structure of DNA is as follows:

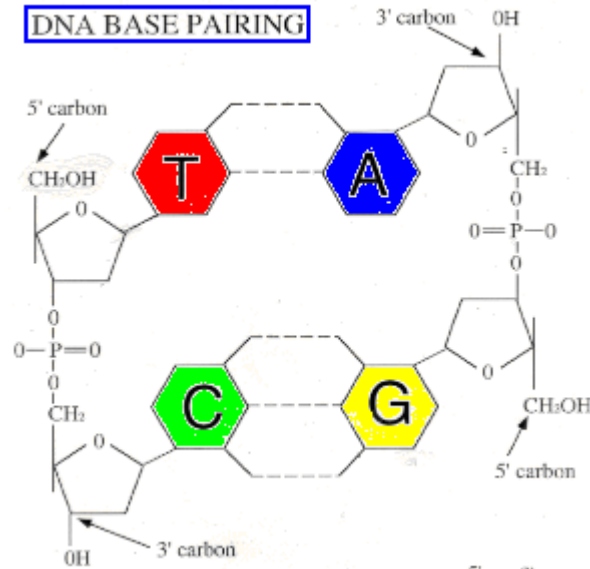

What is DNA fingerprinting?

The chemical structure of everyone's DNA is the same. The only difference between people (or any animal) is the order of the base pairs. There are so many millions of base pairs in each person's DNA that every person has a different sequence.

Using these sequences, every person could be identified solely by the sequence of their base pairs. However, because there are so many millions of base pairs, the task would be very time-consuming. Instead, scientists are able to use a shorter method, because of repeating patterns in DNA.

These patterns do not, however, give an individual "fingerprint," but they are able to determine whether two DNA samples are from the same person, related people, or non-related people. Scientists use a small number of sequences of DNA that are known to vary among individuals a great deal, and analyze those to get a certain probability of a match.

How is DNA fingerprinting done

Southern Blot

The Southern Blot is one way to analyze the genetic patterns which appear in a person's DNA. Performing a Southern Blot involves:

1. Isolating the DNA in question from the rest of the cellular material in the nucleus. This can be done either chemically, by using a detergent to wash the extra material from the DNA, or mechanically, by applying a large amount of pressure in order to "squeeze out" the DNA.
2. Cutting the DNA into several pieces of different sizes. This is done using one or more restriction enzymes.
3. Sorting the DNA pieces by size. The process by which the size separation, "size fractionation," is done is called gel electrophoresis. The DNA is poured into a gel, such as agarose, and an electrical charge is applied to the gel, with the positive charge at the bottom and the negative charge at the top. Because DNA has a slightly negative charge, the pieces of DNA will be attracted towards the bottom of the gel; the smaller pieces, however, will be able to move more quickly and thus further towards the bottom than the larger pieces. The different-sized pieces of DNA will therefore be separated by size, with the smaller pieces towards the bottom and the larger pieces towards the top.
4. Denaturing the DNA, so that all of the DNA is rendered single-stranded. This can be done either by heating or chemically treating the DNA in the gel.
5. Blotting the DNA. The gel with the size-fractionated DNA is applied to a sheet of nitrocellulose paper, and then baked to permanently attach the DNA to the sheet. The Southern Blot is now ready to be analyzed.

In order to analyze a Southern Blot, a radioactive genetic probe is used in a hybridization reaction with the DNA in question (*see next topics for more information*). If an X-ray is taken of the Southern Blot after a radioactive probe has been allowed to bond with the denatured DNA on the paper, only the areas where the radioactive probe binds [red] will show up on the film. This allows researchers to identify, in a particular person's DNA, the occurrence and frequency of the particular genetic pattern contained in the probe.

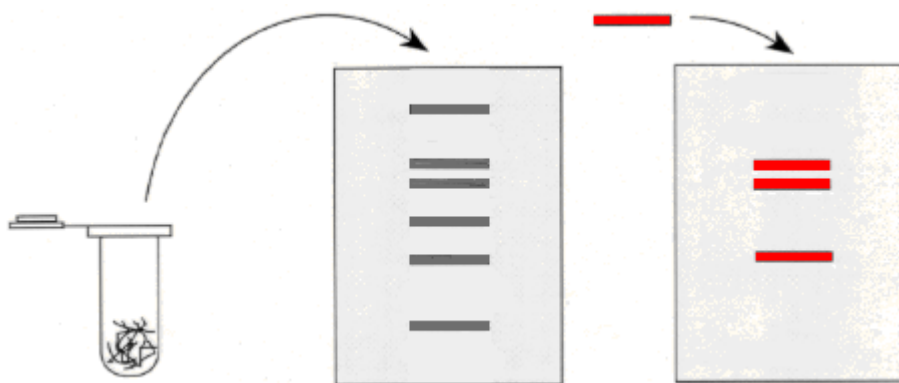

Making a radioactive probe

1. Obtain some DNA polymerase [pink]. Put the DNA to be made radioactive (radiolabeled) into a tube.



2. Introduce nicks, or horizontal breaks along a strand, into the DNA you want to radiolabel. At the same time, add individual nucleotides to the nicked DNA, one of which, ³²P [light blue], is radioactive.



3. Add the DNA polymerase [pink] to the tube with the nicked DNA and the individual nucleotides. The DNA polymerase will become immediately attracted to the nicks in the DNA and attempt to repair the DNA, starting from the 5' end and moving toward the 3' end.



4. The DNA polymerase [pink] begins repairing the nicked DNA. It destroys all the existing bonds in front of it and places the new nucleotides, gathered from the individual nucleotides mixed in the tube, behind it. Whenever a G base is read in the lower strand, a radioactive ³²P [light blue] base is placed in the new strand. In this fashion, the nicked strand, as it is repaired by the DNA polymerase, is made radioactive by the inclusion of radioactive ³²P bases.

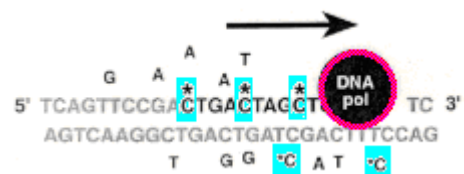

5. The nicked DNA is then heated, splitting the two strands of DNA apart. This creates single-stranded radioactive and non-radioactive pieces. The radioactive DNA, now called a probe [light blue], is ready for use.

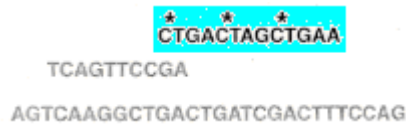

Creating a hybridization reaction

1. Hybridization is the coming together, or binding, of two genetic sequences. The binding occurs because of the hydrogen bonds [pink] between base pairs. Between a A base and a T base, there are two hydrogen bonds; between a C base and a G base, there are three hydrogen bonds.



2. When making use of hybridization in the laboratory, DNA must first be denatured, usually by using heat or chemicals. Denaturing is a process by which the hydrogen bonds of the original double-stranded DNA are broken, leaving a single strand of DNA whose bases are available for hydrogen bonding.

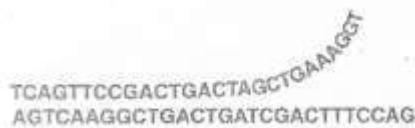

3. Once the DNA has been denatured, a single-stranded radioactive probe [light blue] can be used to see if the denatured DNA contains a sequence similar to that on the probe. The denatured DNA is put into a plastic bag along with the probe and some saline liquid; the bag is then shaken to allow sloshing. If the probe finds a fit, it will bind to the DNA.



4. The fit of the probe to the DNA does not have to be exact. Sequences of varying homology can stick to the DNA even if the fit is poor; the poorer the fit, the fewer the hydrogen bonds between the probe [light blue] and the denatured DNA. The ability of low-homology probes to still bind to DNA can be manipulated through varying the temperature of the hybridization reaction environment, or by varying the amount of salt in the sloshing mixture.



VNTRs

Every strand of DNA has pieces that contain genetic information which informs an organism's development (exons) and pieces that, apparently, supply no relevant genetic information at all (introns). Although the introns may seem useless, it has been found that they contain repeated sequences of base pairs. These sequences, called Variable Number Tandem Repeats (VNTRs), can contain anywhere from twenty to one hundred base pairs.

Every human being has some VNTRs. To determine if a person has a particular VNTR, a Southern Blot is performed, and then the Southern Blot is probed, through a hybridization reaction, with a radioactive version of the VNTR in question. The pattern which results from this process is what is often referred to as a DNA fingerprint.

A given person's VNTRs come from the genetic information donated by his or her parents; he or she could have VNTRs inherited from his or her mother or father, or a combination, but never a VNTR either of his or her parents do not have. Shown below are the VNTR patterns for Mrs. Nguyen [blue], Mr. Nguyen [yellow], and their four children: D1 (the Nguyens' biological daughter), D2 (Mr. Nguyen's step-daughter, child of Mrs. Nguyen and her former husband [red]), S1 (the Nguyens' biological son), and S2

(the Nguyens' adopted son, not biologically related [his parents are light and dark green]).

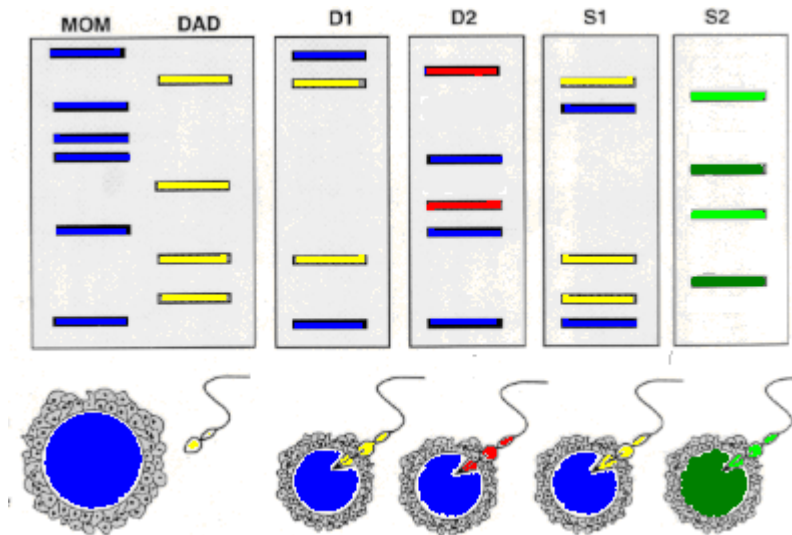

Because VNTR patterns are inherited genetically, a given person's VNTR pattern is more or less unique. The more VNTR probes used to analyze a person's VNTR pattern, the more distinctive and individualized that pattern, or DNA fingerprint, will be.

Problems with DNA fingerprinting

Like nearly everything else in the scientific world, nothing about DNA fingerprinting is 100% assured. The term DNA fingerprint is, in one sense, a misnomer: it implies that, like a fingerprint, the VNTR pattern for a given person is utterly and completely unique to that person. Actually, all that a VNTR pattern can do is present a probability that the person in question is indeed the person to whom the VNTR pattern (of the child, the criminal evidence, or whatever else) belongs. Given, that probability might be 1 in 20 billion, which would indicate that the person can be reasonably matched with the DNA fingerprint; then again, that probability might only be 1 in 20, leaving a large amount of doubt regarding the specific identity of the VNTR pattern's owner.

1. Generating a high probability

The probability of a DNA fingerprint belonging to a specific person needs to be reasonably high--especially in criminal cases, where the association helps establish a suspect's guilt or innocence. Using certain rare VNTRs or combinations of VNTRs to create the VNTR pattern increases the probability that the two DNA samples do indeed

match (as opposed to look alike, but not actually come from the same person) or correlate (in the case of parents and children).

2. Problems with determining probability

A. Population genetics

VNTRs, because they are results of genetic inheritance, are not distributed evenly across all of human population. A given VNTR cannot, therefore, have a stable probability of occurrence; it will vary depending on an individual's genetic background. The difference in probabilities is particularly visible across racial lines. Some VNTRs that occur very frequently among Hispanics will occur very rarely among Caucasians or African-Americans. Currently, not enough is known about the VNTR frequency distributions among ethnic groups to determine accurate probabilities for individuals within those groups; the heterogeneous genetic composition of interracial individuals, who are growing in number, presents an entirely new set of questions. Further experimentation in this area, known as population genetics, has been surrounded with and hindered by controversy, because the idea of identifying people through genetic anomalies along racial lines comes alarmingly close to the eugenics and ethnic purification movements of the recent past, and, some argue, could provide a scientific basis for racial discrimination.

B. Technical difficulties

Errors in the hybridization and probing process must also be figured into the probability, and often the idea of error is simply not acceptable. Most people will agree that an innocent person should not be sent to jail, a guilty person allowed to walk free, or a biological mother denied her legal right to custody of her children, simply because a lab technician did not conduct an experiment accurately. When the DNA sample available is minuscule, this is an important consideration, because there is not much room for error, especially if the analysis of the DNA sample involves amplification of the sample (creating a much larger sample of genetically identical DNA from what little material is available), because if the wrong DNA is amplified (i.e. a skin cell from the lab technician) the consequences can be profoundly detrimental. Until recently, the standards for determining DNA fingerprinting matches, and for laboratory security and accuracy which would minimize error, were neither stringent nor universally codified, causing a great deal of public outcry.

DNA markers in plant genome analysis

With the advent of molecular markers, a new generation of markers has been introduced over the last two decades, which has revolutionized the entire scenario of biological sciences. DNA-based molecular markers have acted as versatile tools and have found their own position in various fields like taxonomy, physiology, embryology, genetic engineering, etc. They are no longer looked upon as simple DNA fingerprinting markers in variability studies or as mere forensic tools. Ever since their development, they are constantly being modified to enhance their utility and to bring about automation in the process of genome analysis. The discovery of PCR (polymerase chain reaction) was a landmark in this effort and proved to be a unique process that brought about a new class of DNA profiling markers. This facilitated the development of marker-based gene tags, map-based cloning of agronomically important genes, variability studies, phylogenetic analysis, synteny mapping, marker-assisted selection of desirable genotypes, etc. Thus giving new dimensions to concerted efforts of breeding and marker-aided selection that can reduce the time span of developing new and better varieties and will make the dream of super varieties come true. These DNA markers offer several advantages over traditional phenotypic markers, as they provide data that can be analysed objectively.

Plants have always been looked upon as a key source of energy for survival and evolution of the animal kingdom, thus forming a base for every ecological pyramid. Over the last few decades plant genomics has been studied extensively bringing about a revolution in this area. Molecular markers, useful for plant genome analysis, have now become an important tool in this revolution. In this article we attempt to review most of the available DNA markers that can be routinely employed in various aspects of plant genome analysis such as taxonomy, phylogeny, ecology, genetics and plant breeding.

During the early period of research, classical strategies including comparative anatomy, physiology and embryology were employed in genetic analysis to determine inter- and intra-species variability. In the past decade, however, molecular markers have very rapidly complemented the classical strategies. Molecular markers include biochemical constituents (e.g. secondary metabolites in plants) and macromolecules, viz. proteins and deoxyribonucleic acids (DNA). Analysis of secondary metabolites is, however, restricted to those plants that produce a suitable range of metabolites which can be easily analysed and which can distinguish between varieties. These metabolites which are being used as

markers should be ideally neutral to environmental effects or management practices. Hence, amongst the molecular markers used, DNA markers are more suitable and ubiquitous to most of the living organisms.

DNA-based molecular markers

Genetic polymorphism is classically defined as the simultaneous occurrence of a trait in the same population of two or more discontinuous variants or genotypes. Although DNA sequencing is a straightforward approach for identifying variations at a locus, it is expensive and laborious. A wide variety of techniques have, therefore, been developed in the past few years for visualizing DNA sequence polymorphism.

The term DNA-fingerprinting was introduced for the first time by Alec Jeffrey in 1985 to describe bar-code-like DNA fragment patterns generated by multilocus probes after electrophoretic separation of genomic DNA fragments. The emerging patterns make up a unique feature of the analysed individual and are currently considered to be the ultimate tool for biological individualization. Recently, the term DNA fingerprinting/profiling is used to describe the combined use of several single locus detection systems and is being used as versatile tools for investigating various aspects of plant genomes. These include characterization of genetic variability, genome fingerprinting, genome mapping, gene localization, analysis of genome evolution, population genetics, taxonomy, plant breeding, and diagnostics.

Properties desirable for ideal DNA markers

- Highly polymorphic nature
- Codominant inheritance (determination of homozygous and heterozygous states of diploid organisms)
- Frequent occurrence in genome
- Selective neutral behaviour (the DNA sequences of any organism are neutral to environmental conditions or management practices)
- Easy access (availability)
- Easy and fast assay
- High reproducibility
- Easy exchange of data between laboratories.

It is extremely difficult to find a molecular marker which would meet all the above criteria. Depending on the type of study to be undertaken, a marker system can be identified that would fulfill atleast a few of the above characteristics.

Types of molecular markers

Various types of molecular markers are utilized to evaluate DNA polymorphism and are generally classified as hybridization-based markers and polymerase chain reaction (PCR)-based markers. In the former, DNA profiles are visualized by hybridizing the restriction enzyme-digested DNA, to a labelled probe, which is a DNA fragment of known origin or sequence. PCR-based markers involve *in vitro* amplification of particular DNA sequences or loci, with the help of specifically or arbitrarily chosen oligonucleotide sequences (primers) and a thermostable DNA polymerase enzyme. The amplified fragments are separated electrophoretically and banding patterns are detected by different methods such as staining and autoradiography. PCR is a versatile technique invented during the mid-1980s. Ever since thermostable DNA polymerase was introduced in 1988, the use of PCR in research and clinical laboratories has increased tremendously. The primer sequences are chosen to allow base-specific binding to the template in reverse orientation. PCR is extremely sensitive and operates at a very high speed. Its application for diverse purposes has opened up a multitude of new possibilities in the field of molecular biology.

For simplicity, we have divided the review in two parts. The first part is a general description of most of the available DNA marker types, while the second includes their application in plant genomics and breeding programmes.

Types and description of DNA markers

Single or low copy probes

Restriction fragment length polymorphism (RFLP). RFLPs are simply inherited naturally occurring Mendelian characters. They have their origin in the DNA rearrangements that occur due to evolutionary processes, point mutations within the restriction enzyme recognition site sequences, insertions or deletions within the fragments, and unequal crossing over.

In RFLP analysis, restriction enzyme-digested genomic DNA is resolved by gel electrophoresis and then blotted on to a nitrocellulose membrane. Specific banding patterns are then visualized by hybridization with labelled probe. These probes are mostly species-

specific single locus probes of about 0.5–3.0 kb in size, obtained from a cDNA library or a genomic library. The genomic libraries are easy to construct and almost all sequence types are included; however, a large number of interspersed repeats are found in inserts, that detect a large number of restriction fragments forming complex patterns. In plants, this problem is overcome to some extent by using methylation-sensitive restriction enzyme *Pst*I. This helps to obtain low copy DNA sequences of small fragment sizes, which are preferred in RFLP analysis. On the other hand cDNA libraries are difficult to construct, however, they are more popular as actual genes are analysed and they contain fewer repeat sequences. The selection of appropriate source for RFLP probe varies, with the requirement of particular application under consideration. Though genomic library probes may exhibit greater variability than gene probes from cDNA libraries, a few studies reveal the converse. This observation may be because cDNA probes not only detect variation in coding regions of the corresponding genes but also regions flanking genes and introns of the gene.

RFLP markers were used for the first time in the construction of genetic maps by Botstein *et al.* RFLPs, being codominant markers, can detect coupling phase of DNA molecules, as DNA fragments from all homologous chromosomes are detected. They are very reliable markers in linkage analysis and breeding and can easily determine if a linked trait is present in a homozygous or heterozygous state in an individual, an information highly desirable for recessive traits¹². However, their utility has been hampered due to the large amount of DNA required for restriction digestion and Southern blotting. The requirement of radioactive isotope makes the analysis relatively expensive and hazardous. The assay is time-consuming and labour-intensive and only one out of several markers may be polymorphic, which is highly inconvenient especially for crosses between closely-related species. Their inability to detect single base changes restricts their use in detecting point mutations occurring within the regions at which they are detecting polymorphism.

Restriction landmark genomic scanning (RLGS)

This method, introduced for the first time by Hatada *et al.*, for genomic DNA analysis of higher organisms, is based on the principle that restriction enzyme sites can be used as landmarks. It employs direct labelling of genomic DNA at the restriction site and two-dimensional (2D) electrophoresis to resolve and identify these landmarks. The technique has proven its utility in genome analysis of closely-related cultivars and for obtaining polymorphic markers that can be cloned by spot target method. It has been used as a new fingerprinting technique for rice cultivars.

RFLP markers converted in to PCR based-markers

Sequence-tagged sites (STS)

RFLP probes specifically linked to a desired trait can be converted into PCR-based STS markers based on nucleotide sequence of the probe giving polymorphic band pattern, to obtain specific amplicon. Using this technique, tedious hybridization procedures involved in RFLP analysis can be overcome. This approach is extremely useful for studying the relationship between various species. When these markers are linked to some specific traits, for example powdery mildew resistance gene or stem rust resistance gene in barley, they can be easily integrated into plant breeding programmes for marker-assisted selection of the trait of interest.

Allele-specific associated primers (ASAPs)

To obtain an allele-specific marker, specific allele (either in homozygous or heterozygous state) is sequenced and specific primers are designed for amplification of DNA template to generate a single fragment at stringent annealing temperatures. These markers tag specific alleles in the genome and are more or less similar to SCARs.

Expressed sequence tag markers (EST)

This term was introduced by Adams *et al.* Such markers are obtained by partial sequencing of random cDNA clones. Once generated, they are useful in cloning specific genes of interest and synteny mapping of functional genes in various related organisms. ESTs are popularly used in full genome sequencing and mapping programmes underway for a number of organisms and for identifying active genes thus helping in identification of diagnostic markers. Moreover, an EST that appears to be unique helps to isolate new genes. EST markers are identified to a large extent for rice, *Arabidopsis*, etc. wherein thousands of functional cDNA clones are being converted in to EST markers.

Single strand conformation polymorphism (SSCP)

This is a powerful and rapid technique for gene analysis particularly for detection of point mutations and typing of DNA polymorphism. SSCP can identify heterozygosity of DNA fragments of the same molecular weight and can even detect changes of a few nucleotide bases as the mobility of the single-stranded DNA changes with change in its GC content due to its conformational change. To overcome problems of reannealing and complex banding patterns, an improved technique called asymmetric-PCR SSCP was developed, wherein the denaturation step was eliminated and a large-sized sample could be loaded for

gel electrophoresis, making it a potential tool for high throughput DNA polymorphism. It was found useful in the detection of heritable human diseases. In plants, however, it is not well developed although its application in discriminating progenies can be exploited, once suitable primers are designed for agronomically important traits.

Multi locus probes

Repetitive DNA

A major step forward in genetic identification is the discovery that about 30–90% of the genome of virtually all the species is constituted by regions of repetitive DNA, which are highly polymorphic in nature. These regions contain genetic loci comprising several hundred alleles, differing from each other with respect to length, sequence or both and they are interspersed in tandem arrays ubiquitously. The repetitive DNA regions play an important role in absorbing mutations in the genome. Of the mutations that occur in the genome, only inherited mutations play a vital role in evolution or polymorphism. Thus repetitive DNA and mutational forces functional in nature together form the basis of a number of marker systems that are useful for various applications in plant genome analysis. The markers belonging to this class are both hybridization-based and PCR-based.

Microsatellites and minisatellites

The term microsatellite was coined by Litt and Luty, while the term minisatellite was introduced by Jeffrey. Both are multilocus probes creating complex banding patterns and are usually non-species specific occurring ubiquitously. They essentially belong to the repetitive DNA family. Fingerprints generated by these probes are also known as oligonucleotide fingerprints. The methodology has been derived from RFLP and specific fragments are visualized by hybridization with a labelled micro- or minisatellite probe.

Minisatellites are tandem repeats with a monomer repeat length of about 11–60 bp, while microsatellites or short tandem repeats/simple sequence repeats (STRs/SSRs) consist of 1 to 6 bp long monomer sequence that is repeated several times. These loci contain tandem repeats that vary in the number of repeat units between genotypes and are referred to as variable number of tandem repeats (VNTRs) (i.e. a single locus that contains variable number of tandem repeats between individuals) or hypervariable regions (HVRs) (i.e. numerous loci containing tandem repeats within a genome generating high levels of polymorphism between individuals). Microsatellites and minisatellites thus form an ideal marker system creating complex banding patterns by simultaneously detecting

multiple DNA loci. Some of the prominent features of these markers are that they are dominant fingerprinting markers and codominant STMS (sequence tagged microsatellites) markers. Many alleles exist in a population, the level of heterozygosity is high and they follow Mendelian inheritance.

Minisatellite and microsatellite sequences converted into PCR-based markers

Sequence-tagged microsatellite site markers (STMS)

This method includes DNA polymorphism using specific primers designed from the sequence data of a specific locus. Primers complementary to the flanking regions of the simple sequence repeat loci yield highly polymorphic amplification products. Polymorphisms appear because of variation in the number of tandem repeats (VNTR loci) in a given repeat motif. Tri- and tetranucleotide microsatellites are more popular for STMS analysis because they present a clear banding pattern after PCR and gel electrophoresis. However, dinucleotides are generally abundant in genomes and have been used as markers e.g. (CA) n (AG) n and (AT) n . The di- and tetranucleotide repeats are present mostly in the non-coding regions of the genome, while 57% of trinucleotide repeats are shown to reside in or around the genes. A very good relationship between the number of alleles detected and the total number of simple repeats within the targeted microsatellite DNA has been observed. Thus larger the repeat number in the microsatellite DNA, greater is the number of alleles detected in a large population.

Direct amplification of minisatellite DNA markers (DAMD-PCR)

This technique, introduced by Heath *et al.*, has been explored as a means of generating DNA probes useful for detecting polymorphism. DAMD-PCR clones can yield individual-specific DNA fingerprinting pattern and thus have the potential as markers for species differentiation and cultivar identification.

Inter simple sequence repeat markers (ISSR)

In this technique, reported by Zietkiewicz *et al.*, primers based on microsatellites are utilized to amplify inter-SSR DNA sequences. Here, various microsatellites anchored at the 3' end are used for amplifying genomic DNA which increases their specificity. These are mostly dominant markers, though occasionally a few of them exhibit codominance. An unlimited number of primers can be synthesized for various combinations of di-, tri-, tetra- and pentanucleotides [(4) 3 = 64, (4) 4 = 256] etc. with an anchor made up of a few bases and can be exploited for a broad range of applications in plant species.

Other repetitive DNA-type markers

Transposable elements

A large number of transposable repeat elements have been studied in plants; however, only a few have been exploited as molecular markers. In evolutionary terms, they have contributed to genetic differences between species and individuals by playing a role in retrotransposition events promoting unequal crossing over. Retrotransposon-mediated fingerprinting has been shown to be an efficient fingerprinting method for detection of genetic differences between different species.

Alu-repeats

This strategy was developed to fingerprint genotypes using semi specific primers, complementary to repetitive DNA elements called 'Alu-repeats', in human genome analysis. *Alu* repeats are a class of randomly repeated interspersed DNA, preferentially used for *Alu* PCR as they reveal considerable levels of polymorphism. These representatives of short and long interspersed nuclear elements are known as *SINES*. *Alu* elements are approximately 300 bp in size and have been suggested to be originated from special RNA species that have been reintegrated at a rate of approximately one integration event per 10000 years. These repeats have been studied largely in humans, while their function in plants remains largely unexplored.

Repeat complementary primers

As an alternative to the interspersed repeats, primers complementary to other repetitive sequence elements were also successfully used for generation of polymorphisms, e.g. introns/exons splice junctions, tRNA genes, 5sRNA genes and Zn-finger protein genes. Primers complementary to specific exons, resulting in the amplification of the intervening introns have been studied by Lessa *et al.* One of the strengths of these new strategies is that they are more amenable to automation than the conventional hybridization-based techniques.

Arbitrary sequence markers

Randomly-amplified polymorphic DNA markers (RAPD)

In 1991 Welsh and McClelland developed a new PCR-based genetic assay namely randomly amplified polymorphic DNA (RAPD). This procedure detects nucleotide sequence polymorphisms in DNA by using a single primer of arbitrary nucleotide sequence. In this reaction, a single species of primer anneals to the genomic DNA at two different sites on

complementary strands of DNA template. If these priming sites are within an amplifiable range of each other, a discrete DNA product is formed through thermocyclic amplification. On an average, each primer directs amplification of several discrete loci in the genome, making the assay useful for efficient screening of nucleotide sequence polymorphism between individuals. However, due to the stochastic nature of DNA amplification with random sequence primers, it is important to optimize and maintain consistent reaction conditions for reproducible DNA amplification. They are dominant markers and hence have limitations in their use as markers for mapping, which can be overcome to some extent by selecting those markers that are linked in coupling⁴³. RAPD assay has been used by several groups as efficient tools for identification of markers linked to agronomically important traits, which are introgressed during the development of near isogenic lines. The application of RAPDs and their related modified markers in variability analysis and individual-specific genotyping has largely been carried out, but is less popular due to problems such as poor reproducibility faint or fuzzy products, and difficulty in scoring bands, which lead to inappropriate inferences.

Some variations in the RAPD technique include

DNA amplification fingerprinting (DAF)

Caetano-Anolles *et al.* employed single arbitrary primers as short as 5 bases to amplify DNA using polymerase chain reaction. In a spectrum of products obtained, simple patterns are useful as genetic markers for mapping, while more complex patterns are useful for DNA fingerprinting. Band patterns are reproducible and can be analysed using polyacrylamide gel electrophoresis and silver staining. DAF requires careful optimization of parameters; however, it is extremely amenable to automation and fluorescent tagging of primers for early and easy determination of amplified products. DAF profiles can be tailored by employing various modifications such as predigesting of template. This technique has been useful in genetic typing and mapping.

Arbitrary primed polymerase chain reaction (AP-PCR)

This is a special case of RAPD, wherein discrete amplification patterns are generated by employing single primers of 10–50 bases in length in PCR of genomic DNA. In the first two cycles, annealing is under non-stringent conditions. The final products are structurally similar to RAPD products. Compared to DAF, this variant of RAPD is not very popular as it involves autoradiography. Recently, however, it has been simplified by separating the fragments on agarose gels and using ethidium bromide staining for visualization.

Sequence characterized amplified regions for amplification of specific band (SCAR)

Michelmore *et al.* and Martin *et al.* introduced this technique wherein the RAPD marker termini are sequenced and longer primers are designed (22–24 nucleotide bases long) for specific amplification of a particular locus. These are similar to STS markers in construction and application. The presence or absence of the band indicates variation in sequence. These are better reproducible than RAPDs. SCARs are usually dominant markers, however, some of them can be converted into codominant markers by digesting them with tetra cutting restriction enzymes and polymorphism can be deduced by either denaturing gel electrophoresis or SSCP. Compared to arbitrary primers, SCARs exhibit several advantages in mapping studies (codominant SCARs are informative for genetic mapping than dominant RAPDs), map-based cloning as they can be used to screen pooled genomic libraries by PCR, physical mapping, locus specificity, etc. SCARs also allow comparative mapping or homology studies among related species, thus making it an extremely adaptable concept in the near future.

Cleaved amplified polymorphic sequences (CAPs)

These polymorphic patterns are generated by restriction enzyme digestion of PCR products. Such digests are compared for their differential migration during electrophoresis. PCR primer for this process can be synthesized based on the sequence information available in databank of genomic or cDNA sequences or cloned RAPD bands. These markers are codominant in nature.

Randomly amplified microsatellite polymorphisms (RAMPO)

In this PCR-based strategy, genomic DNA is first amplified using arbitrary (RAPD) primers. The amplified products are then electrophoretically separated and the dried gel is hybridized with microsatellite oligonucleotide probes. Several advantages of oligonucleotide fingerprinting, RAPD and microsatellite-primed PCR are thus combined, these being the speed of the assay, the high sensitivity, the high level of variability detected and the non-requirement of prior DNA sequence information. This technique has been successfully employed in the genetic fingerprinting of tomato, kiwi fruit and closely-related genotypes of *D. bulbifera*.

Amplified fragment length polymorphism (AFLP)

A recent approach by Zabeau *et al.*, known as AFLP, is a technique based on the detection of genomic restriction fragments by PCR amplification and can be used for DNAs of any

origin or complexity. The fingerprints are produced, without any prior knowledge of sequence, using a limited set of generic primers. The number of fragments detected in a single reaction can be 'tuned' by selection of specific primer sets. AFLP technique is reliable since stringent reaction conditions are used for primer annealing. This technique thus shows an ingenious combination of RFLP and PCR techniques and is extremely useful in detection of polymorphism between closely related genotypes.

AFLP procedure mainly involves 3 steps

(a) Restriction of DNA using a rare cutting and a commonly cutting restriction enzyme simultaneously (such as *MseI* and *EcoRI*) followed by ligation of oligonucleotide adapters, of defined sequences including the respective restriction enzyme sites.

(b) Selective amplifications of sets of restriction fragments, using specifically designed primers. To achieve this, the 5' region of the primer is made such that it would contain both the restriction enzyme sites on either sides of the fragment complementary to the respective adapters, while the 3' ends extend for a few arbitrarily chosen nucleotides into the restriction fragments.

(c) Gel analysis of the amplified fragments. AFLP analysis depicts unique fingerprints regardless of the origin and complexity of the genome. Most AFLP fragments correspond to unique positions on the genome and hence can be exploited as landmarks in genetic and physical mapping. AFLPs are extremely useful as tools for DNA fingerprinting and also for cloning and mapping of variety-specific genomic DNA sequences. Similar to RAPDs, the bands of interest obtained by AFLP can be converted into SCARs. Thus AFLP provides a newly developed, important tool for a variety of applications.

Table 3. Comparison of the five most widely used DNA markers in plants.

	RFLP	Microsatellite	RAPD	AFLP	ISSR
Genomic abundance	high	medium	very high	very high	medium
Part of genome surveyed	low copy coding regions	whole genome	whole genome	whole genome	whole genome
Amount of DNA required	high	low	low	medium	low
Type of polymorphism	single base changes, insertion, deletion	changes in length of repeats	single base changes, insertion, deletion	single base changes, insertion, deletion	single base changes, insertion, deletion
Level of polymorphism ^a	medium	high	high	very high	high
Effective multiplex ratio ^b	low	medium	medium	high	medium
Marker index ^c	low	medium	medium	high	medium
Inheritance	codominant	codominant	dominant	dominant	dominant
Detection of alleles	yes	yes	no	no	no
Ease of use	labour intensive	easy	easy	difficult initially	easy
Automation	low	high	medium	medium	medium
Reproducibility (reliability)	high	high	intermediate	high	medium to high
Type of probes/primers	low copy genomic DNA or cDNA clones	specific repeat DNA sequence	usually 10 bp random nucleotides	specific sequence	specific repeat DNA sequence
Cloning and/or sequencing	yes	yes	no	no	no
Radioactive detection	usually yes	no	no	yes/no	no
Development/start-up costs	high	high	low	medium	medium
Utility for genetic mapping	species specific	species specific	cross specific	cross specific	cross specific
Proprietary rights status	No	No (some are licensed)	licensed	licensed	no

^a Level of polymorphism (average heterozygosity) is an average of the probability that two alleles taken at random can be distinguished

^b Effective multiplex ratio is the number of polymorphic loci analysed per experiment in the germplasm tested.

^c Marker index is the product of the average expected heterozygosity and the effective multiplex ratio.

Table 1. Advantages and disadvantages of most commonly-used DNA markers for QTL analysis

Molecular marker	Codominant (C) or Dominant (D)	Advantages	Disadvantages	References
Restriction fragment length polymorphism (RFLP)	C	<ul style="list-style-type: none"> ● Robust ● Reliable ● Transferable across populations 	<ul style="list-style-type: none"> ● Time-consuming, laborious and expensive ● Large amounts of DNA required ● Limited polymorphism (especially in related lines) 	Beckmann & Soller (1986), Kochert (1994), Tanksley et al. (1989)
Random amplified polymorphic DNA (RAPD)	D	<ul style="list-style-type: none"> ● Quick and simple ● Inexpensive ● Multiple loci from a single primer possible ● Small amounts of DNA required 	<ul style="list-style-type: none"> ● Problems with reproducibility ● Generally not transferable 	Penner (1996), Welsh & McClelland (1990), Williams et al. (1990)
Simple sequence repeats (SSRs)* or 'microsatellites'	C	<ul style="list-style-type: none"> ● Technically simple ● Robust and reliable ● Transferable between populations 	<ul style="list-style-type: none"> ● Large amounts of time and labour required for production of primers ● Usually require polyacrylamide electrophoresis 	McCouch et al. (1997), Powell et al. (1996), Taramino & Tingey (1996)
Amplified fragment Length Polymorphism (AFLP)	D	<ul style="list-style-type: none"> ● Multiple loci ● High levels of polymorphism generated 	<ul style="list-style-type: none"> ● Large amounts of DNA required ● Complicated methodology 	Vos et al. (1995)

*SSRs are also known as sequence tagged microsatellite site (STMS) markers (Davierwala et al., 2000; Huettel et al., 1999; Mohapatra et al., 2003; Winter et al., 1999).

Applications of molecular markers in plant science

Molecular markers have been looked upon as tools for a large number of applications ranging from localization of a gene to improvement of plant varieties by marker-assisted selection. They have also become extremely popular markers for phylogenetic analysis adding new dimensions to the evolutionary theories. If we look at the history of the development of these markers, it is evident that they have been improved over the last two decades to provide easy, fast and automated assistance to scientists and breeders. Genome analysis based on molecular markers has generated a vast amount of information and a number of databases are being generated to preserve and popularize it.

Mapping and tagging of genes: Generating tools for marker-assisted selection in plant breeding

Plant improvement, either by natural selection or through the efforts of breeders, has always relied upon creating, evaluating and selecting the right combination of alleles. The manipulation of a large number of genes is often required for improvement of even the simplest of characteristics. With the use of molecular markers it is now a routine to trace valuable alleles in a segregating population and mapping them. These markers once mapped enable dissection of the complex traits into component genetic units more precisely, thus providing breeders with new tools to manage these complex units more efficiently in a breeding programme.

The very first genome map in plants was reported in maize, followed by rice, *Arabidopsis* etc. using RFLP markers. Maps have since then been constructed for several other crops like potato, barley, banana, members of Brassicaceae, etc. Once the framework maps are generated, a large number of markers derived from various techniques are used to saturate the maps as much as is possible. Microsatellite markers, especially STMS markers, have been found to be extremely useful in this regard. Owing to their quality of following clear Mendelian inheritance, they can be easily used in the construction of index maps, which can provide an anchor or reference point for specific regions of the genome. About 30 microsatellites have already been assigned to five linkage groups in *Arabidopsis*, while their integration into the genetic linkage maps is still in progress in rice, soybean, maize, etc. The very first attempt to map microsatellites in plants was made by Zhao and Kochert in rice using (GGC)*n*, followed by mapping of (GA)*n* and (GT)*n* by Tanksley *et al.* and (GA/AG)*n*, (ATC) 10 and (ATT) 14, by Panaud *et al.* in rice. The most recent microsatellite map has

been generated by Milbourne *et al.* for potato. Similar to microsatellites, looking at the pattern of variation, generated by retrotransposons, it is now proposed that apart from genetic variability, these markers are ideal for integrating genetic maps.

Once mapped, these markers are efficiently employed in tagging several individual traits that are extremely important for a breeding programme like yield, disease resistance, stress tolerance, seed quality, etc. A large number of monogenic and polygenic loci for various traits have been identified in a number of plants, which are currently being exploited by breeders and molecular biologists together, so as to make the dream of marker-assisted selection come true. Tagging of useful genes like the ones responsible for conferring resistance to plant pathogen, synthesis of plant hormones, drought tolerance and a variety of other important developmental pathway genes, is a major target. Such tagged genes can also be used for detecting the presence of useful genes in the new genotypes generated in a hybrid programme or by other methods like transformation, etc. RFLP markers have proved their importance as markers for gene tagging and are very useful in locating and manipulating quantitative trait loci (QTL) in a number of crops. The very first reports on gene tagging were from tomato, availing the means for identification of markers linked to genes involved in several traits like water use efficiency, resistance to *Fusarium oxysporum* (the 12 gene), leaf rust resistance genes LR 9 and 24 (refs 78, 79), and root knot nematodes (*Meloidogyne* sp.) (the mi gene). Recently, Xiao *et al.* have shown the utility of RFLP markers in identifying the trait improving QTL alleles from wild rice relative *O. rufipogon*.

Allele-specific associated primers have also exhibited their utility in genotyping of allelic variants of loci that result from both size differences and point mutations. Some of the genuine examples of this are the waxy gene locus in maize, the Glu D1 complex locus associated with bread making quality in wheat, the *Lr1* leaf rust resistance locus in wheat, the Gro1 and H1 alleles conferring resistance to the root cyst nematode *Globodera rostochiensis* in potato, and allele-specific amplification of polymorphic sites for detection of powdery mildew resistance loci in cereals. A number of other traits have been tagged using ASAPs in tomato, lettuce, etc. Besides ASAPs, AFLP and SSR markers have been identified to be associated with quantitative resistance to *Globodera pallida* (stone) in tetraploid potato, which can be very well employed in marker-assisted selection.

STMS markers have displayed a potential use as diagnostic markers for important traits in plant breeding programmes, e.g. (AT) 15 repeat has been located within a soybean heat shock protein gene which is about 0.5 cM from (Rsv) a gene conferring resistance to soybean mosaic virus. Several resistance genes including peanut mottle virus (Rpv), phytophthora (Rps3) and Javanese rootknot nematode are clustered in this region of the soybean genome.

Similar to specific markers like RFLPs, STMS and ASAPs, arbitrary markers like RAPDs have also played important role in saturation of the genetic linkage maps and gene tagging. Their use in mapping has been especially important in systems, where RFLPs have failed to reveal much polymorphism that is so very important for mapping. One of the first uses of RAPD markers in saturation of genetic maps was reported by Williams *et al.* They have proven utility in construction of linkage maps among species where there has been inherent difficulty in producing F₂ segregating populations and have large genome size, e.g. conifers. RAPD markers in near isogenic lines can be converted into SCARs and used as diagnostic markers. SCAR/STS marker linked to the translocated segment on 4 AL of bread wheat carrying the *Lr28* gene has been tagged by Naik *et al.* Recently, ISSRs, which too belong to the arbitrary marker category, but are found to be devoid of many of the drawbacks shared by RAPD class of markers, have been employed as a reliable tool for gene tagging. An ISSR marker (AG) 8YC has been found to be linked closely (3.7 ± 1.1 cM) to the rice nuclear restorer gene, RF1 for fertility. RF1 is essential for hybrid rice production and this marker would be useful not only for breeding both restorer and maintainer lines, but also for the purity management of hybrid rice seeds. Similarly ISSR marker (AC)₈ YT has been found to be linked to the gene for resistance to *Fusarium* wilt race 4 in repulsion at a distance of 5.2 cM in chickpea.

Apart from mapping and tagging of genes, an important utility of RFLP markers has been observed in detecting gene introgression in a backcross breeding programme, and synteny mapping among closely related species. Similar utility of STMS markers has been observed for reliable pre selection in a marker assisted selection backcross scheme. Apart from specific markers, DAMD-based DNA fingerprinting in wheat has also been useful for monitoring backcross-mediated genome introgression in hexaploid wheat.

Phylogeny and evolution

Most of the early theories of evolution were based on morphological and geographical variations between organisms. However, it is becoming more and more evident that the techniques from molecular biology hold a promise of providing detailed information about the genetic structure of natural population, than what we have been able to achieve in the past. RFLP, DNA sequencing, and a number of PCR-based markers are being used extensively for reconstructing phylogenies of various species. The techniques are speculated to provide path-breaking information regarding the fine time scale on which closely related species have diverged and what sort of genetic variations are associated with species formation. Furthermore, these studies hold a great promise for revealing more about the pattern of genetic variation within species.

Efforts are now being made for studying the genetic variation in plants, so as to understand their evolution from wild progenitors and to classify them into appropriate groups. The taxonomic classification is an essential first step to determine whether any germplasm is a part of the primary, secondary or tertiary gene pool of the system concerned. This is especially important in cases where morphological markers can prove to be inaccurate and misleading. A genuine example of this is the lines Azucena and PR 304 which have been classified as *indicas* using morphological characters, whereas they behave like *japonicas* in crossing studies. These samples are however, clearly revealed to be *japonicas* upon being analysed by RAPD markers.

RFLPs have been used in evolutionary studies for deducing the relationship between the hexaploid genome of bread wheat and its ancestors. Similarly a number of transposon elements like *tos1-1*, *tos2-1* and *tos3-1* retrotransposons have been used to detect the genetic differences between different species of rice and even between ecotypes of cultivated rice, wherein they were found to distinguish between the cultivars of Asian and African rice, *O. sativa* and *O. glaberrima*. Retroelement *Wis-2* has been found to detect genomic variation within individual plants of wheat variety and also within and between varieties of wheat. This element has also been found to occur in the genomes of other grasses like barley, rye, oats and *Aegilops* species, indicating common ancestral elements in grasses. Though RFLPs, microsatellites, minisatellites and transposons are useful for carrying out genetic variability analysis, the trend is now shifting towards the use of PCR-based markers. Specific markers are preferred over arbitrary primers. However, arbitrary primers are found to be the markers of choice in the analysis of complex genomes like

wheat, where genetic variation is extremely difficult to dissect. Sen *et al.* have used DAF as a new source of molecular markers in fingerprinting of bread wheat. Recent studies in our laboratory have revealed the utility of RAPD and ISSR markers in evolutionary studies of wheat and rice, respectively.

Specific markers like STMS (sequence-tagged microsatellite markers) ALPs (Amplicon length polymorphisms) or STS markers have proved to be extremely valuable in the analysis of gene pool variation of crops during the process of cultivar development, and classification of germplasm. These markers are extremely sensitive and can detect allelic variability during cultivar development. STS markers specific to chloroplast or mitochondrial DNA have been useful in providing seed and pollen specific markers which can be utilized for the detection of length variation at multiple physically linked sites and may be used to provide haplotype data and thus genotypically unique individual plants. Also a comparison of patterns of variability detected with biparentally (nuclear) and uniparentally (organellar) transmitted markers can provide complementary information to population and evolutionary biologists. Excellent examples of this are the Poly A mononucleotide repeats in maize, Poly (TA/AT) dinucleotide repeats found in liverworts, maize, pea and non photosynthetic green plant *Epifagus virginiana*, and a total of 500 chloroplast SSRs identified with repeat motifs greater than 10 repeat units in rice, tobacco, black pine, liverwort and maize. Though all these marker types provide valuable information regarding the evolution and phylogeny of various species being studied in any given set of samples, the trend is now shifting towards the use of ESTs (expressed sequence tags) for such analysis. This may be so, because in such studies, one actually looks at the evolution of functional genes.

Diversity analysis of exotic germplasm

Following domestication, genetic variation in crop plants has continued to narrow due to continuous selection pressure for specific traits i.e. yield, thus rendering them more vulnerable to disease and insect epidemics and jeopardizing the potential for sustained genetic improvement over a long term. This risk was brought sharply into focus in 1970 with the outbreak of southern corn leaf blight which drastically reduced corn yield in USA, and was attributed to extensive use of a single genetic male sterility factor which was unfortunately linked to the disease susceptibility. Thus it is extremely important to study the genetic composition of the germplasm of existing modern-day cultivars in comparison with their ancestors and related species. This will not only provide information on their phylogenetic relationship but will also indicate a chance of finding new and useful genes, as

the accessions with most distinct DNA profiles are likely to contain a greater number of novel alleles. DNA profiling to make such sampling decisions is now underway in most crops. The exotic germplasm for breeding is selected on the basis of certain characteristic features such as (a) the exotic germplasm must possess a significant number of unique DNA polymorphisms (throughout the genome) relative to the modern-day cultivars and (b) each exotic germplasm has to be genetically dissimilar (on the basis of DNA profiling). This is necessary to understand the genetic variations between the existing cultivars, the cultivars in comparison with their wild progenitors and a number of wilds that still exist in nature.

Many DNA markers both specific as well as arbitrary have been used so far, for DNA fingerprinting of various classes of germplasm. Further studies with STMS markers may also throw light on the domestication process involved in crop plants and provide useful criteria for enriching the gene pool of crop plants and determine how efficient plant breeders have been in accessing preexisting forms of variation. AFLP, a new class of molecular markers, has gained popularity as marker for the study of genetic polymorphism especially in species where polymorphism is extremely rare using other types of markers. Pakniyat *et al.* used AFLP for studying variation in wild barley with reference to salt tolerance and associated eco geography, and a number of reports are coming up each day for different systems. Similarly the potential of ISSR markers has been exploited for diversity analysis of pine, rice and also in wheat. These studies have helped in the classification of existing biodiversity among plants, which can be further exploited in wild gene introgression programs.

Genotyping of cultivars

The repetitive and arbitrary DNA markers are markers of choice in genotyping of cultivars. Microsatellites like (CT)₁₀, (GAA)₅, (AAGG)₄, (AAT)₆ (ref. 123), (GATA)₄, (CAC)₅ and minisatellites have been employed in DNA fingerprinting for the detection of genetic variation, cultivar identification and genotyping. This information is useful for quantification of genetic diversity, characterization of accessions in plant germplasm collections and taxonomic studies. Microsatellites have been useful for generation of STMS markers, revealing polymorphisms within closely related cultivars. The first application of microsatellites in plants has been in cultivar identification, wherein microsatellites have been used to genotype unequivocally diverse materials like rice, wheat, grapevine, soybean, etc. This is important especially for protection of proprietary germplasm. Similarly

microsatellite markers have also been advantageous in pedigree analysis as they represent single locus. The multi allelism of these markers facilitates comparative allelic variability detection reliably across a wide range of germplasm and allows individuals to be ubiquitously genotyped, so that gene flow and paternity can be established.

One of the most recent applications of these markers has been shown in sex identification of dioecious plants, wherein microsatellite probe (GATA)₄ is found to reveal sex-specific differences in Southern analysis and can be used as a diagnostic marker in this system where male and female plants do not show any sex-specific morphological difference until flowering. Similarly, Di Stilio *et al.* have identified a randomly-amplified (RAPD) DNA marker for pseudo-autosomal plant sex chromosome in *Silene dioica* (L.).

Indian scenario for development of molecular markers in crop improvement programmes

Agriculture is one of the most important occupations in India with almost 70% of the population being dependent on it. A noteworthy research in conventional breeding for several years has made this country self-sufficient in many respects. However, the ever-increasing population has alarmed food security in India and attempts have been initiated to integrate modern biotechnology tools in conventional breeding to improve the most important crops such as rice, wheat and legumes.

Extensive research using DNA markers is in progress in many institutions all over India. Markers tagged and mapped with specific genes have been identified and some such examples include resistance genes for blast and gall midge using RFLP- and PCR-based approaches in rice. Similarly, in wheat, leaf rust resistance gene *LR 28*, and pre-harvest sprout tolerance gene have been tagged. QTLs such as protein content in wheat and heterosis in rice have also been identified. While efforts for tagging genes providing resistance to BPH, WBPH, sheath rot and drought are going on, many attempts are also being made towards pyramiding different resistance genes for a specific disease or pest attack like blast, bacterial blight, gall midge, BPH, WBPH, etc. in rice in order to increase the field life of the crop.

Germplasm analysis to study genetic diversity is another important area in which a lot of efforts have been put in. Fingerprinting of crops like rice, wheat, chickpea, pigeonpea, pearl

millet etc. is being carried out extensively. This information has potential in strategic planning of future breeding towards crop sustainability in India. Apart from use of molecular markers in crop plants, efforts are also underway in other horticultural plants. Early identification of sex in dioecious papaya using molecular marker is one such example.

Thus in the last few years there are many reports of amalgamation of classical breeding and modern biotechnological approaches which have unlimited scope in Indian agriculture.

Questions

- DNA-based molecular markers are widely used in
 - taxonomy
 - embryology
 - genetic engineering
 - d). All the above**
- The term DNA-fingerprinting was introduced for the first time by
 - a). Alec Jeffrey**
 - Botstein
 -
 - None of the above
- The properties desirable for ideal DNA markers are
 - Highly polymorphic nature
 - Codominant inheritance
 - Frequent occurrence in genome
 - d). All the above**
- The properties desirable for ideal DNA markers are
 - Selective neutral behaviour
 - Easy access
 - Easy and fast assay
 - d). All the above**
- The properties desirable for ideal DNA markers are
 - High reproducibility
 - Easy exchange of data between laboratories
 - Easy and fast assay
 - d). All the above**
- The single or low copy probes include
 - RFLP
 - EST
 - RLGS
 - d). All the above**
- RFLP markers were used for the first time in the construction of genetic maps by
 - Alec Jeffrey
 - b). Botstein**
 - Hatada
 - None of the above
- RLGS markers were used for the first time in the construction of genetic maps by
 - Alec Jeffrey
 - Botstein
 - c). Hatada**
 - None of the above

9. EST markers were used for the first time by

- a). Alec Jeffrey
- b). Botstein
- c). Hatada
- d). Adams**

10. The multi locus probes include

- a). Microsatellites and minisatellites
- b). STMS
- c). ISSR
- d). All the above**

11. The term microsatellite was coined by

- a). Litt
- b). Luty
- c). Both a and b**
- d). None of the above

12. The term minisatellite was coined by

- a). Litt
- b). Luty
- c). Jeffrey**
- d). None of the above

13. RAPD was developed by.....

- a). Welsh and McClelland**
- b). Litt and Luty
- c). Jeffrey
- d). None of the above

QTL mapping

Quantitative traits

Many traits of agronomic and horticultural interest are controlled by a single gene and fall into a few distinct phenotypic classes. These classes can be used to predict the genotypes of the individuals. For example, if we cross a tall and short pea plant and look at F2 plants, we know the genotype of short plants, and we can give a generalized genotype for the tall plant phenotype. Furthermore, if we know the genotype we could predict the phenotype of the plant. These types of phenotypes are called **discontinuous traits**.

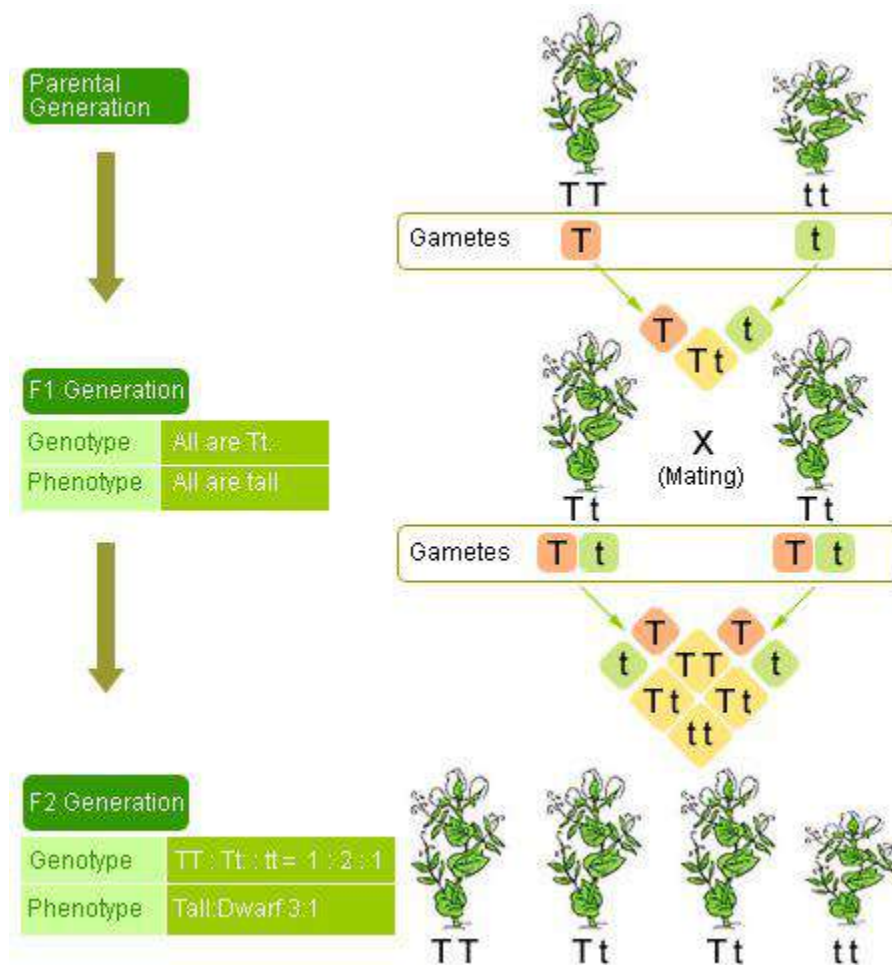

Other traits do not fall into discrete classes. Rather, when a segregating population is analyzed for these traits, a continuous distribution is found. An example is ear length in corn. Black Mexican Sweet corn has short ears, whereas Tom Thumb popcorn has long ears. When these

two inbred lines are crossed, the length of the F1 ears is intermediate to the two parents. Also, the length does not fall into a tight distribution, but exhibits a bell-shaped distribution.

Furthermore, when the F1 plants are intermated, the distribution of ear length in the F2 ranges from the short ear Black Mexican Sweet size to the Tom Thumb popcorn size with a distribution that resembles the bell-shaped curve for a normal distribution. These types of traits are called continuous traits and cannot be analyzed in the same manner as discontinuous traits. Because continuous traits are often given a quantitative value, they are often referred to as quantitative traits, and the area of genetics that studies their mode of inheritance is called quantitative genetics. Furthermore, the loci controlling these traits are called quantitative trait loci or QTL.

Because many important agricultural traits such as crop yield are quantitative traits, much of the pioneering research into the modes of inheritance of these traits was performed by agricultural geneticists. These traits are controlled by multiple genes, each segregating according to Mendel's laws. These traits can also be affected by the environment to varying degrees.

QTL mapping

Quantitative characters have been a major area of studying in genetics for over a century, as they are common feature of natural variation in populations of all eukaryotes, including crop plants. For most of the period up to 1980, the study of quantitative traits has involved statistical techniques based on means, variances and covariances of relatives. These studies provided a conceptual base for partitioning the total phenotypic variance into genetic and environmental variances and further analyzing the genetic variance in terms of additive, dominance and epistatic effects. From this information, it became feasible to estimate the heritability of the trait and predict the response of the trait to selection. It was also possible to estimate the minimum number of genes that controlled the trait of interest. However, little was known about what these genes were, where they are located, and how they controlled the traits, apart from the fact that for any given trait, there were several such genes segregating in a Mendelian fashion in any given population, and in most cases their effects were approximately additive. These genes were termed polygenes. Sax's experiment with beans demonstrated that the effect of an individual locus affecting a quantitative trait could be isolated through a series of crosses resulting in randomization of the genetic background with respect to all genes not linked to the genetic markers under observation. Even though all of the markers used by Sax were morphological seed markers with complete dominance, he was able to show a significant effect

on seed weight associated with some of his markers. Despite this demonstration, there were extremely few successful detections of marker-QTL linkage in crop plants during 1930-80s and of these even fewer were reported. The major limitation was the lack of availability of adequate polymorphic markers.

Two major developments during the 1980s changed the scenario: (i) the discovery of extensive, yet easily visualized, variability at the DNA level that could be used as markers; and (ii) development of statistical packages that can help in analyzing variation in a quantitative trait in congruence with molecular marker data generated in a segregating population. With phenomenal improvements in molecular marker technology in the last two decades, identification and utilization of polymorphic DNA markers as a framework around which the polygenes could be located, has improved multiple-fold. It is now clear that a genetic map saturated with polymorphic codominant Mendelian markers can be generated for almost any species. Nearly saturated genetic maps have already been produced for most species of economic or scientific interest. We now refer the polygenes as “QTL” (Quantitative Trait Loci), a term first coined by Gelderman. A QTL is defined as “ a region of the genome that is associated with an effect on a quantitative trait”. Conceptually, a QTL can be a single gene, or it may be a cluster of linked genes that affect the trait.

Principle of QTL mapping

It is not difficult in populations of most crop plants to identify and map a good number of segregating markers (10 to 50) per chromosome. However, most of these markers would be in non coding regions of the genome and might not affect the trait interest directly; but a few of these markers might be linked to genomic regions (QTLs) that do influence the trait of interest. Where such linkages occur, the marker locus and the QTL will cosegregate. Therefore, the basic principle of determining whether a QTL is linked to a marker is to partition the mapping population into different genotypic classes based on genotypes at the marker locus, and then apply correlative statistics to determine whether the individuals of one genotype differ significantly with the individuals of other genotype with respect to the trait being measured. Situations where genes fail to segregate independently are said to display “linkage disequilibrium”. QTL analysis thus depends on linkage disequilibrium.

With natural populations, consistent association between QTL and marker genotype will not usually exist, except in a very rare situation where the marker is completely linked to the QTL.

Therefore, QTL analysis is usually undertaken in segregating mapping populations, such as F2 derived populations, recombinant inbred lines (RILs), near-isogenic lines (NILs), double haploid lines (DHs) and backcross populations.

Objectives of QTL mapping

1. To identify the regions of the genome that affect the trait of interest
2. To analyze the effect of the QTL on the trait
 - a. How much of the variation for the trait is caused by a specific region?
 - b. What is the gene action associated with the QTL (additive effect? Dominant effect?)
 - c. Which allele is associated with the favourable affect?

Salient requirements for QTL mapping

- A suitable mapping population generated from phenotypically contrasting parents.
- A saturated linkage map based on molecular markers
- Reliable phenotypic screening of mapping population
- Appropriate statistical package to analyze the genotypic information in combination with phenotypic information for QTL detection.

Types and size of mapping population

Random mating populations are more difficult for QTL mapping, because linkage disequilibrium is a key to detecting QTLs with markers. It is essential to develop a suitable experimental mapping population using parental lines that are highly contrasting phenotypically for the target trait (ex., highly resistant and susceptible lines). Another important requirement is that these parental lines should be genetically divergent; this is important to enhance the possibility of identifying a large set of polymorphic markers that are well distributed across the genome. To fulfill the second criterion, one may have to carry out molecular polymorphism survey across a set of potentially useful lines so as to identify the most suitable ones for generation of mapping population.

The choice of a mapping population could vary based upon the objectives of the experiment, the timeframe as well as resources available for undertaking QTL analysis. But, the ability to detect QTLs or the information contained in F2 or F2 derived populations and RILs are relatively higher than others. The primary advantage of F2:3 families is the ability to measure the effects of

additive and dominance gene actions at specific loci. Because RILs are essentially homozygous, only additive gene action can be measured. The advantage, though, of the RILs is the ability to perform larger experiments at several locations and even in multiple years. For many crops, it is not possible to generate enough seed to perform a multi-location experiment with population of F2:3 families. Modification of the genetic model is necessary to accommodate different types of populations.

The size of the mapping population for QTL analysis depends on several factors, including the type of mapping population employed for analysis, genetic nature of the target trait, objectives of the experiment, and the resources available for handling a sizable mapping population in terms of phenotyping and genotyping. While analysis of a large number of individuals (500 or more) would enable detection of even QTLs having small effects on the target trait, from the practical point of view (MAS), the basic purpose of QTL mapping would be largely served if one can detect the QTLs with major effects. This would require, in general, a mapping population of a size of 200-300 individuals.

Generating a reasonably saturated linkage map

By screening the mapping population using polymorphic molecular markers (popularly called as genotyping), we can analyze the segregation patterns for each of the markers. The segregation patterns are usually in consonance with the type of mapping population used. The genotypic data is then analyzed using a statistical package such as MAPMAKER or JOINMAP, for construction of a linkage map of the molecular markers analyzed in the study. Mapping means placing the markers in order, indicating the relative genetic distances between them and assigning them to their linkage groups on the basis of recombination values from all pairwise combinations between the markers.

To perform a whole-genome QTL scan, it is desirable to have a saturated marker map. In such a map, markers are available for each chromosome from one end to the other, and adjacent markers are spaced sufficiently close that recombination events only rarely occur between them. For practical purposes, this is generally considered to be less than 10 recombinations per 100 meiosis, or a map distance of less than 10 centiMorgans (cM). In the model plant *Arabidopsis thaliana*, which has a particularly small genome, this requires as few as 50 markers. Several-fold more markers are needed for plant genomes such as wheat and maize. In crops

like maize, a broad 'rule-of-the-thumb' is to cover each of the chromosomal (bin) locations with at least one or two polymorphic molecular markers.

Phenotyping of mapping population and sample size

The target quantitative traits have to be measured as precisely as possible and limited amounts of missing data can be tolerated. The power to resolve the QTL location is limited first by sample size and then by genetic marker coverage of the genome. Often, the number of individuals in a sample might appear to be large but missing data or skewed allele frequencies in the population cause the effective sample size to diminish, thus sacrificing statistical power. Sometimes, it may be necessary to sacrifice population size in favour of data quality and this trade off means that only major QTL (with relatively large effect) can be detected. Data is typically pooled over locations and replications to obtain a single quantitative trait for the line. It is also preferable to measure the target trait(s) in experiments conducted in multiple (and appropriate) locations to have a better understanding of the QTL x environment interaction, if any.

Factors affecting the power of QTL mapping

QTLs are statistically inferred from the data generated in an experiment. However, statistical influence does not always indicate biological significance due to multiple test problems associated with QTL mapping. The following factors affect the power of QTL mapping:

- Number of genes controlling the target trait(s) and their genome positions
- Distribution of genetic effects and existence of genetic interactions
- Heritability of the trait
- Number of genes segregating in a mapping population
- Type and size of mapping population
- Density and coverage of markers in the linkage map
- Statistical methodology employed and significance level used for QTL mapping.

Replicate progeny analysis, selective genotyping, sample pooling and sequential sampling are some of the suggested approaches for optimization of experimental designs, so as to enhance the power of QTL detection and estimation of QTL effects.

Mapping QTL with Molecular Markers

The improvement of quantitative traits has been an important goal for many plant breeding programs. With a pedigree breeding program, the breeder will cross two parents and practice

selection until advanced-generation lines with the best phenotype for the quantitative trait under selection are identified. These lines will then be entered into a series of replicated trials to further evaluate the material with the goal of releasing the best lines as a cultivar. It is assumed that those lines which performed best in these trials have a combination of alleles most favorable for the fullest expression of the trait.

This type of program, though, requires a large input of labor, land, and money. Therefore plant breeders are interested in identifying the most promising lines as early as possible in the selection process. Another way to state this point is that the breeder would like to identify as early as possible those lines which contain those QTL alleles that contribute to a high value of the trait under selection. Plant breeders and molecular geneticists have joined efforts to develop the theory and technique for the application of molecular genetics to the identification of QTLs.

Molecular markers associated with QTLs are identified by first scoring members of a random segregating population for a quantitative trait. The molecular genotype (homozygous Parent A, heterozygous, or homozygous parent B) of each member of the population is then determined. The next step is to determine if an association exists between any of the markers and the quantitative trait.

The most common method of determining the association is by analyzing phenotypic and genotypic data by one-way analysis of variance and regression analysis. For each marker, each of the genotypes is considered a class, and all of the members of the population with that genotype are considered an observation for that class. (Data is typically pooled over locations and replications to obtain a single quantitative trait value for the line.) If the variance for the genotype class is significant, then the molecular marker used to define the genotype class is considered to be associated with a QTL. For those loci that are significant, the quantitative trait values are regressed onto the genotype. The R^2 value for the line is considered to be the amount of total genetic variation that is explained by the specific molecular marker. The final step is to take those molecular marker loci that are associated the quantitative trait and perform a multiple regression analysis. From this analysis, you will obtain an R^2 value which gives the percentage of the total genetic variance explained by all of the markers.

The two types of populations that have been used to identify markers linked to QTLs are $F_2 \times 3$ families (or F_3 families from F_2 plants) and recombinant inbred lines. Each population type has

advantages and disadvantages. The primary advantage of F₂*3 families is the ability to measure the effects of additive and dominance gene actions at specific loci. Because RI lines are essentially homozygous, only additive gene action can be measured. The advantage, though, of the RI lines is the ability to perform larger experiments at several locations and even in multiple years. For many crops, it is not possible to generate enough seed to perform a multi-location experiment with population of F₂*3 families.

Application of molecular markers to selection

Once markers have been detected that are associated with QTLs, the logical next step is to perform selection on lines within a population. The obvious method would be to only advance those lines which contain those alleles with a positive effect on the quantitative trait. This type of experiment has not been performed yet, but analogous experiments may give us an indication of what we might expect from such selection experiments.

Stuber et al. developed a high-yielding maize population by selecting over ten cycles for increased yield. They next determined the allelic frequencies for eight isozyme loci that had been shown to be associated with yield. These frequencies gave them a base-line from which a new population could be constructed. The new population had essentially the same allelic frequencies as the high yielding population developed by selection. Next the yield and ears/plant were measured in the base population, the high-yielding population developed via selection, and the population constructed based on isozyme frequencies. Data from this replicated experiment grown in several locations suggested that the gain realized by simply pooling on allelic frequencies of the high-yield population was equal to two cycles of selection for yield and one and a half cycles of selection for ears/plant. These results suggest that modest gains may be realized by simply selecting based on the molecular marker genotype.

Marker assisted selection and Crop improvement

Marker assisted selection or marker aided selection (MAS) is a process whereby a marker (morphological, biochemical or one based on DNA/RNA variation) is used for indirect selection of a genetic determinant or determinants of a trait of interest (i.e. productivity, disease resistance, abiotic stress tolerance, and/or quality). This process is used in plant and animal breeding.

Considerable developments in biotechnology have led plant breeders to develop more efficient selection systems to replace traditional phenotypic-pedigree-based selection systems.

Marker assisted selection (MAS) is **indirect selection process** where a trait of interest is selected not based on the trait itself but on a marker linked to it. For example if MAS is being used to select individuals with a disease, the level of disease is not quantified but rather a marker allele which is linked with disease is used to determine disease presence. The assumption is that linked allele associates with the gene and/or quantitative trait locus (QTL) of interest. MAS can be useful for traits that are difficult to measure, exhibit low heritability, and/or are expressed late in development.

Marker types

A marker may be:

- **Morphological** - First markers loci available that have obvious impact on morphology of plant. Genes that affect form, colouration, male sterility or resistance among others have been analyzed in many plant species. Examples of this type of marker may include the presence or absence of awn, leaf sheath colouration, height, grain colour, aroma of rice etc. In well-characterized crops like maize, tomato, pea, barley or wheat, tens or even hundreds of such genes have been assigned to different chromosomes.
- **Biochemical**- A gene that encodes a protein that can be extracted and observed; for example, isozymes and storage proteins.
- **Cytological** - The chromosomal banding produced by different stains; for example, G banding.

- **Biological-** Different pathogen races or insect biotypes based on host pathogen or host parasite interaction can be used as a marker since the genetic constitution of an organism can affect its susceptibility to pathogens or parasites.
- **DNA-based and/or molecular-** A unique (DNA sequence), occurring in proximity to the gene or locus of interest, can be identified by a range of molecular techniques such as RFLPs, RAPDs, AFLP, DAF, SCARs, microsatellites etc.

Sax in 1923 first reported association of a simply inherited genetic marker with a quantitative trait in plants when he observed segregation of seed size associated with segregation for a seed coat colour marker in beans (*Phaseolus vulgaris* L.). Rasmusson in 1935 demonstrated linkage of flowering time (a quantitative trait) in peas with a simply inherited gene for flower colour.

Gene vs marker

The gene of interest is directly related with production of protein(s) that produce certain phenotypes whereas markers should not influence the trait of interest but are genetically linked (and so go together during segregation of gametes due to the concomitant reduction in homologous recombination between the marker and gene of interest). In many traits genes are discovered and can be directly assayed for their presence with a high level of confidence. However, if a gene is not isolated marker's help is taken to tag a gene of interest. In such case there may be some false positive results due to recombination between marker of interest and gene (or QTL). A perfect marker would elicit no false positive results.

Important properties of ideal markers for MAS

An ideal marker:

- Easy recognition of all possible phenotypes (homo and heterozygotes) from all different alleles
- Demonstrates measurable differences in expression between trait types and/or gene of interest alleles, early in the development of the organism
- Has no effect on the trait of interest that varies depending on the allele at the marker loci
- Low or null interaction among the markers allowing the use of many at the same time in a segregating population

- Abundant in number
- Polymorphic

Demerits of morphological markers

Morphological markers are associated with several general deficits that reduce their usefulness including:

- the delay of marker expression until late into the development of the organism
- dominance
- deleterious effects
- pleiotropy
- confounding effects of genes unrelated to the gene or trait of interest but which also affect the morphological marker (epistasis)
- rare polymorphism
- frequent confounding effects of environmental factors which affect the morphological characteristics of the organism

To avoid problems specific to morphological markers, the DNA-based markers have been developed. They are highly polymorphic, simple inheritance (often codominant), abundantly occur throughout the genome, easy and fast to detect, minimum pleiotropic effect and detection is not dependent on the developmental stage of the organism. Numerous markers have been mapped to different chromosomes in several crops including rice, wheat, maize, soybean and several others. Those markers have been used in diversity analysis, parentage detection, DNA fingerprinting, and prediction of hybrid performance. Molecular markers are useful in indirect selection processes, enabling manual selection of individuals for further propagation.

Selection for major genes linked to markers

The major genes which are responsible for economically important characteristics are frequent in the Plant Kingdom. Such characteristics include disease resistance, male sterility, self-incompatibility; others related to shape, colour, and architecture of whole plants and are often of mono- or oligogenic in nature. The marker loci which are tightly linked to major genes can be used for selection and are sometimes more efficient than direct selection for the target gene. Such advantages in efficiency may be due for example, to higher expression of the marker mRNA in such cases that the marker is actually a gene. Alternatively, in such cases that the target gene of interest differs between two alleles by a

difficult-to-detect single nucleotide polymorphism, an external marker (be it another gene or a polymorphism that is easier to detect, such as a short tandem repeat) may present as the most realistic option.

Situations that are favorable for molecular marker selection

There are several indications for the use of molecular markers in the selection of a genetic trait.

In such situations that:

- the selected character is expressed late in plant development, like fruit and flower features or adult characters with a juvenile period (so that it is not necessary to wait for the organism to become fully developed before arrangements can be made for propagation)
- the expression of the target gene is recessive (so that individuals which are heterozygous positive for the recessive allele can be crossed to produce some homozygous offspring with the desired trait)
- there is requirement for the presence of special conditions in order to invoke expression of the target gene(s), as in the case of breeding for disease and pest resistance (where inoculation with the disease or subjection to pests would otherwise be required). This advantage derives from the errors due to unreliable inoculation methods and the fact that field inoculation with the pathogen is not allowed in many areas for safety reasons. Moreover, problems in the recognition of the environmentally unstable genes can be eluded.
- the phenotype is affected by two or more unlinked genes (epistasis). For example, selection for multiple genes which provide resistance against diseases or insect pests for gene pyramiding.

The cost of genotyping (an example of a molecular marker assay) is reducing while the cost of phenotyping is increasing particularly in developed countries thus increasing the attractiveness of MAS as the development of the technology continues.

Steps for MAS

Generally the first step is to map the gene or quantitative trait locus (QTL) of interest first by using different techniques and then use this information for marker assisted selection. Generally, the markers to be used should be close to gene of interest (<5 recombination unit or cM) in order to ensure that only minor fraction of the selected individuals will be

recombinants. Generally, not only a single marker but rather two markers are used in order to reduce the chances of an error due to homologous recombination. For example, if two flanking markers are used at same time with an interval between them of approximately 20cM, there is higher probability (99%) for recovery of the target gene.

QTL mapping techniques

In plants QTL mapping is generally achieved using bi-parental cross populations; a cross between two parents which have a contrasting phenotype for the trait of interest are developed. Commonly used populations are recombinant inbred lines (RILs), doubled haploids (DH), back cross and F₂. Linkage between the phenotype and markers which have already been mapped is tested in these populations in order to determine the position of the QTL. Such techniques are based on linkage and are therefore referred to as "linkage mapping".

Single step MAS and QTL mapping

In contrast to two-step QTL mapping and MAS, a single-step method for breeding typical plant populations has been developed.^[5] In such an approach, in the first few breeding cycles, markers linked to the trait of interest are identified by QTL mapping and later the same information is used in the same population. In this approach, pedigree structures are created from families that are created by crossing number of parents (in three-way or four way crosses). Both phenotyping and genotyping is done using molecular markers mapped the possible location of QTL of interest. This will identify markers and their favorable alleles. Once these favorable marker alleles are identified, the frequency of such alleles will be increased and response to marker assisted selection is estimated. Marker allele(s) with desirable effect will be further used in next selection cycle or other experiments.

High-throughput genotyping techniques

Recently high-throughput genotyping techniques are developed which allows marker aided screening of many genotypes. This will help breeders in shifting traditional breeding to marker aided selection. One of example of such automation is using DNA isolation robots, capillary electrophoresis and pipetting robots.

One of recent example of capillary system is Applied Biosystems 3130 Genetic Analyzer. This is the latest generation of 4-capillary electrophoresis instruments for the low to medium throughput laboratories.

Use of MAS for backcross breeding

A minimum of five or six-backcross generations are required to transfer a gene of interest from a donor (may not be adapted) to a recipient (recurrent – adapted cultivar). The recovery of the recurrent genotype can be accelerated with the use of molecular markers. If the F1 is heterozygous for the marker locus, individuals with the recurrent parent allele(s) at the marker locus in first or subsequent backcross generations will also carry a chromosome tagged by the marker.

Marker assisted gene pyramiding

Gene pyramiding has been proposed and applied to enhance resistance to disease and insects by selecting for two or more than two genes at a time. For example in rice such pyramids have been developed against bacterial blight and blast. The advantage of use of markers in this case allows selecting for QTL-allele-linked markers that have same phenotypic effect.

For Helping Agriculture Students

Free Study Material, Test Series at Nominal Price, Agriculture job Information,
Agriculture News & Many More on AgriExam.Com



WWW.AgriExam.Com No.1 Agriculture Study Website

Follow AgriExam on Social Media

WhatsApp No. +91-7067289494

<https://www.agriexam.com/join-us>

